

The ENEA logo is rendered in a bold, white, sans-serif font. The letters are slightly spaced out, and the 'E' and 'A' have a distinctive shape with a horizontal bar that is not fully connected to the vertical stem.

ITALIAN NATIONAL AGENCY FOR NEW TECHNOLOGIES,
ENERGY AND THE ENVIRONMENT

Editors:

Sergio MARTELLUCCI, Angela ROSATI,
Francesco SCARAMUZZI, Vittorio VIOLANTE

COLD FUSION

THE HISTORY OF RESEARCH IN ITALY

FOCUS

2008

TECHNOLOGIES

COLD FUSION

The history of research in Italy

Editors:

Sergio Martellucci, Angela Rosati, Francesco Scaramuzzi, Vittorio Violante

Translation by: Chiara Maria Costigliola

2009 ENEA
Italian National Agency for New Technologies,
Energy and the Environment

Lungotevere Thaon di Revel, 76
00196 Rome (Italy)

ISBN 978-88-8286-204-6

The Editors of the volume have not altered the authors' contributions except to conform them to the volume's graphic design and insert them into Chapters. Any possible integration and/or clarification generally appearing as footnotes has been agreed upon with each respective author. For such reason, authors are the only responsible for their works' content



COLD FUSION

The history of research in Italy

Editors:

SERGIO MARTELLUCCI, ANGELA ROSATI,
FRANCESCO SCARAMUZZI, VITTORIO VIOLANTE

EDITORIAL

The present volume represents the historical development of the research carried on in Italy in the field of the so-called "Cold Fusion" during the last twenty years.

This 2009 year marks the 20th anniversary of the announcement of the results of an experiment conducted in the University of Utah, USA, by Martin Fleishmann and Stanley Pons¹. To commemorate the "birth" of Cold Fusion, the International Advisory Committee of ICCF-14, the Conference held last August in Washington D.C., USA has decided to hold the 2009 ICCF-15 Conference in Italy. It will take place in Rome at the Angelicum University, on October 5-9, under the Chairmanship of one of us (V.V.).

The name chosen for the Conference by the Cold Fusion community has been the "15th International Conference on Condensed Matter Nuclear Science" in order to consider all the different nuclear events that take place in Condensed Matter (<http://iccf15.frascati.enea.it>).

The publication of this book, to be distributed to the participants of the 2009 Rome Conference, has to be intended as the first action planned by ENEA to honour this anniversary.

The Editors

Sergio Martellucci

Chairman of the ENEA Scientific Committee

Professor of Physics, University of Rome "Tor Vergata"

Angela Rosati

Secretariat of the ENEA Scientific Committee

ENEA Headquarters, Rome

Francesco Scaramuzzi

ENEA, Frascati Research Centre (retired)

INFN National Laboratories, Frascati, Rome

Vittorio Violante

Head for Energy Production Processes in Deuterated Metals

ENEA, Frascati Research Centre

¹ FLEISCHMANN M. AND PONS S. (1989). *Electrochemically Induced Nuclear Fusion of Deuterium*, J. Electroanal. Chem., 261:301; see also Fleischmann M., Pons S. Errata (1989) J. Electroanal. Chem., 263: 97.

FOREWORD

LUIGI PAGANETTO
President of ENEA

Twenty years have passed since two electrochemists, Martin Fleishmann and Stanley Pons, announced the achievement of nuclear reactions in a metal lattice at room temperature. During these years, many national and international conferences took place and the International Conference on Cold Fusion, which is now at its 15th edition, will be held in Rome, Italy, under the chairmanship of dr. eng. Vittorio Violante. On that occasion, the volume series on Cold Fusion History in all the countries that contributed to this discipline's development from 1989 until today will be presented. Besides Italy and the United States, also China, India, Russia, France and Japan have worked intensely in this field. ENEA – in particular the President of the Agency's Scientific Committee, prof. Sergio Martellucci – has been assigned the task of editing the volume on the history of such research in Italy by collecting the accounts on the activities carried on by single groups or laboratories operating in the field. A few years after Fleishmann-Pons' announcement, the results achieved by SRI International (Menlo Park, CA, USA) and IMRA (Okkaido, Japan) showed that excess power production was a threshold phenomenon. In other words that phenomenon could not be observed without achieving a certain level of deuterium concentration in palladium cathodes. This evidence gave rise to an original study carried out at ENEA Centre in Frascati in the field of material science. Studies went on for some years, at the end of which a new process was developed based on theoretical considerations. Actually such process allowed to obtain palladium that makes achieving the concentration threshold necessary to observe the phenomenon extremely reproducible.

In the wake of this evidence a strong collaboration has been set up between the ENEA team and some U.S. institutions (SRL Energetics, NJ, and more recently Naval Research Lab, Washington D.C.).

Activities carried out in this field have highlighted the following:

- the measured energy gains were generally much superior to those ascribable to all chemical processes which can occur in an electrochemical cell like those used during experiments;
- the effect of excess power production could be observed only with deuterium and not with hydrogen;

- by using the same materials (palladium cathodes produced at ENEA), the experimental results were the same in the three laboratories, although different calorimetric instruments were used. Thus, a significant level of transferred reproducibility was obtained.

Such evidence, all headed towards the nuclear phenomenon, created conditions for the development of two research programs – one Italian, and one U.S. – by means of government funds.

The two programs carried out in close cooperation achieved better results than those set as the research goals.

However, the importance of results lies not only in the fact that reproducibility was more than satisfying and measurements carried out in different laboratories have reached a higher order of magnitude than measurement uncertainty. It also lies in the mutual result check based on the fact that only specific material lots prepared by ENEA gave evidence of excess power production in both Institutes: ENEA and SRL Energetics. In other words, two government programs – carried out in close interaction and with check of results – have proved the existence of this phenomenon in terms that are not ascribable to a chemical process.

This must be considered a starting point. The results achieved so far represent an obligation to continue on the scientific path already started with the aim of achieving a complete definition of the studied phenomenon.

In the United States a further phase of research development supported by government is envisaged. Considering the results achieved by ENEA researchers, the Agency's undertaking is to carry on research in this field, within the framework of a co-operation program with international Institutes 'par excellence'. This is the *sine qua non* of all achievements of great scientific value.

March 2009

TABLE OF CONTENTS

Preface	1
<i>Sergio Martellucci</i> Chairman, Scientific Committee – ENEA, Rome	
1. ITALIAN COLD FUSION HISTORY	
1.1 Introduction	11
1.2 Cold Fusion Research in Italy at the ICCF3 (1993)	13
<i>Francesco Scaramuzzi</i> ENEA - Frascati	
1.3 Ten Years of Cold Fusion: An Eye-witness Account	21
<i>Francesco Scaramuzzi</i> ENEA - Frascati	
2. RESEARCH IN ENEA DEPARTMENTS	
2.1 Introduction	47
2.2 Cold Fusion at ENEA Frascati from 1989 to 1998	51
<i>Francesco Scaramuzzi</i> INFN National Laboratories, Frascati	
2.3 Cold Fusion Research Carried Out at Frascati and at The “Texas A&M University” for Heat Measurement, within a collaboration context	67
<i>Aurelio La Barbera</i> ENEA - Casaccia	
2.4 Historical Reconstruction of Cold Fusion Activities at ENEA	73
<i>Antonella De Ninno and Antonio Frattolillo</i> ENEA - Frascati	
2.5 Italian Cold Fusion History and International Collaborations	87
<i>Vittorio Violante</i> ENEA - Frascati	
2.6 Gas Loading at Low Temperatures	99
<i>Francesco Scaramuzzi</i> INFN National Laboratories, Frascati	

3.	RESEARCH IN CNR LABORATORIES	
3.1	Introduction	103
3.2	Measurement of Lattice Parameters During Deuterium Charging in Palladium	105
	<i>Francesco Scaramuzzi</i>	
	INFN National Laboratories, Frascati	
3.3	A Possible Explanation of Cold Nuclear Fusion Process	107
	<i>Sergio Martellucci</i>	
	Scientific Committee – ENEA, Rome	
4.	RESEARCH AT INFN (National Laboratories and Sections)	
4.1	Introduction	109
4.2	Understanding Cold Fusion Phenomena	111
	<i>Renato Angelo Ricci, Francesco De Marco and Elio Sindoni</i>	
	INFN National Laboratories – Legnaro, Padua, ENEA – Frascati and Milan University	
4.3	The so-called “Cold Fusion” Experiments (1989-2007)	115
	<i>Francesco Celani</i>	
	INFN National Laboratories, Frascati	
4.4	Search for Neutron Emission from Titanium-Deuterium Systems	137
	<i>Corrado Boragno, Roberto Eggenhoffner, Paolo Prati, Giovanni Ricco, Mauro Taiuti and Ugo Valbusa</i>	
	Genoa University – Physics Department	
4.5	Research on the so-called “Cold Fusion” in Catania	141
	<i>Marcello Baldo, Fulvio Frisone and Augusto Scalia</i>	
	INFN - Catania/ Catania University- Physics and Astronomy Departments	
4.6	Pd Systems Loaded with D₂ and H₂ gases and Irradiated by Laser Beams	155
	<i>Antonella Lorusso and Vincenzo Nassisi</i>	
	Lecce University- Physics Department	

5.	RESEARCH IN UNIVERSITIES (Institutes, Departments and INFN Sections)	
5.1	Introduction	163
5.2	The Dialogue Between Theory of Coherence and Cold Fusion <i>Emilio Del Giudice</i> INFN - Milan	165
5.3	Anomalous effect between 200 and 400 °C on Ni-H Systems. Neither chemical nor electrochemical phenomenon <i>Sergio Focardi and Francesco Piantelli</i> I.M.O. Bologna and Siena	171
5.4	X-ray, Heat Excess and ^4He in the Pd/D System <i>Daniele Gozzi, Riccardina Caputo, Fabio Cellucci, Pierluigi Cignini, Guido Gigli, Massimo Tomellini, Salvatore Frullani, Franco Garibaldi, Evaristo Cisbani and Guido Maria Urciuoli</i> “La Sapienza” and “Tor Vergata” Universities of Rome - ISS Physics Laboratory – INFN Health Unit	183
5.5	Studying LENR at Livorno Naval Academy <i>Lino Daddi</i> Naval Academy – Physics Sector - Livorno	193
6.	RESEARCH IN INDUSTRIAL LABORATORIES	
6.1	Introduction	195
6.2	Pirelli Group Activity in the Field of Cold Fusion <i>Flavio Fontana, Luca Gamberale and Daniele Garbelli</i> Pirelli Labs SpA - Milano	197
6.3	Cold Fusion Activities at STMicroelectronics <i>Ubaldo Mastromatteo</i> STMicroelectronics - Milano	199
6.4	Cold Fusion at ORIM SpA <i>Alfredo Mancini</i> ORIM SpA - Macerata	213
7.	LIST OF CONTRIBUTING AUTHORS	215

PREFACE

SERGIO MARTELLUCCI

Chairman, Scientific Committee – ENEA, Rome

The present volume describes the Italian research history which has been stimulated by the most singular scientific discovery over the last few decades of the last century, the so-called "Cold Fusion".

On March 23, 1989, the University of Utah, USA, announced the results of an experiment conducted by two Electrochemistry Professors, Martin Fleischmann and Stanley Pons. In a table-top electrochemical cell they achieved nuclear fusion reactions between D nuclei at very low levels of energy, and the generation of unexplainable excess thermal energy with no potentially-dangerous radiation emission, which was quite unexpected. Actually its level was enormously higher than that usually ascribed to exothermic phenomena – both chemical and physical – predictable in that kind of experiment.

Such experiment was repeated with alternate success in many laboratories in all countries all over the world. Failures and lack of reproducibility in various experiments generated a widespread scepticism about this phenomenon, that quickly replaced the excessive interest immediately showed by the scientific community.

Twenty years after that very first experiment, however, research on Cold Fusion has taken remarkable steps forward – both experimental and theoretical – so that this empiric science has regained its credibility. Today it is known as LENR (Low Energy Nuclear Reactions), a sector of nuclear condensed matter physics.

By way of surveys ENEA Scientific Committee – installed by the then President Carlo Rubbia on February 8, 2005 – collected information about Cold Fusion research carried out in ENEA. Such information is summarized in paragraph 3.6 of the "Scientific Committee Report about present and future programmatic activities of ENEA", dated May 2006, and are reproduced in the introduction notes in Chapter 2, that the reader is invited to refer to.

Later in 2006, as quoted in Progress Report 2006 by the Nuclear Fusion and Fission, and Related Technologies Department, ENEA-Frascati (Rome), pages 149-151: “.... *Prestigious institutions have been working in this field and some have cooperated successfully. It was discovered (D9, D10)¹ that the phenomenon of excess power production was a threshold effect occurring only if the average deuterium concentration in the palladium lattice was not less than 0.9 (atomic fraction). Studies performed at ENEA Frascati highlighted the fact that the high loading of deuterium in the lattice was not reproducible when using commercial palladium. Hence, a wide material-science study was carried out to produce a metal with a proper metallurgical structure, capable of giving a very high deuterium concentration during electrochemical loading.*

Under contract agreements ENEA delivered cathodes prepared with such a particular palladium to SRI International (California USA) and Energetics Ltd. (US company with a research centre in Israel). A reasonable level of transferred reproducibility was achieved by the three groups and this was one of the reasons for promoting a two-phase research project with government funding in the USA to revisit the “cold fusion effect”. ENEA was involved in the programme as ENEA cathodes were selected for the research. During the first phase SRI International was charged with replicating the results obtained with ENEA’s cathodes and with the calorimeters used by Energetics Ltd. Phase 1 was concluded at the beginning of 2007 with results well above the objectives defined by the US Government referees, and continuation of the project towards Phase 2 was approved. In the second phase, the US Naval Research Laboratory is also involved in replicating the experiments.

The Italian Ministry of Economic Development (MSE) supported a two-year project (Produzione di Eccesso di Potenza in Metalli Deuterati) to improve the material science study and to gain an enhanced signal/noise ratio. Material science studies have been extended to surface physics aspects and to interphase physics, with the involvement of the University of Rome La Sapienza.

¹ D9 – M. McKubre et al., *Excess power observation in electrochemical studies of the D/Pd system; the influence of loading*, Proc. 3rd Inter. Conference on Cold Fusion (Nagoya 1992) p. 5

D10 – K. Hunimatsu et al., *Deuterium loading ratio and excess heat generation during electrolysis of heavy water by a palladium cathode in a closed cell using a partially immersed fuel cell anode*, Proc. 3rd Inter. Conference on Cold Fusion (Nagoya 1992), p. 31

The Italian project began in January 2006 and overlapped Phase 1, so the two projects have been developed in parallel. During this period both ENEA and SRI International gained reproducibility not less than 60% with a signal/noise ratio well above the measurement uncertainty...

.... The amount of energy gain and the occurrence of the effect with deuterium and not with hydrogen point in the direction of a nuclear fusion reaction between two deuterons producing, in the lattice, ^4He and heat. This is in agreement with preliminary measurements of $^4\text{He}(\text{D11-D14})^2$, which reveal an increase in the concentration above the ambient level, consistent with the energy gain.

In 2005 a very positive co-operation was started in the field of materials science with the Materials Branch of the Naval Research Institute of Washington DC. This ongoing research activity is funded by the Office of Naval Research Global (ONRG), London UK, and an important experiment has already been carried out at the Brookhaven National Laboratory, USA. X-ray diffraction was performed during electrochemical loading of cathodes prepared at ENEA in order to study the palladium hydride (deuteride) in the so far unexplored region of loading above $\text{H}(\text{D})\text{Pd} > 1$. The experiment was concluded successfully by collecting more than 240 spectra.

The support received by MSE has made it possible to extend the material science study by performing a systematic characterisation of the surface of cathodes on the basis of the atomic force microscopy (AFM) and scanning electron microscopy (SEM) analyses ...

.....The SEM and AFM analyses revealed some differences in the samples. A specific work devoted to identifying the correlation between excess of heat and the characteristics of the sample, now in progress, should lead to identification of the characteristics of the rough material capable of producing Pd cathodes with a further increasing of the reproducibility of excess power production.”

² D11 – V. Violante et al., *Some recent results at ENEA*, Proc. XII Inter. Conference on Cold Fusion (Yokohama 2005), p. 117

D12 – D. Gozzi et al., *J. Electroanal. Chem.* 452,253 (1998)

D13 – M. McKubre et al., *The emergence of a coherent explanation for anomalies observed in D/Pd and H/Pd systems : evidences for ^4He and ^3H production*, Proc. VIII Inter. Conference on Cold Fusion (Lerici 2000), p. 3

D14 – M. Miles et al., *J. Electroanal. Chem.* 346, 99 (1993)

On completion of Phase 1, quoted in the above-mentioned Progress Report, SRI International sent the President of ENEA – Prof. Luigi Paganetto, who succeeded Prof. Carlo Rubbia – a letter partly reproduced in the two following excerpts:

“...Together with ENEA, Energetics and NRL (The US Naval Research Laboratory), we have just finished Phase I of what may prove to be a milestone forward step in condensed matter nuclear research. The team has successfully replicated at SRI experiments initially performed by Energetics in Israel. Our results were reviewed two weeks ago by DARPA (The US Defense Advanced Research Projects Agency, Washington DC) and other government scientists. We reported very high levels of power gain (heat out / energy in) and high levels of reproducibility that were not imaginable as little as a year ago. A full report on this phase of activity is now complete and I will submit it formally next week to my DARPA contract manager. In addition to the obvious contributions of Energetics and superwaves, a very large part of what must be considered a major scientific success is due to the control of palladium metallurgy developed and exercised by Dr. Violante at ENEA Frascati. This contribution is recognized not only at SRI but also at NRL where new collaborations are developing, and now at DARPA. Dr. Violante and I have worked in formal collaboration between SRI and ENEA now for over a decade. I hope this is only the beginning.

Based on the success of Phase I it is expected that the US government will shortly move to an expanded Phase II. In this second round we plan to include with SRI and Energetics, both NRI and ENEA, representing prestigious government institutions on two continents. This design is to perform intentionally identical experiments in the different laboratories. The hoped for object is to obtain similar results in the participating laboratories that will form the basis of a joint publication that can begin to dispel the criticism that nuclear effects in condensed matter are “not reproducible”. This ability to transfer reproducibility would confirm the reality of an effect the existence of which has been questioned for 18 years. ENEA is a crucial component of this planned second phase. Not only has Dr. Violante established a unique level of mastery over the metallurgy of palladium foils that we will need to succeed, he is also familiar with the needed calorimetry and has already performed successful heat producing experiments.”

In reference to such request, on July 3, 2007 ENEA's President entrusted the Scientific Committee with organizing a meeting in order to identify possible ways to achieve the therein suggested collaboration. Besides ENEA, participants included LNR Energetics, SRI International, NRL and "La Sapienza" University of Rome (see the following list of participants).

<i>Prof. Luigi Paganetto</i>	<i>President, ENEA</i>
<i>P.Eng. Giovanni Lelli</i>	<i>Director General, ENEA</i>
<i>Prof. Sergio Martellucci</i>	<i>President, Scientific Committee, ENEA</i>
<i>Dr. Mauro Basili</i>	<i>Assistant to President, ENEA</i>
<i>Dr. Alberto Renieri</i>	<i>Director, FPN-FUS Department</i>
<i>P.Eng. Aldo Pizzuto</i>	<i>Director, FUS Technologies Unit</i>
<i>Dr. Graham Hubler</i>	<i>Head of the Materials & Sensors Branch, Naval Research Laboratory Washington D.C. USA</i>
<i>Prof. Michael Melich</i>	<i>Professor at Post Graduate School of Navy USA, SRI Consultant</i>
<i>Mrs. Alison Godfrey</i>	<i>C.E.O. Energetics Technologies NJ USA</i>
<i>Prof. Mario Bertolotti</i>	<i>Energetics Dept., La Sapienza Univ. Rome</i>
<i>Prof. Concita Sibia</i>	<i>Energetics Dept., La Sapienza Univ. Rome</i>
<i>Dr. Vittorio Violante</i>	<i>FPN-FUS-TEC, ENEA Frascati</i>
<i>Dr. Francesca Sarto</i>	<i>FPN-FUS-TEC, ENEA Frascati</i>

Later on the occasion of the International Conference on Cold Fusion held in Catania (Italy), Prof. Melich – in his role as organizer of the following International Conference on Cold Fusion (ICCF-14) to be held in Washington DC next August 2008 – informed Vittorio Violante and myself on what the program would be. It envisaged that representatives of the various countries, who carried out activities in this discipline, would give their contribution by providing information about the history of Cold Fusion research in their own country.

Actually they would send a volume in their own native language, which would be translated into English and edited by the United States. It would then be published in view of the Conference following the Washington's, in 2009, on the occasion of the 20th anniversary of Cold Fusion discovery, as part of a series of volumes illustrating the "History of Cold Fusion in the World". By the contacts established with field experts all over the world by the Organizing Committee of the Washington's Conference the complete collection is expected to consist of volumes illustrating the

history of research on Cold Fusion in: China, France, Japan, India, Italy, United Kingdom, Russia and the United States.

As regards Italy, Prof. Melich asked ENEA Scientific Committee to take this initiative on. With the approval of ENEA's President, the Scientific Committee agreed with enthusiasm to carry out this task, relying on the professionalism of Dr. Angela Rosati – of the Scientific Committee's Secretariat, who will immediately contact all field researchers included in the Agency's mailing list.

A first draft of the volume "*Italian Cold Fusion History*" was presented and discussed together with the Members of the U.S. International Editorial Board during a meeting held in Rome on February 4, 2008 (see the participant list and agenda reproduced here below)

"ITALIAN COLD FUSION HISTORY" MEETING

MONDAY February 4, 2008 – 9.30 a.m.

ENEA Headquarters Lungotevere Thaon di Revel, 76 - Rome

5th floor – Scientific Committee Hall

<i>Prof. Luigi Paganetto</i>	<i>President, ENEA</i>
<i>P. Eng. Maurizio Urbani</i>	<i>Director General, ENEA</i>
<i>Prof. Michael Melich</i>	<i>Professor at Post Graduate School on Navy - USA</i>
<i>Prof. Faqir Khanna</i>	<i>University of Alberta - Canada</i>
<i>Prof. Claus Rolfs</i>	<i>University of Bochum – Germany</i>
<i>Prof. Edward Eyring</i>	<i>University of Utah – Salt Lake City, UT – USA</i>
<i>Prof. Sergio Martellucci</i>	<i>Chairman, Scientific Committee, ENEA (Rome)</i>
<i>Prof. Francesco Scaramuzzi</i>	<i>INFN – Frascati (Rome)</i>
<i>Dr. Vittorio Violante</i>	<i>ENEA – Frascati (Rome)</i>

AGENDA

- 1. Opening of the meeting*
- 2. ICCF – 15, 20th Anniversary Series – Site proposals*
- 3. Italian Cold Fusion History*
 - 3.a) Format of the volume*
 - 3.b) Draft Definition of the Fleischmann-Pons Effect(FPE)*
 - 3.c) Extent of the field spawned by the Fleischmann-Pons
announcement*

4. *Commissioned Topical Reviews*
5. *Closing of the meeting*

Anybody who might be concerned to find out the results of this meeting can refer to the meeting report, already made known to the authors of contributions to the Italian volume. The most important points of it are listed here below.

3. *“Italian Cold Fusion History”*:

Prof. Melich reminds that:

- a) The “Cold Fusion History” volume series in the various countries will have to be ready to be translated into English and then printed to be distributed during the ICCF-15, that falls on the 20th anniversary of the first Fleischmann-Pons Cold Fusion experiment in March 1989.
- b) This Rome meeting is the first of a series he is to hold in London, Moscow, China and Japan, in order to press for the preparation of five to eight volumes, for those are the countries that contributed to research into Cold Fusion. His U.S. sponsors will finance the publication of the whole English volume series, including therein expenses for translation from the various source languages into English (and vice versa).

3.a) *Format of the volume*

While illustrating the already-distributed draft of the volume, Prof. Martellucci reminds that:

- a) The Italian Editorial Board is made up of he himself, as President of ENEA SC (Scientific Committee), Prof. Francesco Scaramuzzi Associate Member from INFN, Frascati, Rome, Dr. Vittorio Violante – ENEA, Frascati, Roma – and Dr. Angela Rosati – ENEA SC Secretariat.
- b) The contributions received have been inserted in the volume just after the preface by S. Martellucci and an historical introduction by F. Scaramuzzi. They are further subdivided into contributions provided by: ENEA, CNR, INFN, Universities, and Industrial Research Laboratories .
- c) The volume presents some important missing parts – e.g., contributions by Bressoni (Turin) and Mengoli (Padua) who will have to be urged to give their contributions as soon as possible. It

also lacks an accurate scientific editing allowing to assure its reliability and homogeneity with the other volumes of the series.

3 b) Draft Definition of the Fleischmann-Pons Effect(FPE)

It was decided that the definition of Fleischmann-Pons Effect is supposed to be reported in the Preface of each series volume in the following form: ***"The Fleischmann-Pons effect is the production of heat in a hydrogen-in-metal system under unusual circumstances of very high densities of hydrogen. The observed amount of heat produced is at least 1000 times the energy and power densities (Joules or watts per cubic centimeter of the metal) and this is not available in known chemical systems. Also associated with this heat is the production of helium 4 at levels that account for the heat if each atom of He is associated with 20-30 million electron volts of energy. A small amount of tritium, the mass three isotope of hydrogen, and x-rays of energy around 1.5 keV are also observed."***

In original language volumes, the above definition will have to appear in the same language of the country and translation expenses will be reimbursed by the U.S. sponsors. Likewise the contributions supplied in English will have to be translated into Italian – in the case of Italy – still at the expense of the U.S. sponsors.

3 c) Extent of the field spawned by the Fleischmann-Pons announcement

During the Washington Conference a more accurate definition than the one now existing will be proposed in order to define the scientific research fields which Cold Fusion belongs to. The final definition of FPE will be reproduced in the whole English volume series.

Furthermore, it was agreed with colleagues from the United States to review the volume draft format to be sent to the United States on the occasion of the Washington Conference:

1. The volume, in electronic format, can contain contributions both in Italian (preferably) and in English language so as to avoid any translations from Italian into English that possibly cannot be checked.
2. In order to avoid repetitions making the volume too long, as a rule entire articles already published by other reviews will not be reproduced but in the form of *abstracts*.
3. Contributions are collected based on the of authors' institutional membership, as showed in the volume index.

Eventually, in the same meeting, ENEA Scientific Committee's request for appointing Prof. Francesco Scaramuzzi Member of the International Editorial Board of the initiative as Italy's representative, has been approved by the U.S. colleagues.

As agreed with colleagues in Rome, the volume contains this preface. – whose aim is to show the reader the reason underlying this publishing initiative also by highlighting the role played by ENEA in this research field – followed by the chapters described here below. Each one of them is preceded by short explanatory notes written by myself:

- an Introduction, where articles by Francesco Scaramuzzi – already written in the recent past – are reproduced showing the historical evolution of this research field;
- Research in ENEA Departments in its evolution from 1989 until today;
- Experimental and theoretical Research in CNR (National Research Council) Laboratories, carried out by chemists and physicists;
- Research in INFN (Italian National Institute of Nuclear Physics), both in its National Laboratories in its university Sections;
- Research in Universities, including Institutes, Departments and Sections of INFN (Italian National Institute for the Physics of Matter) hosted by the Italian universities; and
- Research in Industry Laboratories, where we have chosen, as an example, contributions sent by industries still active in the field.

In conclusion, we remind that the Editorial Board of the Italian volume has not altered the authors' contributions except to conform them to this volume's graphic design and to insert them into the above-mentioned Chapters. Any possible integration and/or clarification generally appearing as footnotes has been agreed upon with each respective author. For such reason, authors are the only responsible for their works' content.

On behalf of the Editorial Board, I eventually express my thanks to all those who wanted to give their contribution to the success of this publishing initiative.

CHAPTER 1

ITALIAN COLD FUSION HYSTORY

*(By **SERGIO MARTELLUCCI**)*

1.1. Introduction

This chapter contains some publications written by Prof. Francesco Scaramuzzi, who headed Cold Fusion Research in ENEA from 1989 until his retirement. Today he works at INFN National Laboratories in Frascati, where he is still actively involved in this research field.

Upon proposal by the ENEA Scientific Committee, Prof. Francesco Scaramuzzi has been appointed Member of the International Editorial Board of the volume series about "Cold Fusion History in the World".

In these publications of his the reader will find the historical evolution of Cold Fusion experiments carried out in Italy, along with the description of researchers' mood having to do with these new phenomenons.

1.2. Cold Fusion Research in Italy¹ at the ICCF3 (1993)

FRANCESCO SCARAMUZZI

ENEA - Frascati

The strange geography of Cold Fusion

In the last three and a half years many experiments have been performed in the field known with the conventional name of “Cold Fusion” (CF), and a number of theories have attempted to interpret them and to assess them in a coherent picture. Differently from other fields in Science, this area has grown in a quite strange atmosphere: the most striking aspect of it is the anomalous “geography” of the activities, meaning by this term the different kind of development that research activities in this field have had in different countries.

Before outlining this geography, it could be worth trying to envisage the causes of this anomalous behaviour. One important feature is indeed the difficulty in reproducing most of the experiments in the field. Of course, this feature can be interpreted in positive as a proof of the great complexity of the phenomena under investigation, and in negative as the demonstration that the claimed effects do not exist. Both positions have been brought forward and are still existent: the increasing number of good quality positive experiments, and the improvements in reproducibility seem not to have changed the prevalent scepticism of the scientific community. Anyway, the lack of reproducibility is not the only cause of the scepticism: other features concur in creating it. In particular, the fact that the observed phenomena, if interpreted as nuclear phenomena in condensed matter, cannot be explained by the presently accepted knowledge on nuclear physics. Most striking of all, the experiments showing the production of “excess heat” pose a very intriguing problem: the large amount of energy produced cannot be explained in terms of any known chemical reaction; at the same time, the missing emission of energetic particles (neutrons, tritons, etc.) is in contrast with the expectations of nuclear reactions between energetic nuclei in quasi-vacuum (e.g., plasma), the only ones that are well known presently.

¹ ICCF3 (1993). *Frontiers of Cold Fusion*. In: Ikegami, H. (Ed.), Proceedings of the Third International Conference on Cold Fusion, Nagoya, Japan, October 21-25, 1992, published by Universal Academy Press, Inc., Tokyo.

All these features are at the basis of the scepticism, which is the cause of the “strange geography”; this will be briefly described in the following. Even though it is difficult to perform a clear classification among the countries, an attempt is made to identify groups with similar behaviours.

- The first group consists of the countries in which an official and substantial research activity is going on, with continuous interactions among operating groups. In this group *Japan* excels, counting also on the commitment of Industry and, more recently, of Government (Ministry of International Trade and Industry, MITI). *Russia* (better, the former USSR) , *China* and *India* can be assigned to this group as well.
- The development of CF in the *USA* puts this country in a very peculiar position. On one side there are many scientists active in the field, as it is witnessed by the large number of participants to this Conference (55), second only to Japan. On the other side, it has to be noted that, with the important exception of EPRI (Electric Power Research Institute), no Federal Agency, nor University, is substantially funding research in CF.
- As far as Europe is concerned, *Italy* and, to a lesser extent, *Spain* perform a consistent activity, with moderate funding by state Agencies and/or Universities. The activity in Italy, third for number of participants to this Conference (20), is the subject of this paper, and will be treated in more detail in the following.
- The most striking feature in this “geography” is the almost total absence of research activities in the rest of *Europe*. Here, after the negative results obtained in the experiments performed in the spring-summer of 1989, mostly under the request of Euratom, every interest in CF seems to have disappeared.

Italian Agencies and Universities active in Cold Fusion

In fact, Italy could also belong to the first group, since many Agencies and Universities are moderately funding research in CF, and the scientists involved in this field have made a few attempts to coordinate each other, organizing meetings and conferences, both national and international (Varenna in 1989, Frascati in 1990, Como in 1991, Torino in 1992).

However, up to now the activity has been mostly the fruit of the personal initiative of the scientists, and never a coordinated proposal of Agencies and Universities.

No position on the scientific validity of the subject has been officially taken and the funds dedicated to CF have been rather modest.

The Agencies are the following:

- INFN (National Institute for Nuclear Physics): it is dedicated to fundamental studies in nuclear and subnuclear physics, and is strongly connected with Universities all around the Country. Most of the funding to CF in Italy comes from this Agency, and is particularly dedicated to the development of sophisticated nuclear detectors.
- CNR (National Research Council): it is the State Agency for Research and operates in all fields of Science, mostly through its own Research Institutes but also through funding of other research institutions, such as Universities. It has contributed to CF mostly through its Chemistry Committee.
- ISS (National Institute for Health): it is an Agency with a wide range of interests in Science, performing research mostly aimed to solve problems of health. Its Physics Laboratory is funding research in CF.
- ENEA (Agency for New Technologies, Energy and Environment): formerly the State Agency for Nuclear Energy, it has been recently restructured with the assignment of wider research tasks. After the first success of a Frascati Group in 1989, research in CF has been performed on a modest resource level and mostly on voluntary basis: recently the new Board of Administration has expressed an interest in the field, that hopefully will bring to a serious commitment of this Agency in CF.
- Various Universities participate to research activities, most of them in collaboration or with the funding of the above Agencies: among them the Universities of Torino, Milano, Padova, Trieste, Bologna, Roma 1, Catania.
- Up to now Industry has been totally absent in this field.

In order to have a feeling about the amount of investments in Italy on CF, the figure referring to 1992 amounts to about 0.5 million dollars, not including expenses for personnel. A number of about 10 scientists, mostly working part-time, is committed all around the Country in research on CF.

Italian Research on Cold Fusion

The Italian participation to this Conference is a good representation of the research going on in this field, even though some active groups did not send contributions. Eleven abstracts were submitted and were accepted for presentation to ICCF3, coming from nine groups.

The experimental papers range from gas loading to electrolysis, from nuclear particle detection to heat excess measurement.

There is also a substantial contribution of theoretical papers. Eight of the papers were eventually presented at ICCF3, and the reader will find them in these proceedings.¹⁻⁸ Three of the papers have not been submitted, for the impossibility of the authors to attend ICCF3: they are all theoretical papers, and will be shortly described hereafter.

- The first (authors A. Tenenbaum and E. Tabet, of INFN, ISS and University of Rome 1) investigates a mechanism of D-D fusion taking place in the lattice of a metal undergoing rapid thermal transients: the abrupt release of elastic energy stored in the metal during the absorption of deuterium could produce micro-hot fusion, which could explain the detection of nuclear particles in gas loading experiments.⁹
- The second (author A. Scalia, of the University of Catania) investigates the behaviour of the fusion cross-section, as a function of the energy of the nucleons, for very low energies.¹⁰
- The third (authors L. Fonda of the University of Trieste, and G.L. Shaw of the University of California at Irvine) analyzes the hypothesis that CF could be catalysed by a not confined quark compound.¹¹

Among the activities not presented at all at ICCF3, two are worth mentioning: that of a Padova Group, and that of a Bologna Group. Their most relevant results will be shortly outlined hereafter.

- Padova (CNR and University): two main kinds of experiments have been performed:
 - Study of the dynamics of D and H-charging in Pd sheets (gas loading), as a function of temperature, reaching D/Pd ratios in the range 0.8-0.9; when working with D, a quite substantial emission of charged particles has been detected with the help of CR-39 detectors, amounting, if interpreted as D-D fusions, to 10^{-19} fusions per second per couple of deuterons.¹²
 - The detection of neutrons emitted by D-charged Ti plates (gas loading), under vacuum after temperature cycles, measured with an advanced detector, has shown the emission of neutron bursts, clearly above background, with energies of about 2.5 MeV.¹³
- Bologna (INFN and University): experiments on the detection of neutrons from D-charged Pd (electrolysis) and Ti (gas loading) have been performed extensively under the Gran Sasso Laboratory of INFN, a well equipped Laboratory more than 1000 m underground, where the background of neutrons is about one thousandth of the value at sea level. A particularly advanced detector system has been developed, able to clearly discriminate neutrons from gamma's, with a

time resolution in the order of 10 ns, and the ability to measure the energy of the neutrons. None of the experiments performed up to now has shown the emission of neutrons that could be ascribed to CF effects.¹⁴

Some relevant results

Among the many results in CF research contributed by the Italian scientific community, two of the experiments presented at this Conference deserve a particular mention, and will be recalled in the following.

- The experiment by B. Stella et al.⁵ performed in the Gran Sasso Laboratory of INFN, in which a sample of deuterated Pd has been stimulated with a neutron flux, while the emission of neutrons was detected at right angle with the neutron beam. The result is qualitatively interesting: it is possible to state that the rate of neutron emission, when the D-charged Pd is stimulated, is higher than the rate obtained with Pd without D. This seems to be a clear indication that the combination of the two, Pd and D, is responsible for nuclear reactions that manifest themselves with the emission of neutrons, confirming the role of the lattice in this new kind of nuclear events.
- The experiment by L. Bertalot et al.⁸ performed at the ENEA Centre of Frascati has provided a novel approach to the heat excess experiments in heavy water with Pd cathode. Taking a couple of features from the Takahashi experiment (see also this Conference), i.e. the “hi-lo” technique and the flow calorimeter, this experiment tries to address the problem of the motion of D atoms in the Pd lattice at high D/Pd ratios. In order to do so, the cathode is mounted in such a way as to face on one side the electrolytic cell and on the other D₂ gas: measuring the permeation of the gas into or out of the cathode seems to be a powerful tool to investigate the heat excess production. The experiment provides a quite convincing confirmation of the heat excess production, with maxima up to about 10 times the heat input at low currents, and to 100% of the heat input at high currents, and presents stimulating correlations between the heat produced and some meaningful parameters, such as the period of the hi-lo procedure, the over potential across the cell, and the D-permeation into the cathode. A transport model, also presented at ICCF3², nicely interprets these correlations.

Among the contributions of the Italian community to CF research it has to be remembered the theory of G. Preparata et al.,¹⁵ which, with a very interesting approach, tries to explain the most intriguing issue in CF, i.e. the possible nuclear nature of the heat excess. Preparata's theory invokes a collective and coherent interaction between the D-nuclei and the plasmas in the lattice (electrons and nuclei), to justify the high rate of D-D fusions and the transformation of the mass defect energy of the reaction into heat, rather than in the well known processes taking place at high energy and in quasi-vacuum.

Conclusions

The lack of official commitment and effective support by the Research Agencies and by the Universities has not prevented Italian scientists from being quite active in performing research in CF. On the other side, it has to be acknowledged that no formal vetoes have been interposed to the free initiative of scientists in this field: on the contrary, some of the Agencies and Universities have moderately funded such an effort.

The quality of the experiments performed in Italy has been increasingly good, and the results obtained are rather outstanding in the general panorama of CF. But it is time to perform a more coordinated effort, keeping in mind that material science aspects, such as the characteristics of the materials used, play a very important role in the development of this topic. Thus, a much more intense effort is required in order to obtain a more substantial progress in the field.

The increasingly convincing results obtained by the whole CF community (this Conference has been particularly comforting in this respect), and the example of the Japanese Government and Industry, which appear to be determined to promoting research in this field, have changed the panorama of CF. There are now signs that also the Italian scientific authorities could consider favouring research in this field in the near future.

References

1. G. PREPARATA (INFN and University of Milano), *Theory of Cold Fusion in Deuterated Palladium, this Conference*
2. A. DE NINNO, V. VIOLANTE (ENEA, Frascati), *"Quasi-Plasma" Transport Model in Deuterium Overloaded Palladium Cathodes, this Conference*
3. D. GOZZI, P.L. CIGNINI, R. CAPUTO, M. TOMELLINI, E. CISBANI, S. FRULLANI, F. GARIBALDI, M. JODICE, G.M. URCIUOLI (INFN, ISS and

- University of Roma 1), *Experiment with Global Detection of the Cold Fusion Products, this Conference*
4. B. STELLA, M. ALESSIO, M. CORRADI, F. CROCE, F. FERRAROTTO, S. IMPROTA, N. IUCCI, V. MILONE, G. VILLORESI, F. CELANI, A. SPALLONE (INFN and University of Roma 1), *The FERMI Apparatus and a Measurement of Tritium Production in an Electrolytic Experiment, this Conference.*
 5. B. STELLA, M. CORRADI, F. FERRAROTTO, V. MILONE, F. CELANI, A. SPALLONE (INFN and University of Roma 1), *Evidence for Stimulated Emission of Neutrons in Deuterated Palladium, this Conference*
 6. E. BOTTA, T. BRESSANI, D. CALVO, A. FELICIELLO, P. GIANOTTI, L. LAMBERTI, M. AGNELLO, F. IAZZI, B. MINETTI, A. ZECCHINA (INFN and University of Torino), *Measurement of 2.5 MeV Neutron Emission from Ti/D and Pd/D Systems, this Conference*
 7. F. CELANI, A. SPALLONE, P. TRIPODI, A. NUVOLI (INFN, Frascati), *Measurements of Excess Heat and Tritium during Self-Biased Pulsed Electrolysis of Pd-D₂O, this Conference*
 8. L. BERTALOT, F. DE MARCO, A. DE NINNO, A. LA BARBERA, F. SCARAMUZZI, V. VIOLANTE, P. ZEPPA (ENEA, Frascati), *Study of the Deuterium Charging in Palladium by the Electrolysis of Heavy Water: Search for Heat Excess and Nuclear Ashes, this Conference*
 9. A. TENENBAUM, E. TABEL (INFN, ISS and University of Roma 1), *Temporal Sequence of Nuclear Signals in a "Dry" Cold Fusion Experiment, abstract presented to this Conference*
 10. A. SCALIA (University of Catania), *Anomalies in Nuclear Fusion for Light Systems at Very Low Energy, abstract presented to this Conference*
 11. L. FONDA, G.L. SHAW (University of Trieste and University of California at Irvine), *Anti-Diquark Catalysis of Cold Fusion, abstract presented to this Conference*
 12. C. MANDUCHI, G. ZANNONI, G. MILLI, L. RICCARDI, G. MENGOLI, M. FABRIZIO (CNR and University of Padova), *paper submitted to "Nuovo Cimento"*
 13. C. MANDUCHI (University of Padova), *private communication*
 14. C. MORONI (INFN and University of Bologna), *private Communication*
 15. T. BRESSANI, E. DEL GIUDICE, G. PREPARATA (INFN and Universities of Milano and Torino), 1989, Nuovo Cimento 101A, 845; G. PREPARATA, *Proceedings of the "First Annual Conference on Cold Fusion"*, National Cold Fusion Institute, Salt Lake City (USA), 91 (1990)

1.3. Ten Years of Cold Fusion: An Eye-witness Account¹

FRANCESCO SCARAMUZZI

ENEA - Frascati

There is still no effective dialogue between the CF community and the traditional scientific world. There are extremes on both sides: some claim that CF does not exist, others are convinced that we have already solved the energy problems of mankind. Nonetheless, many good experiments and publications have been produced on this subject and research in this field has certainly made progress. Some of the phenomena known under the name of CF are undoubtedly real, in particular the production of excess heat and its nuclear origin.

Introduction

Two years ago I wrote the article published here below: this can justify its title – “Ten Years Of Cold Fusion: An Eye-witness Account” – if we date back to the very beginning of Cold Fusion's (CF) adventure, i.e., on March 1989. The article was published last year in issue n. 1-2 of Volume 8 of the US Journal “Accountability in Research” (subheaded “Policies and Quality Assurance”). The Journal tries to make the social and ethical aspects of research understood, by examining those sectors characterised by particularly interesting situations.

CF certainly is one of these sectors and my friend and colleague Scott Chubb – researcher at the Naval Research Laboratory in Washington – was encharged of editing the publication of a special issue on this subject. The 8 authors consulted by Dr Chubb were not assigned any ‘task’ but were left free to express what their thought was, although keeping in mind the nature of the Journal the articles would be published in.

I found it natural to write an article witnessing my personal experience in CF research: first being part of ENEA researchers staff at Frascati Research Centre until mid-1995. Then – since I retired – I kept up research as senior advisor at ENEA’s Fusion Division. I sensed that what we had done – especially within our Group – was not known and deserved a description – though necessarily brief – and an ethical and sociological analysis .

¹ The article was published in the ENEA “Energia, Ambiente e Innovazione” Review no. 5/2001.

I was also inspired by my will of showing that our research has been carried out based on a rigorously scientific approach, which led to remarkable results and contributed to the whole sector's progress.

Seemingly this last point is somewhat polemical but has the intent to object the aura of "non-serious science" that always accompanied CF and that we, researchers in the field, have clearly perceived.

When the Editorial Board of the well-known ENEA journal – "Energia, Ambiente e Innovazione" – proposed me to publish the Italian version of my article, I thought it was a good chance to have this analysis of mine known to the world where ENEA operates. I carefully read my article again, and came to the conclusion that what I wrote is still valid, although two years have passed since then. Yet I will add some details to provide additional information about the latest achievements.

Last year, on May 21-26, ENEA organized the "8th International Conference on Cold Fusion" (ICCF8) in Lerici (La Spezia), in the wonderful Villa Marigola. I was the Chairman and the proceedings' editor, whereas Antonella De Ninno was in charge of the Conference's Organizational Office.

The Conference was also under the aegis of CNR (the Italian National Research Council), INFN (the Italian National Institute of Nuclear Physics), and SIF (Italian Physical Society). There were 145 participants, 41 of them were from Italy, 40 from the U.S., 24 from Japan, 12 from Russia. 110 abstracts were proposed and examined by an international commission: out of the 78 accepted papers, 27 were presented as oral speeches and 51 as posters. The Conference Proceedings were edited by SIF by way of Editrice Compositori (publisher) in Bologna and published last February into a some-500-page volume, numbered 70 in the "Conference Proceedings" series. It contains 68 articles which were previously subjected to the judgement of a referee.

ICCF8 revealed the typical panorama of science at its dawn, progressing hard and slow mainly due to the limited resources dedicated to it. Yet it has now reached important scientific achievements and gives us interesting outlooks as to their application. This is not the proper place to make an accurate analysis of results, but I wish to remind that important confirmation exists about the revelation of helium as the 'ashes' of CF process. Which is an indisputable confirmation of the nuclear nature of the observed phenomena.

A sad note dominated the Conference: a month earlier Giuliano Preparata passed away. He was one of the most engaged physicists in research into CF who made valuable theoretical and experimental contributions to it. Not long ago Giuliano successfully promoted the launching of a research initiative by ENEA at the Frascati Centre. Such an initiative got underway, a new laboratory was set up and is still operating, and Giuliano spent the last year of his life at the Frascati Centre dedicating himself full-time to transmitting his enthusiasm and culture to all of his collaborators, including myself. One of his ideas began to produce results which were presented at ICCF8. Such activity is still going on and I wish that the seed sown by Giuliano Preparata could bear fruit.

In conclusion I am ever convinced that the phenomena known as CF are real. In my opinion it is a science field of the greatest fundamental interest, even because it allows to study an example of quantum behaviour of matter in macroscopic systems. Though maintaining a prudent attitude about the application prospects, I think that as to the results achieved by deuterium charging in palladium, it can no longer be denied that this is the 'cleanest' form of nuclear energy ever found. All energy is transformed into heat without any perceptible nuclear radiation emission nor traces of radioactive waste. Although the energy quantity revealed so far is small and the ways of using it are still to be defined, this prospect should deserve major attention by the scientific community. Let me express all of my gratitude and appreciation to ENEA for its proven availability to conduct research into such a field.

The name of Cold Fusion (CF) comes from the interpretation given to certain phenomena taking place in a metal lattice roughly at room temperature, in terms of nuclear fusion, say between two deuterium nuclei: cold in comparison with the high temperatures of thermonuclear fusion (10^8 K). The first time this was suggested was in the Spring of 1989, ten years ago, by Fleischmann and Pons¹: their experiment gave rise to much turmoil all over the world, ending within a few months with the scientific community rejecting the experiment and thus this interpretation. Research in CF continued nevertheless in a few laboratories, mostly in the USA, Japan, Italy, Russia and China; International Conferences were held regularly, roughly every 1.5 years. However, after ten years, in spite of undeniable (although not overwhelming) progress in the field, there is hardly any communication between this small CF community and the scientific world at large.

I have been active in this field since the beginning, and I have experienced with distress the lack of communication with the rest of the scientific world, mostly because I am aware of the rigorous scientific approach with which the research has been performed by the ENEA Group in which I have been operating in Frascati. I think that I can contribute in assessing the present situation of CF, both from a scientific and from a “social” point of view, by acting as a witness of these ten long years.

To start with I will address two of the issues that have been keys to the present lack of communication: the problem of reproducibility and the anomalous nuclear features of the experimental results (*Some Problems*). Then I will try to tell the story of CF as I lived it, which means from my own point of view and in the light of my personal experience: I hope that this report will make clear the logical evolution of the research performed by the ENEA Group of Frascati, resulting in significant progress in the attainment of reproducibility (*Narrative*). I will then try to make a few general statements about the entire field, in order to give some sense of the present state of the art of CF, but without any intention to give an exhaustive review of this discipline, which is not the scope of this Journal (*State of the art*). In the last section I will try to draw some conclusions, point out some prospects for the future, and make some comments on communications between the CF community and the rest of the scientific world (*Conclusions*).

Some problems

I think that two problems, lack of reproducibility and anomalous nuclear features, need to be assessed clearly, because they have been serious concerns of the scientific community, resulting in deep skepticism towards CF. This is what I will try to do in the following.

Reproducibility

Recently I was watching a TV-show, one of those designed to explain science to the layman. A well known physicist was asked what he thought of CF. His answer was that it was not good science, because of the lack of reproducible experiments. I wrote to him, presenting the following arguments:

- a) I agree that reproducibility is a "must" in experimental research;
- b) however, a new field, at its beginning, is often characterized by lack of reproducibility, and it is the task of the scientists operating in that field to understand what is going on, in order to pursue reproducibility;

c) this has been done in the case of CF, making meaningful, even though slow, progress (I sent him a paper of mine² in which I had discussed this problem).

My letter did not produce any effect, in the sense that he did not change his mind, and went on demanding reproducibility, as if it were an intrinsic characteristics of research and not something that has to be pursued.

In order to clarify the issue, let me try to propose a few statements about reproducibility. First, what does it mean? Consider a simple desk-top experiment. When you perform it, you choose your sample, you work out a procedure (a protocol), and you get your results. It is reproducible if you obtain the same results with the same kind of sample and the same protocol every time you perform your experiment. A further stage of reproducibility consists in describing your experiment in a scientific publication, with the consequence that any other scientist who performs the same experiment, on the basis of that paper, obtains the same results. Now imagine that you perform your experiment, take note as accurately as you can of its parameters (sample and protocol) and when you repeat it you do not get the same results: the experiment is not reproducible! There are two possible explanations: either the first experiment was wrong, or you did not have the same kind of sample, or follow the same protocol. If, by examining your first experiment, you reach the conclusion that the measurement itself was correct and reliable, you have to accept the second explanation. At this point you start a further stage of your research: you try to understand which features were hidden in the choice of the sample and in the protocol, that could have influenced your results without your being aware, and thus you begin what may be a difficult march towards reproducibility. It is not correct to state, as many have done for CF, that non-reproducibility necessarily means a wrong experiment.

An episode that I will now describe will help to illustrate my previous statements: it occurred in 1992 to the ENEA Group of Frascati, which I was leading. We had been working on CF experiments based on gas loading of deuterium in titanium, looking for neutrons and tritium, and eventually we had reached the conclusion that we should move to a different type of experiment: the measurement of excess heat in palladium charged with deuterium in an electrolytic cell with heavy water (substantially the Fleischmann-Pons experiment). In order to build the cathodes, we took the only palladium sheet that was at hand in the laboratory, constructed the electrolytic cell and put it in an accurate calorimeter, and performed the experiment: the first three runs, with three

different cathodes taken from the same sheet, and with the same protocol, gave very clear evidence of excess heat production: a couple of orders of magnitude larger than the experimental errors.³ At this point, we had used all the palladium existing in the laboratory, and thus we ordered more of it from the same firm that had provided the previous sample, asking for the same commercial characteristics. When the new palladium arrived, we started another series of experiments, none of which gave any sign of excess heat production. So, there we were: we had no doubt about the correctness of the first measurements, but it had been sufficient to change the sample of palladium for the excess heat to disappear, even though, from a commercial point of view, it was the same kind of palladium. This was the beginning of the project that brought the Group to results quite close to total reproducibility in 1996. I will come back to this subject later.

Many research groups in CF have had similar frustrating experiences. And I am sure that history of science is full of examples of this type, in particular when the sample and the protocol are intrinsically complex. I like to quote a sentence that Wolfgang Pauli wrote in 1931 in a letter to Peierls: "One shouldn't work on semiconductors, that is a filthy mess; who knows whether any semiconductors exist".⁵ Today we are surrounded by semiconductors, and no one has any doubt about the important contribution of Pauli to the development of physics in this century, but in 1931 he was among those who thought that "the measurement was wrong". Conversely, sometimes it happens that, even for complex systems, reproducibility is at hand. This has been the case of high critical temperature (HT_c) superconductors: in 1986, when these peculiar ceramic compounds were discovered, in a few months everybody was able to synthesize them and to check that they were superconducting. Ever since, research on HT_c superconductivity has been widely developed, with a trend, and thus a growth, totally different from CF.

The comparison between HT_c superconductivity and CF, presented first by David Goodstein in the paper that appears also in this issue of AIR⁶, is a good guideline to try to analyze the present state of CF. It is my opinion that the lack of reproducibility has played an important role in the skepticism of the scientific community and in the consequent loneliness of the CF community. It is my personal experience that it is quite frustrating and uncomfortable to work for years in such a situation, sustained only by the knowledge (not the belief) that "the measurement is not wrong". Physics offers today too many opportunities to perform interesting and advanced research (even though perhaps not as interesting

and advanced as CF), leading to more easily reachable rewards, in terms of accepted results, of number of publications, and thus career advancement, to expect scientists to volunteer to perform research in CF. Add to this the substantial *a priori* discrimination that many important scientific journals have applied to papers related to CF, and the lack of resources, both human and financial, and you have a picture that justifies the slow progress of this field. On the other hand, I have just stated that reproducibility has been "almost" reached. Why, then, has nothing changed? The episode that I recounted at the beginning of this section is an indirect answer: one often has the feeling that any attempt to restart communications is doomed in advance. One is tempted to say, as Max Planck is supposed to have said: "A new scientific truth does not triumph by convincing its opponents and making them see the light, but rather because its opponents eventually die, and a new generation grows up that is familiar with it".

Anomalous Nuclear Features

Research in CF is characterized by a large variety of experiments, from electrolytic cells to gas loading procedures, from the measurement of the excess heat produced to the detection of nuclear ashes of various kinds: neutrons, tritium, ^4He and so on. Of course the concept of nuclear ash comes from the conviction that the phenomena under study are nuclear reactions, which is a central point in CF. For the purpose of this section, I will limit myself, without loss of generality, to excess heat experiments, where the large amount of heat produced cannot be accounted for by chemical reactions; thus, by default, it is deduced that it comes from nuclear reactions. The most immediate hypothesis in Fleischmann-Pons type experiments is that a fusion reaction between two deuterium nuclei (deuterons) is responsible for the heat production: this is what was proposed in 1989¹. This reaction has been extensively studied, mostly through experiments performed with the help of particle accelerators, which means in quasi-vacuum and with energetic particles ($>10^5\text{eV}$). This is quite different from the CF experiments, which take place in condensed matter at room temperature (energies of the order of a small fraction of an eV). The following scheme shows the well-known rules for the D + D fusion reaction:

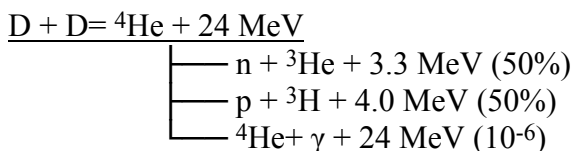

(n = neutron, p = proton, in parenthesis the probabilities of the three final branches). The first step in the reaction is the creation of a ${}^4\text{He}$ nucleus with an excess energy of 24 MeV. In vacuum this enormous energy explains the high probability for this nucleus to decay into two pieces (the first two branches); only very rarely is the excess energy emitted in a γ -ray, leaving an unbroken ${}^4\text{He}$ nucleus (third branch). If a D + D reaction is what happens in CF experiments, then these rules are not at all obeyed, because the amount of thermal energy produced would correspond to a tremendous emission of neutrons (just to cite the only particles that go through almost everything), about 5 orders of magnitude higher than the measured flows.

This (and much more) is what I meant by the title "anomalous nuclear features". It has been said that, in order to justify D + D fusion reactions in CF experiments with deuterium in palladium, three "miracles" are necessary. The first one is a dramatic increase of the probability for fusion to take place. If you try to extrapolate to low energies the known probabilities at high energies, you find that the probability of such an event is some 50 or more orders of magnitude lower than that needed to account for the measured excess heat⁷: in other words, there is no chance that two deuterons will fuse at room temperature. The second miracle pertains to the absence of neutrons (and tritium, and so on) as the ashes of the reaction. You have to assume that the branching ratio (the relative probabilities of the three branches) is also dramatically altered: you must imagine that the first two reactions become highly improbable, while the third, the one giving rise to a ${}^4\text{He}$ nucleus, has a very high probability, almost 100%. But here we need the third miracle, since we do not see any γ -rays: thus we have to make the hypothesis that the 24 MeV of excess energy are in some way transformed in heat in the lattice of the host metal, the excess heat that you measure with your calorimeter. If these three miracles are produced, then the only expected ash is ${}^4\text{He}$: this has been searched for, and in some instances it has been found. But to detect small amounts of ${}^4\text{He}$ is quite difficult, and this is one of the characteristics whose reproducibility is still under investigation.

Accepting the three miracles does not imply a violation of the fundamental laws of physics: in particular, conservation of mass plus energy is satisfied. One possible solution is to suppose that what makes the difference is the fact that the reaction takes place within condensed matter, rather than in vacuum. However, this is not easy to swallow. It has been said that there is no chance that the lattice, with its long characteristic times (10^{-12}s) and large distances (10^{-10}m) can influence

nuclear events, whose typical times are in the order of 10^{-20} s and whose distances are of about 10^{-15} m: to quote Goodstein,⁶ "when the nucleus is doing its thing, the atoms of the crystal are far away and frozen in time". But, at this point, a comparison with the Mossbauer effect (which Goodstein also makes) is quite natural. In some nuclei (¹⁹¹Ir, ⁵⁷Fe, ⁶⁷Zn) the emission of a γ -ray from a nucleus embedded in a lattice can take place in two entirely different ways, depending on macroscopic properties of the lattice, such as the temperature. In one of the two ways, the emitted γ -ray has an extremely narrow line-width, coincident with the natural width, which means that the emission takes place as if the recoil were taken up by the entire lattice. To be sure, the energies involved are quite different with respect to CF (tens of keV instead of MeV's), and theories explaining the phenomenon have been devised and have been accepted by the scientific world. But then, what strikes me is that, however you look at it, a macroscopic parameter of the condensed matter system, the temperature of the lattice, is responsible for switching the emission of the γ -ray from one mode (large line-width) to the other (collective behaviour of the lattice): this means that the lattice is able to influence the performance of a nuclear event. Giuliano Preparata has attempted a different interpretation of the Mossbauer effect⁸ and has proposed a theory for CF⁹, both based on the application of Quantum ElectroDynamics (QED) to condensed matter.

These "anomalous nuclear features" are another reason why the scientific community is very skeptical about CF. Incidentally, even in the CF community there are attempts to interpret the phenomena in terms of (in my opinion unlikely) electromagnetic (i.e., chemical) interactions, which would avoid calling for nuclear events. I think that the experimental evidence of nuclear ashes, including the rather new but impressive field of "transmutations" (see below), even though not as strong as the evidence for excess heat, is nevertheless quite convincing.

Narrative

The Start-up

At the end of March 1989, like many scientists around the world, I was very much impressed by the press news from Utah, reporting the experiments of Fleischmann and Pons¹ and of Steven Jones.¹⁰ I must confess that I was very skeptical about the excess heat results (how can you imagine D + D fusion without neutrons?), and as a physicist I was reluctant to work in such a "dirty" stuff as electrolysis. With a very naive reasoning, that I am sure was shared by many others at that time, I

thought that a more physical approach, such as gas loading of deuterium in an appropriate metal, should succeed as well in obtaining the fusion of two deuterons. I spoke with the two young physicists of the Group, Antonella De Ninno and Antonio Frattolillo, and with the technicians Peppino Lollobattista, Lorenzo Martinis and Luciano Mori, and we decided to try a simple experiment: charging deuterium in titanium with a gas loading procedure and looking for neutrons while performing temperature cycles. We asked and obtained the participation of experts in neutron detection, Marcello Martone and Salvatore Podda, and performed the experiment: in one week we had two extended periods (tens of hours) with an impressive emission of neutrons. This result was communicated to the management of ENEA, a paper was written,¹¹ a patent was issued, and the results were presented in a seminar and in a press conference (the latter seemed to be a common occurrence at that time).

I will not go on recounting what happened as a consequence of these first events: this has been described in the paper by David Goodstein quoted above.⁶ Here I will limit myself to a brief overview of the scientific evolution of our research in the first couple of years. We were soon aware of the very poor reproducibility of our experiment, because we succeeded in repeating the event very seldom over tens of trials. We analyzed our first results many times, wondering whether there was anything wrong, and we could never find any artefact: I am still convinced that those events, even though not reproducible, were real. (Eventually, years later, we learned that another Italian Group had found the same evidence for our second event, following the same procedure¹²). In May 1989 there was a workshop on CF in Santa Fe (NM), organized by the US Department of Energy (DOE) and by the Los Alamos National Laboratory (LANL), and I had the opportunity to contact other groups searching for evidence of neutrons, in particular those of Steven Jones in Provo, Utah, and of Howard Menlove in LANL. As a consequence of the information exchanged, we decided to adopt their sophisticated neutron detectors. The measurements with such a detector were successful, and we presented them at the 1990 March meeting of the American Physical Society in Anaheim (CA) and at the first of the international conferences on CF, held in Salt Lake City also in March 1990.¹³ The data were rather poor and of much lower intensity than our first ones, but consistent with those obtained by the other groups. The next step was designed to reduce the background: we performed a series of measurements in the Gran Sasso laboratory, a very advanced facility 1600 meters under ground, near L'Aquila, Italy, belonging to INFN (Istituto Nazionale di Fisica Nucleare), where the neutron background is reduced by a factor 10^3 .

The result was substantially negative: nonetheless, we reported the results at the Provo meeting in October 1990¹⁴ and at the second international conference on CF, in Como, Italy, in July of 1991.¹⁵ There had been also theoretical attempts to explain our results not in terms of a real cold fusion, but rather as a hot fusion on a microscopic scale, the energy to justify it being provided either by electromagnetic forces¹⁶ or by the mechanical stress induced by the strong temperature gradients produced during our procedure.¹⁷

Summing up the state of the art of our research activity two years after its beginning, we were not happy at all: on the one hand, our efforts to conquer reproducibility were making no progress, on the other hand the explanation in terms of "hot fusion on a microscopic scale" rendered the issue much less interesting than we had hoped. Furthermore, I was still very skeptical about the reality of excess heat measurements, considering neutron and tritium measurements the only relevant and reliable evidence. This conviction was shared by many coldfusioners, and this created a division in the field (what Goodstein⁶ calls the "good" and "bad" kind of CF). The Provo workshop quoted above was dedicated only to experiments based on the detection of nuclear particles, and I participated in its organization, and I appear as one of the editors of the Proceedings (even though my contribution was quite small).

In this state of mind we participated to the Como Conference in July 1991.

The 1991 Como Conference

I am convinced that the Como Conference was the most important in the short history of CF up to now. What I mean is that in that Conference results were presented that produced a real progress in the field, and influenced the research of the whole community in the following years. I will cite here the three issues that I consider most important:

- A. Excess heat versus nuclear emissions. There were many confirmations of excess heat measurements in experiments performed in electrolytic cells, even if the amount of the heat produced was quite variable: it was possible to say that there was a first step forward towards reproducibility. Conversely, the measurement of nuclear emissions, in particular neutrons and tritium, even when accurately performed, gave quite random results, far from reproducibility, and at a very low level, often hardly detectable over the background. The attempt to measure neutron energies gave contradictory results, often with no correlation with any theory. Furthermore, it was very difficult

to find in a single experiment any correlation between excess heat and nuclear emissions: it seemed that they were totally independent of each other.

- B. Excess heat versus D/Pd ratio. One of the most significant results was presented by Mike McKubre *et al.*¹⁸: at SRI (Stanford Research Institute) they had constructed an accurate calorimeter for electrolytic closed cells, and had also developed methods to measure the amount of deuterium absorbed in the palladium cathode, expressed as D/Pd ratio (atomic). This had allowed them to find one of the most important new features of CF: the existence of a threshold of the D/Pd ratio, below which it was not possible to produce excess heat. The value of this threshold, for the experimental configuration of the SRI experiment, was about 0.9-1.0. *A posteriori*, this would explain why CF phenomena were not easy to produce: electrochemists know well that reaching a D/Pd ratio of 0.67 is quite simple, while going beyond this limit is not easy at all. This information had the important result of switching the attention of the experimentalists struggling for reproducibility from the general problem of producing excess heat to the more specific and more controllable problem of overcoming the quoted threshold. It had also an ancillary consequence for me, a physicist totally ignorant of electrochemistry: to understand the main reason why electrolysis is so much more efficient than gas loading in CF experiments. If you look at the phase diagram of the deuterium-palladium compound you find that in order to obtain high D/Pd ratios at room temperature you have to use very high pressures. This is quite impractical in gas loading experiments, and conversely it is unnecessary in electrolysis, where the electrolytic mechanism itself can be considered equivalent to applying very high pressures to the ions entering the metal lattice. It seemed that, until one found a different, more efficient way of loading by gas, electrolysis provided a much better way to reach and overcome the famous threshold.
- C. Another important communication was presented by Melvin Miles of the China Lake laboratory of the US Navy¹⁹. They had collected the gases evolved from an electrolytic cell with which they were performing CF experiments, and had mass-analyzed them with the collaboration of a Group at the University of Texas at Austin, trying to correlate the production of excess heat with the presence of ⁴He in the gases. The correlation was found and was at least qualitatively consistent with the hypothesis presented above, that ⁴He is the relevant ash in this type of experiment. It was the first convincing direct evidence that the excess heat is of nuclear origin.

The results just described had a noticeable impact on the development of CF, and in particular they had an immediate effect on the activity of my Group at ENEA Frascati: we decided to switch from the experiments that we had been doing to experiments with electrolytic cells, looking for excess heat. In fact, there was another Group at ENEA Frascati, including Luciano Bertalot, Francesco De Marco, Aurelio La Barbera and Vittorio Violante: they were mostly doing experiments with electrolytic cells, with heavy water and palladium, looking for neutrons and tritium: one of them (ALB) spent a few months at the Texas A&M University, performing calorimetric measurements on an electrolytic cell, and obtaining clear evidence of excess heat in one run out of three.²⁰ The two Groups merged for this new project.

Excess Heat at ENEA Frascati

I described in section 2a the episode in which the ENEA Frascati Group saw a clear evidence of excess heat production in 1992 and the ensuing disappointment with the "new" palladium. Convinced of the reality of excess heat production, the Group went on trying different experimental arrangements, and trying to address issues that could contribute on the one hand to a better comprehension of the observed phenomena and on the other to the achievement of better reproducibility. I will just cite here some of the features that, in my opinion, contributed to progress in the field.

- A. In the first set of measurements³ the cathode was mounted in such a way that one of its sides was facing the anode, being immersed in the electrolyte, while the other was facing at a sealed volume containing deuterium gas. Monitoring the pressure in this volume gave information on the permeation of deuterium through the cathode. It was found that during the periods of excess heat production deuterium gas flowed from the volume into the metal, the opposite of what happened when there was no excess heat. I do not know what this means, but it is another distinctive feature of this phenomenon.
- B. One of the arguments against the reality of excess heat was the following. Normally it takes a lot of time under electrolysis, sometimes weeks, in order to "charge" the system, so that it can produce excess heat. One could imagine that there is an unknown mechanism of accumulation of energy (common chemical energy) in the system during this phase. At a certain point this energy is released, and is interpreted as excess heat: if this were true, the

phenomenon would be much less interesting, because nuclear reactions wouldn't have to be called for. In two of our experiments we were able to refute this argument. In run n. 3 of the first set of experiments³ the excess heat production started a very short time, minutes, after the beginning of electrolysis and lasted almost 24 hours. In the most spectacular of our results, presented at ICCF5 (5th International Conference on Cold Fusion),²¹ we had the production of a large amount of excess heat, up to 600 kJ, with a peak power of 11W (compared to 8W of power input), in the last three days of a 50-day long run. We had performed an accurate calorimetry of the experiment during the whole run. Thus, we could account for all the heat produced, within experimental error (50mW). If we imagined that all the experimental error was dedicated to this anomalous accumulation of energy, a very unlikely hypothesis, this still could account for less than one half of the total excess heat measured.

- C. In this same experiment a very suggestive feature appeared. While measuring the balance of the calorimeter, to detect excess heat, we were also monitoring the voltage applied to the cell (through a constant current power supply). In the three periods in which excess heat was produced we found that the measurement of the voltage was characterized by a totally different "mode", and the "switch" between the two modes was very abrupt and coincident with the start of excess heat production, as if a transition of phase of the entire thermodynamic system had occurred. The possibility that a phase transition is the basic condensed matter phenomenon that gives rise to CF is quite reasonable: it has been proposed that it could be related to the deuterium ions moving from the octahedral to the tetrahedral sites in the palladium lattice.

The Quest for Reproducibility

The quest for reproducibility has been a central theme of the Group, both because of its intrinsic importance, and because we are aware of the "social" consequences of its lack: the unavoidable "loneliness" with respect to the traditional scientific community, which I discussed above. The importance of having a high value of the D/Pd ratio, which we had learned at the Como Conference, became more and more evident as time went on and thus the episode of the "good" and "bad" palladium could be interpreted in terms of different degree of difficulty in pursuing this objective for different "kinds" of palladium.

This was a clear indication that studying the characteristics of palladium and their relation with the deuterium absorption dynamics was the main route to follow in order to obtain high D/Pd ratios. Eventually the work done on this problem by the young scientists of the Group (Antonella De Ninno, Aurelio La Barbera and Vittorio Violante) yielded important insight into the main reasons for the difficulty of attaining high loading ratios²². As a consequence of these insights, they proposed a protocol for the preparation of the sample, and a particular procedure for the first phase of deuterium loading, which eventually allowed the Group to reach a good level of reproducibility: 5 samples out of 6 that had undergone the whole procedure showed very clear excess heat production.⁴ At this point an intense investment of time and effort was called for, to take advantage of this progress. Unfortunately, what has happened instead in the last few years is that the Group has been reduced from five full-time-equivalent scientists to a staff of two.

I want to mention here another technique to study the dynamics of deuterium in palladium, which was applied in experiments of the Group done in cooperation with another laboratory in the Frascati area (Istituto di Struttura della Materia of the Consiglio Nazionale delle Ricerche): an X-ray diffractometer was used to measure in real time the unit cell parameters during electrolysis, thus observing possible changes in the palladium lattice when high values of loading ratio were attained. This technique worked well²³, but we never reached D/Pd ratios higher than 0.75 in these experiments. This is a very promising technique that should be pursued in a more systematic way. Unfortunately, this was not possible in our case: the experiment was very "expensive", in terms of time and work, and the Group was quite small.

State of the art

Science

Evaluating research in CF is quite difficult, due to the great variety of experiments and of theories that have appeared in this field: I stopped counting publications when the number passed a thousand a few years ago. It is also difficult because, in the absence of normal relations with the traditional world of science, within the CF community there has been too little criticism, and, I would say, a lack of serious refereeing. Thus the papers are not all of good quality, and their results are sometimes questionable. Nevertheless, there are many good experiments and corresponding good papers: there is no doubt that there has been progress in research on CF.

Edmund Storms has tried twice to review it, producing two very detailed papers, complete with very extended bibliographies²⁴. I recommend them to those who want to have detailed knowledge of this field. Here, both because I do not feel able to perform such an enterprise satisfactorily, and because this is beyond the purpose of this article (and of this Journal), I will try to give a short summary of the most important areas: once again, it will reflect my personal view on the field, which does not pretend to be exhaustive.

- A. Let me start with the effort to attain reproducibility. I want to mention here the work of Giuliano Mengoli, in Padua, in which excess heat measurements in electrolytic cells have been performed in different configurations, while working at temperatures close to the boiling point of water. The results are quite reproducible²⁵. (Experiments at "high" temperatures had already been performed by Fleischmann and Pons, who showed also an interesting feature, called "heat after death", i.e., the persistence of heat production after all the electrolyte was evaporated²⁶). Another interesting method worth mentioning is the one followed in the experiments performed by Giuliano Preparata *et al.* The idea is that the presence of an electric potential in the palladium cathode can influence its chemical potential,²⁷ with the effect of allowing higher D/Pd ratios: in this way, excess heat is more easily obtained, without worrying too much about the "material science" characteristics of the metal (the idea arises out of Preparata's theory cited above⁹). In order to have high enough potentials, the cathode is a long thin Pd-wire, with a voltage applied at its ends: the results are quite reproducible²⁸. The route chosen by Francesco Celani, consisting of coating the cathode with appropriate materials in order to prevent the deuterium from escaping is also quite promising²⁹.
- B. There are a number of experiments that seem to show that it is possible to have excess heat production in a different experimental system: nickel and hydrogen rather than palladium and deuterium. In this case the only reasonable explanation for nuclear fusion reactions is the fusion of hydrogen with one of the few deuterons that are always present in hydrogen as impurities. This idea is reminiscent of the work of Julian Schwinger, who examined the possibility of such a reaction as a general explanation of CF³⁰. Excess heat has been detected in light water electrolysis experiments^{25,31}, in electrolysis in so-called "Patterson cells", in which the cathode is constituted by thousands of small plastic spheres coated with layers of palladium and nickel all packed together³², and in gas loading experiments³³.

- C. There has been a growing interest in the detection of "nuclear ashes". A number of careful and refined experiments have been reported that are designed to detect 'traditional' ashes, such as neutrons, tritium, and so on, and to their correlation with excess heat: with particular mention is the work of the Osaka Group led by Akito Takahashi³⁴. There has been an increasing effort to detect ^4He , which is an intrinsically difficult task. The results have been interesting, but the reproducibility has been far from satisfactory: I want to note here a very clear signal found by the Turin Group in a gas loading experiment³⁵ and an elaborate but convincing result by Daniele Gozzi, in which the balance between energy produced and number of ^4He atoms is consistent with the model of $\text{D} + \text{D}$ fusion³⁶. A totally new line of work, known under the name of "transmutations" has been developed in the last few years. Here, in experiments of various types, stable isotopes that were absent at the beginning of the experiment are found. This seems to indicate nuclear reactions other than $\text{D} + \text{D}$ fusion, which is very difficult to understand. There is a wide spectrum of publications on this field, of which I cite just a few representative papers due to the University of Illinois Group led by George Miley³⁷ and to the Sapporo Group led by Tadahiko Mizuno³⁸. This field seems to be expanding, as evidenced in the last conference, ICCF7, held in Vancouver, Canada, in April of 1998.
- D. Much could be said about theories: many and extremely various ideas have been presented. But, once again, I will not try to describe them. Let me just make a couple of general observations. The traditional recurrent mechanism that governs the development of science, alternating theory and experiment, so that they can check each other, is hardly possible if you are still struggling with the lack of reproducibility: this problem has seriously hampered the development of theories. The second observation is that, accepting the nuclear nature of the phenomena of CF, as I do, and considering the arguments discussed in section 2b about the "anomalous nuclear features" of CF, it is not possible to explain CF on the basis of two-body interactions. It is necessary to demand the existence of a collective and coherent mechanism governing the phenomena. Such a mechanism was proposed immediately by Preparata *et al.*⁹ and others, of which I note here Scott and Talbot Chubb,³⁹ has been proposed since then.

The CF Community: Science Versus Utility

A little history is useful in order to better understand the present status of the CF community. As I said at the beginning, towards the end of 1989 there was a rejection of CF by the traditional scientific community, leaving behind a number of ongoing efforts with a particular geographic distribution. In the USA there were many groups operating in spite of the lack of dedicated funds by DOE and NSF. In Japan there was considerable interest from the beginning. Within Europe there was continuing research in a number of groups in Italy, plus a small Group in Spain. China and India were also active, and in due time Russia also showed up. Most of these initiatives were due to small groups, with little or even no funding. Its activity is witnessed by the periodic International Conferences that have been held since then, 8 of them up to now. But there were also three big initiatives that were launched in the years following 1989, that I want to note here:

- A. The Electric Power Research Institute (EPRI) made an important investment in CF research, initially in a number of areas, eventually mostly in excess heat experiments with D/Pd systems, that were performed at the Stanford Research Institute (SRI). This project was active for many years, and was terminated in 1995.
- B. There was an important early project conducted by IMRA, an institution tied to the Japanese industry Toyota (in fact, this was a personal decision of one of the heads of this leading group, Minoru Toyota): three laboratories were created, two of them in Japan (in Sapporo and in Nagoya), and one in Europe, at Sophia Antipolis, near Cannes (where eventually Fleischmann and Pons became active). This project too has been terminated quite recently.
- C. Another important Japanese initiative was taken by the Ministry for International Trade and Industry (MITI) with an additional contribution from a consortium of industries. The project involved a specialized laboratory built for the purpose, and the collaboration of Universities on more fundamental aspects. This project was terminated in 1998.

One could be tempted to interpret the closure of these three important projects as a demonstration that CF research is failing in its objective to become a well defined discipline in science. I am personally convinced that this interpretation is definitely wrong. Let me explain why. One of the common characteristics of these projects is that they were promoted by agencies (in a general sense) that were highly interested in the

potential energetic applications of CF (it is undeniable that the picture that I sketched earlier indicates the possibility to produce particularly clean nuclear energy, which is something mankind has been dreaming for decades). Thus, their expectation was to be able to develop practical applications of CF in a few years. From the description of the progress in science that I have reported above it is clear that, despite indubitable scientific realities, progress in its development has been quite slow, both because of the intrinsic difficulties of the field, and of the very scarce resources that have been dedicated to its study. We are still far from developing applications. Thus, it was to be expected that enterprises that were born with the aim of having a practical fall-out in short time had to give up. I am still convinced that a lot of basic research is needed, in order to better understand the science underlying CF, before practical objectives can be seriously addressed: this can be better pursued by small groups that proceed with this clear idea in mind.

And this is in my opinion what is beginning to happen. Let me mention a few events that show this tendency: it could be (and I hope it is) incomplete, but nevertheless it gives the sense that CF is finally beginning to reenter the scientific world.

- A. At Grenoble, in France, there is a new laboratory funded by the French CEA (Commissariat a l'Energie Atomique) and by the Grenoble Institute Polytechnique, which has started a research project in CF.
- B. The SRI Group, that was funded by EPRI for many years, and then by the Japanese MITI for a couple of years, is presently active in CF research with funds from the US agency DARPA (Defense Advanced Research Projects Agency).
- C. In Italy a new initiative is starting now: a cooperation between ENEA, INFN and LEDA that will allow the creation of a new laboratory at ENEA Frascati with a research program on CF, funded by the Italian Government, for the next three or more years.

Let me mention, to finish, that at the American Physical Society March Meeting of 1999 (the Centennial Meeting) there will be a session, entitled "Palladium Electrochemistry", where papers on CF will be presented.

Conclusions

It has been a long story; let me try to conclude by pointing out some meaningful aspects of this strange adventure of CF, relative to the past, to the present and to the future.

Scientific Realities

There is still no effective dialogue between the CF community and the traditional scientific world. There are extremes on both sides: some claim that CF does not exist, others are convinced that we have already solved the energy problems of mankind. As this paper makes clear, it is my conviction that some of the phenomena known with the name of CF are real, in particular the production of excess heat and its nuclear origin. I am also convinced that it is a very complex matter, that it requires a stronger and longer effort in research, just to understand better the basic phenomena, and that it is too early to consider practical applications. Reproducibility is still an important issue, but much progress has been made, and I think that it is at hand.

Sociology

A reasonable question is the following: How is it possible that after 10 years the extreme positions about CF have not softened, and nevertheless there is a small community (hundreds of scientists) that goes working on with enthusiasm, in spite of the great difficulty that the general skepticism produces? It seems to me that this question has two different answers. The first is connected to the extreme appeal that the theme of CF has on people. There is the hope of solving one of the most serious problems of the world, the problem of energy, and succeeding in the task means pride, honours, money and so on: even if it is very difficult, even if the chances of succeeding are very small, some think that it is worth pursuing this objective. The other answer is that, no matter how you judge the CF community, there are results that are real, for example, the excess heat and the nuclear ashes do exist, in spite of the lack of reproducibility and of all the difficulties that I have tried to describe in this article. If they were not real, the field would have been abandoned many years ago. Add to this that those who started working on it and got positive results believe in the reality of their results and are willing to go on until a better comprehension of the phenomena is acquired, and some practical application is at hand. It is certainly an unusual situation, one that has never happened in the past.

The Role of Chance

I have often wondered about the influence of chance on my personal history. Consider the first episode: we try an experiment that is very naive, we perform it and get tremendous results, twice in a week.

This produces success, excitement, commitment and so on. In two years we realize that it is one of the most irreproducible experiments. Thus, the question comes to the mind: if in our first attempts we hadn't had any neutron emission, what would have we done? The answer is clear to me: we would have abandoned the field after a few more negative attempts, exactly as many others have done, and we would not be involved in research on CF. Now, *a posteriori*, we know that the probability of seeing neutrons in that experiment was very small: thus, chance was the determinant factor in our participating in the CF adventure. Once again, consider the *impasse* in which we were at mid-1991: we were disappointed in the lack of reproducibility in our gas loading experiments, we decided to move to excess heat experiments, we did our first experiments with the 'good' palladium, and saw without any doubt the production of excess heat. Suppose instead that we had started with the 'bad' palladium and saw no excess heat: we would have been thoroughly convinced of the non-existence of excess heat and most probably we would have abandoned the field. Once again chance has been the determining factor in our continuing our activity.

The Future

It is evident that this field requires a more massive effort in order to attain steady progress. Propagation of the research into the rest of the scientific community would greatly contribute to this result. As I said before, I have the feeling that this is beginning to happen, and I am optimistic about future developments. As far as the fields of investigation are concerned, I think that the most recent results indicate that there are three important areas to be pursued: systems that yield excess heat without electrolysis, work at temperatures (at least slightly) higher than room temperature, and work with low dimensionality systems (powders, wires, films).

The reasons "why" one should devote a more massive effort to develop CF are clear to me, and I hope that they are convincing to you, now that you are reading this last paragraph. The study of collective and coherent phenomena promises very high intellectual rewards, and the hope of contributing to the solution of the problem of the energy supply for mankind is highly inspiring. Last but not least, the challenge of studying a field which is not well understood is definitely fascinating. Let me end by quoting Albert Einstein in a sentence that I read during a visit to the Space Museum of Washington: "The most beautiful experience we can have is the mysterious. It is the fundamental emotion which stands at the cradle of true art and true science".

BIBLIOGRAPHY

The "International Conferences on Cold Fusion", of the series ICCFn, starting from ICCF3, will be often quoted in this bibliography. Hereafter are their references: in the rest of the bibliography they will be quoted just by the acronym.

ICCF3 (1993). *Frontiers of Cold Fusion*. In: Ikegami, H. (Ed.), Proceedings of the *Third International Conference on Cold Fusion*, Nagoya, Japan, October 21-25, 1992, published by Universal Academy Press, Inc., Tokyo.

ICCF4 (1994). Proceedings of the *Fourth International Conference on Cold Fusion*, Lahaina, Maui, Hawaii, USA, December 6-9, 1993; published in *Transactions Fusion Technology*, a Journal of the *American Nuclear Society*, 26(4T) (December 1994).

ICCF5 (1995). *Proceedings of the 5th International Conference on Cold Fusion*, Montecarlo, Monaco, April 9-13, 1995, published by *International Conference on Cold Fusion 5*, Valbonne, France.

ICCF6 (1997). *Progress in New Hydrogen Energy*, Proceedings of the *Sixth International Conference on Cold Fusion*, Hokkaido, Japan 13-19, 1996, published by "New Energy and Industrial Development Organization, The Institute of Applied Energy".

ICCF7 (1998). In: Jaeger, F. (Ed.), *Proceedings of the Seventh International Conference on Cold Fusion*, Vancouver, Canada, April 19-24, 1998, copyright by ENECO, Inc.

References

1. FLEISCHMANN M. AND PONS S. (1989). *Electrochemically Induced Nuclear Fusion of Deuterium*, J. Electroanal. Chem., 261:301; see also Fleischmann M., Pons S. Errata (1989) J. Electroanal. Chem., 263: 97.
2. SCARAMUZZI, F. (1997). *La fusione fredda otto anni dopo*. Energia Ambiente e Innovazione ENEA Journal, 1/97:29.
3. BERTALOT, L., DE MARCO, F., DE NINNO, A., LA BARBERA, A., SCARAMUZZI, F., VIOLANTE, V. AND ZEPPA, P. (1993). *Study of Deuterium Charging in Palladium by the Electrolysis of Heavy Water: Search for Excess heat and Nuclear Ashes*, (ICCF3) 365; BERTALOT, L., DE MARCO, F., DE NINNO, A., LA BARBERA, A., SCARAMUZZI, F., VIOLANTE, V. AND ZEPPA, P. (1993): *Study of deuterium charging in palladium by the electrolysis of heavy water: excess heat production*, Il Nuovo Cimento, 15 D:1435.

4. DE MARCO, F., DE NINNO, A., FRATTOLILLO, A., LA BARBERA, A., SCARAMUZZI, F. AND VIOLANTE, V. (1997): *Progress Report on the Research Activities on Cold Fusion at ENEA Frascati*, (ICCF6) 1:145.
5. HODDESON, L., BRAUN, E., TEICHMANN, J. AND WEART, S. (1992). *Out of the Crystal Maze*, Oxford University Press, 121.
6. GOODSTEIN, D.L. (1994). *Whatever Happened to Cold Fusion?* The American Scholar. 63:527; printed also in Engineering and Science, autumn 1994, 14.
7. LEGGETT, A.J. AND BAYM, G. (1989): *Exact Upper Band on Barrier Penetration Probabilities in Many-Body Systems: Application to Cold Fusion*, Phys. Rev. Lett., 63: 191.
8. PREPARATA, G. (1995): *The Mössbauer effect: a glimpse of the stunning QED coherence of matter*. In: Ortalli, I., Ed., ICAME-95 Conference Proceedings, Editrice Compositori, Bologna, 955.
9. BRESSANI T., DEL GIUDICE, E. AND PREPARATA, G. (1989). *First Steps Toward an Understanding of Cold Nuclear Fusion*, Il Nuovo Cimento, 101A: 845.
10. JONES, S.E., PALMER, E.P., CZIRR, J.B., DECKER, D.L., JENSEN, G.L., THORNE, J.M., TAYLOR, S.P. AND RAFELSKI, J. (1989): *Observation of cold nuclear fusion in condensed matter*, Nature, 338: 737.
11. DE NINNO, A., FRATTOLILLO, A., LOLLOBATTISTA, G., MARTINIS, L., MARTONE, M., MORI, L., PADDA, S. AND SCARAMUZZI, F. (1989). *Emission of Neutrons as a Consequence of Titanium-Deuterium Interaction*. Il Nuovo Cimento, note brevi 101: 841; same authors (1989): *Evidence of Emission of Neutrons from a Titanium-Deuterium System*, Europhysics Letters, 9(3): 221.
12. FABRIZIO, M., MANDUCHI, C., MENGOLI, G., MILLI, E. AND ZANNONI, G. (1993). *Emissione di neutroni dall'interazione di deuterio gassoso con titanio e con leghe a base di palladio*. Proceedings of the Rome Workshop on the status of cold fusion in Italy, University of Rome III, February 13-16, 1993, editor Stella, B., 74.
13. D'AMATO, F., DE NINNO, A., LANZA, F., PONTORIERI, C., SCARAMUZZI, F. AND ZEPPA, P. (1990): *Search for Nuclear Phenomena by the Interaction between Titanium and Deuterium*, Proceedings of the First Annual Conference on Cold Fusion, March 28-31, 1990, Salt Lake City, Utah, USA, sponsored by the National Cold Fusion Institute, 170.
14. DE NINNO, A., PONTORIERI, C., SCARAMUZZI, F. AND ZEPPA, P. (1990): *Emission of Neutron Bursts from a Titanium-Deuterium Gas System in a High-Efficiency Low-Background Experimental Setup*, Conference on Anomalous Nuclear Effects in Deuterium/Solid Systems, Provo, Utah,

- USA. Proceedings published by American Institute of Physics (Conference Proceedings 228), editors Jones, S.E., Scaramuzzi, F. and Dorledge, E. (1991).122.
15. DE NINNO, A., FRATTOLILLO, A., LANZA, F., MIGLIORI, S., PONTORIERI, C., SCAGLIONE, S., SCARAMUZZI, F. AND ZEPPA, P. (1991): *The Science of Cold Fusion*, Proceedings of the II Annual Conference on Cold Fusion, Como, June 29-July 4, editors BRESSANI, T., DEL GIUDICE, E. AND PREPARATA, G. (1991). Published by the Società Italiana di Fisica, Conference Proceedings, n. 33: 129.
 16. SEGRE, S.E., ATZENI, S., BRIGUGLIO, S. AND ROMANELLI, F. (1990): *A Mechanism for Neutron Emission from Deuterium Trapped in Metals*, Europhysics Letters, 11: 201.
 17. TABEL, E. AND TENENBAUM, A. (1990). *Displacement flow and deuteron drag in a metal: a path towards cold fusion*, Understanding Cold Fusion Phenomena, edited by RICCI, R.A., DE MARCO, F. AND SINDONI, E. (1989). Conference Proceedings (Varenna, September 15-16) 24, Italian Physical Society, 175.
 18. MCKUBRE, M.C.H., ROCHA-FILHO, R., SMEDLEY, S.I., TANZELLA, F.L., CROUCH-BAKER, S., PASSELL, T.O. AND SANTUCCI, J. (1991): *Isothermal flow calorimetric investigations of the D/Pd system*. The Science of Cold Fusion, Proceedings of the II Annual Conference on Cold Fusion, Como, June 29-July 4, editors BRESSANI, T., DEL GIUDICE, E. AND PREPARATA, G. (1991),Published by the Società Italiana di Fisica, Conference Proceedings, n. 33: 419.
 19. MILES, M.H., BUSH, B.F., OSTROM, G.S. AND LAGOWSKI, J.J. (1991): *Heat and Helium Production in Cold Fusion Experiments*, The Science of Cold Fusion. Proceedings of the II Annual Conference on Cold Fusion, Como, June 29-July 4, editors BRESSANI, T., DEL GIUDICE, E. PREPARATA, G. (1991). Published by the Società Italiana di Fisica, Conference Proceedings, n. 33:363.
 20. BERTALOT, L., BETTINALI, L., DE MARCO, F., VIOLANTE, V., DE LOGU, P., DIKONIMOS MAKRIS, T. AND LA BARBERA, A. (1991): *Analysis of tritium and heat excess in electrochemical cells with. Pd cathodes*. The Science of Cold Fusion. Proceedings of the II Annual Conference on Cold Fusion, Como, June 29-July 4, editors BRESSANI, T., DEL GIUDICE, E. AND PREPARATA, G. (1991). Published by the Società Italiana di Fisica, Conference Proceedings, n. 33:3.
 21. BERTALOT, L., DE NINNO, A., DE MARCO, F., LA BARBERA, A., SCARAMUZZI, F. AND VIOLANTE, V. (1995). *Power Excess Production in Electrolysis Experiments at ENEA Frascati*, (ICCF5) 34.
 22. DE NINNO, A., LA BARBERA, A. AND VIOLANTE, V. (1997). *Selection of*

- Palladium metallurgical parameters to achieve very high loading ratios*, (ICCF6) 1: 192; DE NINNO, A., LA BARBERA, A. AND VIOLANTE, V. (1997): *Deformations Induced by High Loading Ratios in Palladium Deuterium Compounds*, Journal of Alloys and Compounds, 253: 181; DE NINNO, A., LA BARBERA, A. AND VIOLANTE, V. (1997). *Consequences of lattice expansive strain gradients on Hydrogen loading in Palladium*, Phys. Rev. B, 56: 2417; DE NINNO, A., VITTORI ANTISARI, M. AND GIANGIORDANO, C. (1998). *Material science studies aimed at improving the reproducibility of the heat excess experiments*, (ICCF7) 103.
23. BERTALOT, L., DE MARCO, F., DE NINNO, A., FELICI, R., LA BARBERA, A., SCARAMUZZI, F. AND VIOLANTE, V. (1994): *Deuterium charging in palladium by the electrolysis of heavy water: measurement of the lattice parameter*, (ICCF4) 122; FELICI, R., BERTALOT, L., DE NINNO, A., LA BARBERA, A. AND VIOLANTE, V. (1995): *In situ measurement of the deuterium (hydrogen) charging of a palladium electrode during electrolysis by energy dispersive x-ray radiation*. Rev. Sci. Instrum., 66: 3344.
24. STORMS, E. (1991). *Review of Experimental Observations about the Cold Fusion Effect*. Fusion Technology, 20: 433; *Critical Review of the Cold Fusion Effect* (1996). Scientific Exploration, 10: 186.
25. MENGOLI, G., BERNARDINI, M., MANDUCHI, C. AND ZANNONI G. (1998). *Calorimetry close to the boiling temperature of the D₂O/Pd electrolytic system*, J. Electroanal. Chem., 444: 1255.
26. PONS, S. AND FLEISCHMANN, M. (1994). *Heat After Death* (ICCF4) 87.
27. PREPARATA, G. *private communication*
28. PREPARATA, G., SCORLETTI, M. AND VERPELLI, M. (1996). *Isoperibolic Calorimetry on Modified Fleischmann-Pons Cells*, J. Electroanal. Chem., 411: 9.
29. CELANI, F., *private communication*.
30. SCHWINGER, J. (1990). *Nuclear Energy in an Atomic Lattice*. Salt Lake City '90 130; *Nuclear Energy in an Atomic Lattice*, 1 (1990), Z. Phys. D, 15: 221; *Cold Fusion: A HYPOTHESIS* (1990), Z. Naturforsch, 45a: 756; *Cold Fusion: Does It Have a Future?*, Evolutional Trends of Physical Sciences, Springer-Verlag, Germania (1991); *Phonon Representations* (1990), Proc. Nat. Acad. Sci., 87: 6983; *Phonon Dynamics*" (1990), Proc. Nat. Acad. Sci, 87: 8370; *Nuclear Energy in an Atomic Lattice-Casual Order* (1991), Prog. Theor. Phys., 85: 711; *Cold Fusion Theory-A Brief Hystory of Mine*, (1994), (ICCF4) XIII.

31. There are many papers on this subject; a couple of them are quoted here: NOTOYA, R. AND ENYO, M. (1993): *Excess Heat Production during Electrolysis of H₂O on Ni, Au, Ag and Sn Electrodes in Alkaline Media*, (ICCF3) 421; BUSH, R T. AND EAGLETON, R.D. (1994): *Calorimetric studies for Several Light Water Electrolytic Cells With Nickel Fibrex Cathodes and Electrolytes with Alkali Salts of Potassium, Rubidium and Cesium*, (ICCF4) 13.
32. CRAVENS, D. (1996). *Flowing Electrolyte Calorimetry*, (ICCF5) 79.
33. FOCARDI, S., HABEL, R. AND PIANTELLI, F. (1994): *Anomalous Heat Production in Ni-H Systems*, *Il Nuovo Cimento*, note brevi 107 A: 163.
34. TAKAHASHI, A. (1998): *Results of experimental studies on excess heat vs. nuclear products correlation and conceivable reaction model*, (ICCF8) 378.
35. BOTTA, E., BRESSANI, T., CALVO, D., FANARA, C. AND IAZZI, F. (1997): *Measurements on ⁴He Production from D₂ gas-loaded Pd Sample*, (ICCF6) 1: 29.
36. GOZZI, D., CELLUCI, F., CIGNINI, P.L., GIGLI, G., TOMELLINI, M., CISBANI, E., FRULLANI, S. AND URCIUOLI, G.M. (1997): *X-ray, heat excess and ⁴He in the D/Pd system*, *J. Electroanal., Chem.*, 435: 113; erratum: (1998), *Electroanal., Chem.*, 452: 251.
37. MILEY, G.H., NARNE, G., WILLIAMS, M.J., PATTERSON, J.A., NIX, J., CRAVENS, D. AND HORA, H. (1997): *Quantitative Observation of Transmutation Products Occurring in Thin-Film coated Microspheres during Electrolysis*, (ICCF6) 2: 629.
38. MIZUNO, T., OHMORI, T., AKIMOTO, T., KUROKAWA, K., KILAICHI, M., INODA, K., AZUMI, K., SHIMOKAWA, S. AND ENYO, M. (1997): *Isotopic Distribution for the Elements Evolved in Palladium Cathode After Electrolysis in D₂O Solution*, (ICCF6) 2: 665; OHMORI, T., MIZUNO, T. AND ENYO, M. (1997). *Production of Heavy Metal Elements and the Anomalous Surface Structure of the Electrode Produced During the Light Water Electrolysis on Au Electrode*, (ICCF6) 2: 670.
39. CHUBB, S.R. AND CHUBB, T.A. (1998). *Periodic order, symmetry, and coherence in cold fusion*, (ICCF7) 73.

CHAPTER 2

RESEARCH IN ENEA DEPARTMENTS

(By *SERGIO MARTELLUCCI*)

2.1. Introduction

This chapter reproduces the contributions I received in reply to the letter I sent to field researchers operating in the Laboratories of ENEA Departments inviting them to collaborate to the publishing initiative of this volume.

ENEA Scientific Committee – installed by President Carlo Rubbia on February 8, 2005 – collected information on Cold Fusion research carried out in ENEA over a one-year-survey period. Such information is summarized in paragraph 3.6 of the “Scientific Committee Report about present and future programmatic activities of ENEA”, dated May 2006, reproduced integrally here below.

“Since the Fleischmann-Pons’ announcement about the discovery of anomalous phenomena in condensed matter, in 1989, remarkable research activities on cold fusion have been performed all over the world.

Very important contributions were provided by Italy, and in particular by ENEA.

Research activities went on for years, though the initial enthusiasm noticeably reduced as a consequence of the experimental results which gave evidence on the weak reproducibility of phenomena and their hardly- measurable extent. Thus doubts were raised about their very existence.

Today the institutes mostly involved in this research field are SRI International (Menlo Park, California), Illinois University, Osaka University, Sapporo University, Tokyo University, Beijing University and, in Italy, ENEA and INFN. Several private companies are involved in this field as well, Mitsubishi and Energetics Technologies Ltd. (USA) to mention a few.

ENEA’s activities did focus on two kinds of experiments – both in electrolytic cells – carried out with different involvement levels. The major one was an experimental check of Prof. G. Preparata’s theory about deuterium charging in palladium electrodes.

The charging is expected to be also influenced by the electric cathode potential. The experiment was performed with cathodes made up of a very thin wire covered with palladium (~50 μ) and long enough (~ 1 m) to produce a considerable potential drop and it was brought to conclusion in 2002, with the collaboration of a private company, LEDA. It provided charging indications based on the theory and production of nuclear ashes (^4He).

However, it should be pointed out that for effects to be measured the reduced palladium mass employed in the experiments made the use of very sophisticated instruments and complex experimental procedures necessary, with a consequent increase in the statistical uncertainty of results.

Cathodes with useful definitely-superior palladium masses would make a detailed study easier to understand the phenomenon's nature and its scalability to levels allowing for its practical use.

Anyway, the experiment in its canonical configuration can be considered concluded.

The second kind of experiments were performed in collaboration with "Tor Vergata" and "La Sapienza" Rome Universities, and arose out of the experience built up in developing palladium membranes for the fuel cycle of controlled thermonuclear fusion. Metallurgy investigations allowed for the setting up of a patented procedure for obtaining cathodes generating high deuterium charging in palladium for the possible cold fusion. In fact it is known that the necessary condition for cold fusion power emission is the insertion, e.g. by electrolysis, of deuterium atoms into the palladium lattice up to a concentration of order 1 :1. If on the one hand it is rather easy to obtain the charging up to concentrations of order 0.6, on the other higher values are achievable only by way of special approaches or technologies. ENEA's approach allows for high loading with a high degree of reliability and reproducibility. ENEA cathodes raised the international interest and gave rise to a commercial activity which led to selling SRI International and Energetics Technologies Ltd several samples. The achieved results fully came up to expectations due to a remarkable power excess production. Well beyond cathodes production and characterization, ENEA's activities in this kind of experiments concerned, with promising results, the laser-stimulated heat emission start of electrodes properly charged in deuterium.

Such approach allowed cold fusion research to be included as a priority in the collaboration agreement recently formalized by ENEA and Pirelli Labs. Hence they have been assigned special funds by MAP¹.

Activities will go on with the development of metallurgy (at the present time, a second patent is in progress) and laser stimulation.”

The reader can acquire more detailed information directly from both the contributions already reproduced in the Chapter 1 and in those reported in this Chapter.

At present the international collaboration – already mentioned in this volume's "Preface" – of SRI International, Energetics Technologies Ltd, and NRL (Washington-USA) with the research group of the Energetics Department of “La Sapienza” Rome University, directed by Prof. Mario Bertolotti and Concita Sibilìa, is being formalized with ENEA.

Based on the criteria for contribution acceptance already mentioned in the Preface and agreed with the International Editorial Board of the volume series, the contribution sent by Salvatore Scaglione (ENEA Casaccia - Rome) – "*The Production of Neutrons and Tritium in the Deuterium Gas-Titanium Interaction*" by A. De Ninno, F. Scaramuzzi, A. Frattolillo, S. Migliori, F. Lanza, S. Scaglione, P. Zeppa, C. Pontorieri – has not been reproduced for it has already been published in the SIF Conference Proceedings (Bologna) in 1991, Vol 33, “The Science of Cold Fusion”, edited by: T. Bressani, E. Del Giudice, and G. Preparata.

¹ MAP = Ministero Attività Produttive (the Italian National Ministry for Productive Activities)

2.2. Cold Fusion at ENEA Frascati from 1989 to 1998

FRANCESCO SCARAMUZZI

INFN National Laboratories, Frascati

History

At the end of March 1989, following the news on "Cold Fusion" (CF) coming from Utah (1,2), by Martin Fleischmann and Stanley Pons (F&P), who both were working in Salt Lake City, and by Steven Jones, who was working in Provo, also at ENEA, in line with what was happening in the whole scientific community, initiatives got started in order to verify the "astonishing" results they announced.

In Frascati, at FUS Department – the seat officially dedicated to nuclear fusion studies – a programme got underway promoted by the ENEA Direction. It was aimed at investigating the production of neutrons and tritium production within an electrolytic cell with heavy water and a palladium cathode (there was much skepticism about the heat production boasted by F&P). This activity reported by Aurelio La Barbera, an electrochemist from ENEA Casaccia Research Centre who was "lent" to the Frascati Centre on that very occasion.

Almost contemporaneously, still in Frascati another line of research arose spontaneously in the Molecular Spectroscopy Laboratory of the TIB* Department, and in particular in the "cryogenic" facility running in that Laboratory. The core of this initiative was the attempt – maybe naïf but certainly compelling – to avoid the complexities of electrolysis by aiming at direct interaction of metal with gas-phase deuterium. Since palladium was not available at the Laboratory, we thought of replacing it with titanium. Previously used by Jones along with palladium for his own experiments, it was easier to find, cheaper and had a very good deuterium-absorbing capacity. Influenced by the habit of using low temperatures, yet trying to create the conditions for a "non-stationary" situation – one of the ingredients of those days' "recipe" – we thought of putting titanium shavings obtained by a rod worked on a lathe into a vacuum-tight container resilient to high pressure and so built as to be immersed into a liquid nitrogen dewar.

* *Translator's note:* Tecnologie Intersettoriali di Base (Basic Intersectorial Technologies).

Once deuterium gas was loaded into the container (some tens of bars), 77 K periods were alternated with room temperature, thus creating the programmed non-equilibrium conditions. Due to the skepticism on F&P's excess heat, once again the aim was to detect possible neutrons emitted by the system. To such purpose some Fusion Department colleagues were asked for help. Experiments started in early April and considerable results were achieved in a couple of weeks. (See "*Gas measurements (1989-91)*" this chapter).

These results brought the authors and ENEA itself the greatest popularity, with the blessing of the agency's Board of Directors. [The article David Goodstein wrote years later (3) gives a witty description of the situation which came into being at that time]. The popularity gained by the ENEA/TIB Group was certainly disproportionate to the significance of results, but it was not possible to mitigate it notwithstanding the belittling statements by the authors. In particular, the most worrying aspect was the poor reproducibility of results which over time became a "nightmare" for the research line as a whole. Such aspect was stressed by the authors in all of their communications, both written and oral. At the same time, the popularity and involvement of ENEA's Board of Directors assured this activity a future development, even a few months later, when the international scientific community decreed with excessive haste and superficiality that CF was not a serious issue (3). As is common knowledge, from that moment on cold fusion researchers could no longer interact with the mainstream scientific community on serious grounds, and this generated several distortions within that small community.

Research in ENEA went on for a couple of years, with still unsatisfactory results in terms of reproducibility. Financial resources were granted, higher quality instruments were acquired, particularly as to neutron detection; collaborations also at the international level were set up as regards neutrons [LANL (*Los Alamos National Laboratory*, TN, USA), BYU (*Brigham Young University*, Provo, UT, USA)] and tritium (Euratom, Ispra) measurements; an experiment got started in the INFN Gran Sasso Laboratory, a 1700-meter-underground facility, where the background of natural neutrons is reduced by a factor 10^3 if compared with that found on the surface.

In the meanwhile, a set of international conferences took place in which ENEA research groups participated giving their contribution: a *Workshop on Cold Fusion Phenomena*, organised by DOE and by LANL in Santa Fe, New Mexico, in May 1989; the "*Understanding Cold Fusion*

Phenomena” workshop, organized by SIF (Italian Physical Society) in Varenna, on the Como Lake, in September 1989; *The First Annual Conference on Cold Fusion*, organized by the *National Cold Fusion Institute* (a branch of Utah University) in Salt Lake City, in March 1990; the “*Anomalous Nuclear Effects in Deuterium/Solid Systems*” conference, organized by the “heat excess objectors” in Provo, Utah, in October 1990. The Proceedings of this Conference were published by AIP (*American Institute of Physics*).

A turning-point for ENEA research groups was the Como Conference, organized by Tullio Bressani, Emilio Del Giudice and Giuliano Preparata in the week of June 29-July 4, 1991. The conference proceedings were published by SIF in vol. 33 – *The Science of Cold Fusion; Proceedings of the II Annual Conference on Cold Fusion* – of the *Conference Proceedings* series. Both ENEA Frascati groups showed the outcome of their research. The TIB group presented the results, basically negative, obtained from the measurements made at Gran Sasso, and a general report on measurements in “*gas loading*”. During this Conference the CF research outline got rather clearer. If on the one hand heat excess detection was confirmed in many cases, on the other the radiation measurement outline – as to neutrons, tritium and charged particles – appeared to be confused, contradictory and having no relation with heat excess. Moreover, as regards heat excess measurements, two important contributions were set forth. The first was the correlation between heat production and palladium loading atomic ratio ($D/Pd > 0.9$) reported by Michael McKubre's Group of *Stanford Research Institute* (Stanford, CA, USA). The second contribution – presented by Melvin Miles from the *Naval Weapons Center* [China Lake, CA, USA, one of the laboratories coordinated by *Naval Research Laboratory* (NRL)] – deals with the correlation between heat excess and ^4He production, where ^4He is to be intended as the nuclear ash of the process.

Such an outline led the two ENEA Groups to a critical assessment of the activities performed until that moment, thus putting forward a different program. They decided to join efforts in the attempt to measure heat excess by exploiting TIB's thermodynamics and electrochemistry know-how for the achievement of a good calorimetry and the setting-up of the electrolytic cell on the one hand, and FUS Group's for nuclear measurements on the other.

This program was implemented in 1992 and immediate clear evidence of heat excess was found in three subsequent experiments and then reported at the ICCF3 (*3rd International Conference on Cold Fusion*) in Nagoya, Japan. This positive result launched again and stronger the Group's activities. In the following years we kept on measuring heat excess with different geometries and also tried to develop techniques for the measurement of loading (*D/Pd ratio*) and for trace detection of ^4He (See "*Excess Heat Evidence (1993-1996)*", and " *^4He Measurement*" this chapter).

It is worth mentioning here an episode shedding interesting light on the poor reproducibility phenomenon. For the first three experiments indicated above, the Group used the last palladium foil. As the experiment was successful, we ordered more palladium foils from the same supplier requesting they should have exactly the same characteristics as the ones supplied previously. Yet when we made experiments with the "new" palladium, we were no longer able to evidence the production of heat excess. It was then clear that deuterium loading and, therefore, the reproducibility of CF experiments were definitely influenced by the characteristics of palladium depending on the thermal and mechanical treatment it might have undergone. That is why the Group started investigating this phenomenon keeping always in mind: the goal of achieving high loading ratios. At the end of such effort, a new particular treatment was developed for the samples in order to optimize some of the significant parameters. Furthermore a more efficient loading procedure was created. The results achieved were satisfactory: a set of samples they attained heat excess production and a high grade of reproducibility. These achievements were then reported at the ICCF6 Conference in Toya, Japan, in 1996 (See "*Material Science*" *Investigations*, this chapter).

The following years witnessed the decline of the Group. ENEA's Board of Directors was ever reluctant to support this line of research, which was by then surrounded by heavy skepticism from the whole scientific community. What is more, the Group reduced considerably. In 1998 it was made up of myself, Antonella De Ninno and Antonio Frattolillo, the latter being only partially involved in it (See " *^4He Measurement*" this chapter). In the same year a new attempt was made following a proposal put forward by Giuliano Preparata. Besides giving very important theoretical contributions, he had carried out a significant experiment in a laboratory being financed by a private companies in Milan (LEDA). So he proposed ENEA to take part in a joint ENEA-LEDA programme.

Interest came from the political environment too and it seemed that they could count on a considerable financial support. The initiative went on with many difficulties. Yet, in July 1998 the then ENEA Board of Directors (President Nicola Cabibbo, Director General Renato Strada) approved the launching of the program and in 1999 a new laboratory was set up in the Frascati research centre. At the same time, new experiments were being made in the old venues of the Liquefier building by using the equipment put at disposal by LEDA and relying on a financial support provided by ENEA (needless to say that the funds promised by policy-makers did never arrive). The first experiments began and the atmosphere was positive again. Then, unfortunately, Giuliano Preparata passed away on April 24, 2000. After that event – which almost coincided with the “8th International Conference on Cold Fusion”, held in Lerici and organized by ENEA – the Group collaborating with Giuliano Preparata kept on working actively for 2-3 more years attaining very interesting results. This activity is accurately reported on an article by Antonella De Ninno and Antonio Frattolillo, published in this volume. Over time, however, the Group definitely broke up. Besides the report just mentioned, the reader will find an additional report by myself on an experiment begun within the Group headed by Preparata and aiming at investigating the palladium charging with deuterium gas at low temperatures. Finally the volume contains a report by Vittorio Violante on his own research line.

Gas measurements (1989-91)

The experimental equipment was very simple and its scheme is reported in Fig. 1. The sample of titanium shavings was put into a stainless-steel chamber adjacent to a BF_3 neutron counter in which deuterium gas was introduced at a pressure of a few tens of bars. The system was then immersed into a liquid nitrogen (77 K) dewar and taken out in a second moment thus creating non-equilibrium conditions.

Soon two important events, reported in Figg. 2 and 3, occurred. The first one lasted some 40 hours and came about during the sample cooling; the second one occurred at the end of a temperature increase. Both witnessed a neutron emission which was much higher than the background values. At this point, the results achieved were reported during seminars and by way of publications (4). An event very similar to the second one was later experimented by the Padua Group (CNR/University) (5).

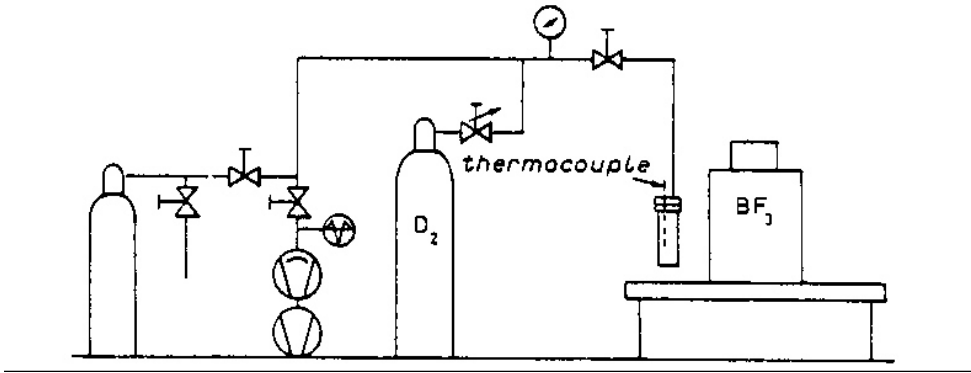

Fig. 1 – The experimental equipment for gas measurements

A modest presence of tritium was evidenced by the “*post mortem*” analysis of the titanium already used (6).

Although many attempts were made to reproduce the occurrence of these events, there were poor results and of lesser importance. Not even better equipment and the Gran Sasso experiments did provide the expected results. Therefore, as already reported in Chapter 1, this research path was abandoned in favour of the attempt to measure excess heat in an electrolytic cell.

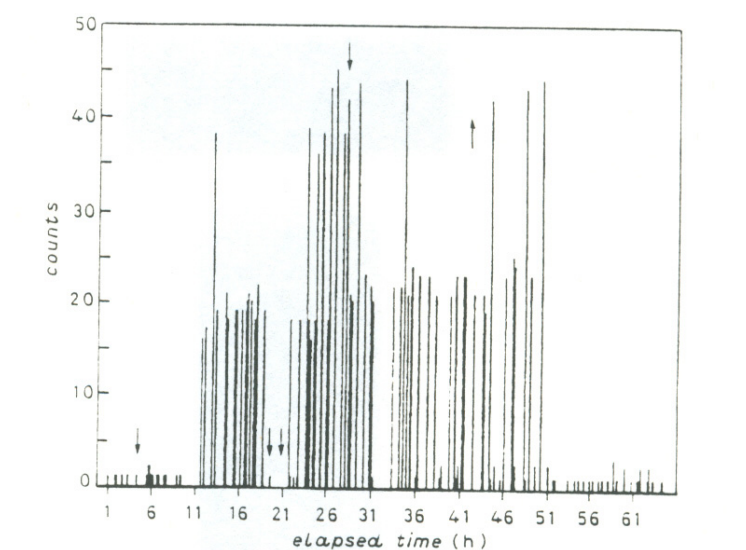

Fig. 2 – The first event (April 7-10, 1989)

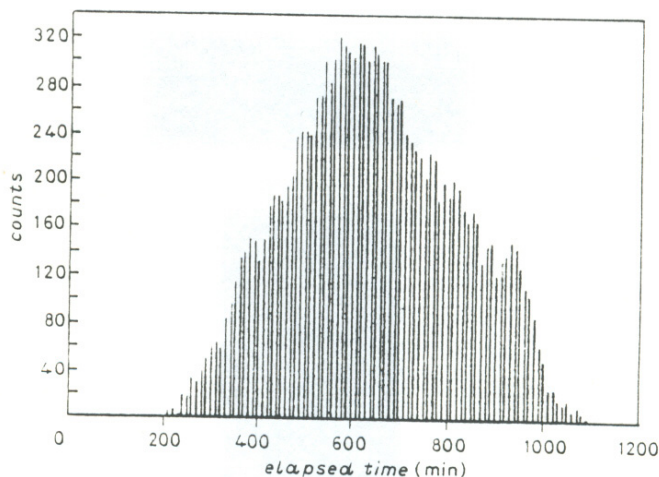

Fig. 3 – The second event (April 15-16, 1989)

In the light of the later information and, in particular, of the hypothesis that the "real" CF in the palladium-deuterium system is the production of heat and ^4He , intended as the only nuclear ash of the process, it seems reasonable that the results reported in this chapter could be included into a new category, that of thermonuclear fusion in a microscopic scale. Such hypothesis was taken into account by some researchers who tried to work out theories accounting for the experimental results. In particular, they proposed a mechanism based on the creation of electric fields when deuterium absorption in palladium occurs (7); another hypothesis was made on a mechanism of mechanical nature caused by the lattice collapse (8). One could also think that these data actually are to be considered as "precursors" of the experiments made by the Taleyarkan Group from *Oak Ridge* producing thermonuclear fusions on a small scale by way of acoustic cavitation (9). Events during the experiments made in Frascati in 1989 were left to chance and hence hardly reproducible. Conversely, for Taleyarkan's they are generated by a specific *trigger*.

Excess Heat Evidence (1992-96)

Fig. 4 shows a scheme of the experiment made in 1992 by the Group resulting from the fusion of the two Groups operating at ENEA's Frascati centre. That same year, in October, the results were reported at the *3rd International Conference on Cold Fusion (ICCF3)*, held in Nagoya, Japan (10). The data were then published on "Il Nuovo Cimento" (11). The particular geometry adopted was aimed at giving evidence of deuterium gas permeation through the cathode. The results attained were very interesting and can be consulted in the above indicated articles, which the reader is invited to refer to.

A flow calorimeter with a sensitivity of approximately 50 mW was used. A technique suggested by Takahashi's Japanese Group was implemented by alternating high and low electrolytic current densities. It is evident that once again the aim was to create non-stationary situations within the system.

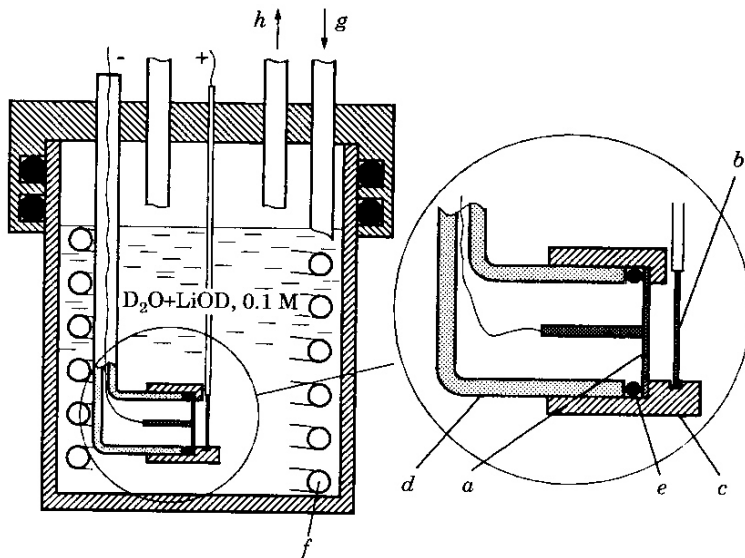

Fig. 4 – Scheme of cell and calorimeter used in 1992 experiments

Special emphasis is given here to the excess heat measurements obtained in all of the three runs of the experiment. Fig. 5 shows the time graph of excess heat production for the second run, with a peak of approximately 3 W resulting at the end of the experiment.

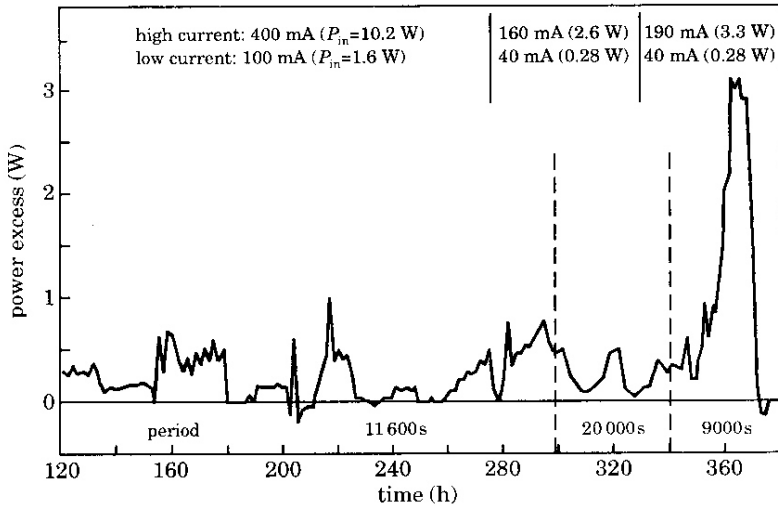

Fig. 5 – Graph of power excess as a function of time, obtained in the second run of the experiment performed in 1992

Following the success obtained in 1992, the ENEA Group's activities expanded in several directions also trying to develop a technique to measure loading ratios and coping with the "material science" issues aimed at overcoming the difficulties which could prevent achieving high loading ratios.

Among the various attempts, it is worth mentioning an experiment performed in 1994, aimed at investigating the influence of the different characteristic parameters of electrolysis, such as, in particular, electrolytic current, molarity of the solution, voltage applied to the electrodes, and so on. In this experiment it was decided to use a palladium anode so that the palladium dissolved from the anode would deposit on the cathode thus causing it to be continuously regenerated. This would have prevented the electrolytic cell from its usual deterioration.

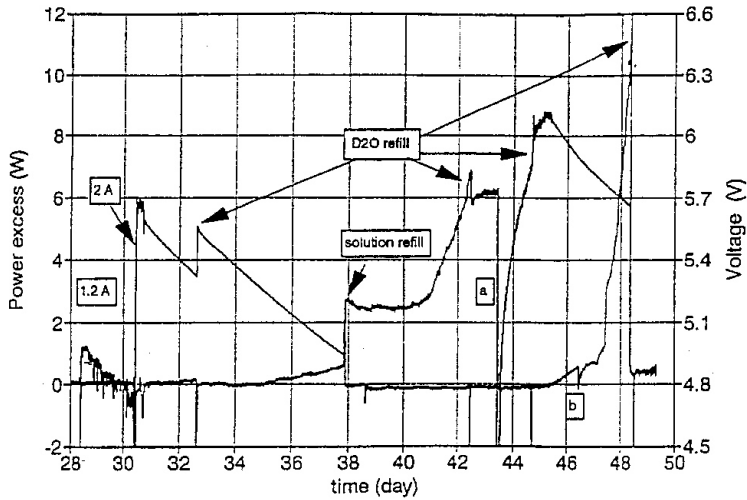

Fig. 6 – Graph of power excess and voltage applied to electrodes, as a function of time, in the 1994 experiment during the last 22 days. Two heat production events occurred at day 35 and day 45.

Actually the experiment lasted almost 50 days. At an advanced phase of the experiment, two heat production events occurred on the 35th and on the 45th day respectively (Fig. 6). The latter was really evident: heat production kept increasing for more than three days up to a maximum value of 11 W. It must be pointed out that the power applied to the electrolytic cell during this episode was about 8 W. Hence, in the last period, the threshold – called in thermonuclear fusion physics *breakeven* – actually had been exceeded.

I like to recall here a particular aspect of such experiment. A constant current was applied to the cell and we had decided to monitor the difference of potential between the two electrodes. This is one of the two parameters showed in Fig. 6 which follows the many vicissitudes of the experiment, in particular the topping-up of the cell with water to compensate the level of electrolyzed water, and the variations in the solution molarity. Yet the most interesting aspect is a very specific behaviour of the applied voltage occurring in both heat production episodes, and in the very moment in which heat excess takes place.

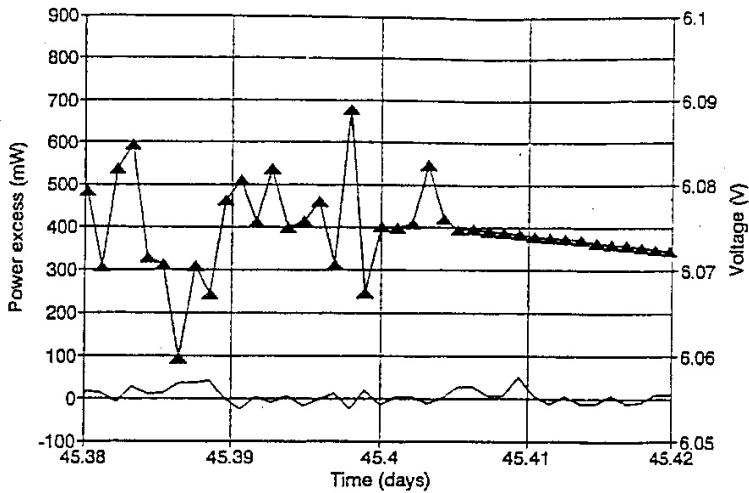

Fig. 7 – Trend of the voltage applied to electrodes as a function of time, at the beginning of the second heat excess episode ($t \approx 45.4$ days)

This is showed in Fig. 7, as regards the second episode: before heat production begins, the voltage value is rather oscillating over time; once heat production begins, the voltage value stops oscillating and gets steady with its decreasing trend accounting for the system's loss of water. One of the hypothesis made attributed normal oscillations to the rise of D_2 bubbles on the cathode surface and to their following detachment. Thus the new situation somehow altered this mechanism. The general feeling was that a phase transition was being witnessed.

The results of this experiment were reported in the ICCF5 Conference, held in Monaco (Montecarlo) in April 1995 (12).

“Material Science” Investigations

Part of the ENEA Frascati Group dedicated a considerable amount of research activities to deepen the specific aspects of deuterium charging in palladium. I will limit myself to a brief mention of the three most significant research routes, inviting the reader to refer to the original articles for more detailed information.

The first route concerned the study of material characteristics and its behaviour in relation with the deuterium absorption (13, 14, 15, 16).

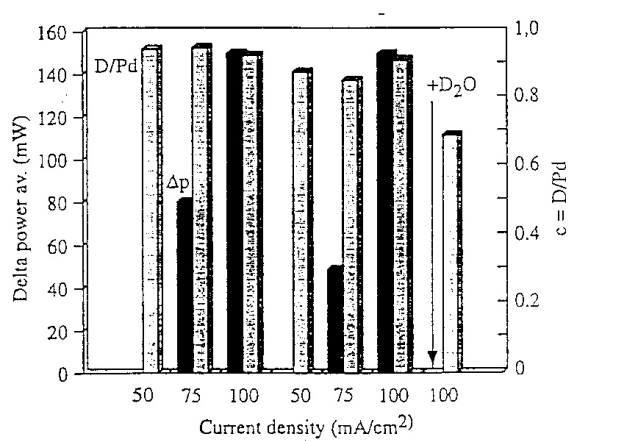

Fig. 8 – The D/Pd relation (light bars) and heat excess (dark bars) in seven subsequent trials: four of them gave clear evidence of heat excess

The mechanisms of deuterium transport in the palladium lattice were studied by correlating the charging with the metal's metallurgy parameters. A practical result of these investigations was the development of a treatment procedure for the samples, along with a different charging procedure, both aimed at maximizing the deuterium charging. These results were the basis on which a set of experiments was carried out in 1995-96 aiming at detecting heat excess. The results were very satisfactory, as reported in Fig. 8, where evidence is given of the correlation between heat excess and charging (17).

Another research route is to be quoted. It is the study of an electromagnetic mechanism allowing deuterons to get closer within the palladium lattice (18, 19, 20).

Eventually, it is worthy of mention the measurement of palladium lattice parameters in real time during electrolysis charging. This research was performed in collaboration with the CNR Institute of Structure of Matter in Frascati and led to very promising results (21, 22, 23).

⁴He Measurement

In early 1996 a measurement system, based on the use of a mass spectrometer, was set up with the aim of detecting the production of ⁴He, to be intended as the nuclear ash of the D + D nuclear fusion process. This measurement is complicated by a set of concurrent factors.

Firstly, the mass of deuterium molecule differs from that of the ⁴He atom by only 0.026 amu. Moreover, the quantity of ⁴He which is to be detected is rather small and usually mixed with a considerable amount of deuterium. Finally, ⁴He is contained in the atmosphere (5.4 ppm), and therefore possible atmospheric 'contamination' should be prevented during measurements.

An original method was developed by employing a quadrupole mass spectrometer used in static mode – i. e., with the quadrupole being statically immersed into the gas to be analyzed – and a *getter* pump, i.e., a pump removing all but noble gases. In this way the deuterium present in the mixture being analyzed could be completely eliminated, leaving only ⁴He. The latter could be measured upon calibration of the spectrometer. Such method and its first laboratory results were reported at the ICCF8 Conference (24).

Conclusions

It seems to me that the history of ENEA Frascati Group has its own internal consistency and is an excellent example of a constructive evolution of research. In 1992, after an accurate assessment of the work done, a substantial change in the research route was made passing from neutron detection to excess heat measurement. The positive results convinced the Group that CF – at least in the form investigated i.e., the production of heat and ⁴He in a palladium-deuterium system – is an important scientific reality. This justified the following efforts. I am convinced that, at least in the "rising" phase, i.e., in the 1992-1996 period, the Group undoubtedly gave a considerable contribution to the progress in the field.

Bitterness is left as this meaningful undertaking did not continue. And regret is left too for the rather slow and almost inefficient progress of the whole sector. I think that this disillusionment can be ascribed to both the widespread skepticism on CF, which since the autumn of 1989 has been pervading the mainstream scientific community in a completely unjustified way, and to the consequent ever-increasing lack of interest by the authorities in charge of research.

References

1. M. FLEISCHMANN, S. PONS, *Electrochemically Induced Nuclear Fusion of Deuterium*, J. Electroanalyt. Chem 261, 301 (1989); see also M. Fleischmann, S. Pons, J. Electroanalyt. Chem 263, 197 (1989)
2. S.E. JONES, E.P. PALMER, J.B. CZIRR, D.L. DECKER, G.L.JENSEN, J.M. THORNE, S.F. TAYLOR, J. RAFELSKI, *Observation of Cold Nuclear Fusion in Condensed Matter*, Nature 338, 737 (1989)
3. D. GOODSTEIN, *Whatever Happened to Cold Fusion*, The American Scholar, Volume 63, Number 4, Autumn 1994; published again on Engineering and Science, Fall 1994
4. A. DE NINNO, A. FRATTOLILLO, G. LOLLOBATTISTA, L. MARTINIS, M. MARTONE, L. MORI, S. PODDA, F. SCARAMUZZI, *Evidence of Emission of Neutrons from a Titanium-Deuterium System*, Europhysics Letters, 9, 221 (1989); A. DE NINNO, A. FRATTOLILLO, G. LOLLOBATTISTA, L. MARTINIS, M. MARTONE, L. MORI, S. PODDA, F. SCARAMUZZI, *Emission of Neutrons as a Consequence of Titanium-Deuterium Interaction*, Il Nuovo Cimento, Note brevi, vol.101 A, 841 (1989).
5. M. FABRIZIO, C. MANDUCHI, G. MENGOLI, E. MILLI, C. ZANNONI, *Emissione di neutroni dall'interazione di deuterio gassoso con titanio e con leghe a base di palladio*, Proceedings of the Conference on cold fusion in Italy, Università di Roma III, February, 14-16, 1993, edited by B. Stella
6. A. DE NINNO, A. FRATTOLILLO, F. LANZA, S. MIGLIORI, C. PONTORIERI, S. SCAGLIONE, F. SCARAMUZZI, P. ZEPPA, *The Production of Neutrons and Tritium in the Deuterium Gas-Titanium Interaction*, from "The Science of Cold Fusion", Proceedings of the II Annual Conference on Cold Fusion, Como, June 29-July 4, 1991, editors T. Bressani, E. Del Giudice, G. Preparata, published by Società Italiana di Fisica, 129 (1991). The same article has been published as ENEA Technical Report, RT/INN/91/47 (1991)
7. S.E. SEGRE, S. ATZENI, S. BRIGUGLIO, F. ROMANELLI, *A Mechanism for Neutron Emission from Deuterium Trapped in Metals*, Europhysics Letters, 11, 201 (1990)
8. E. TABET, A. TENENBAUM, *Displacement Flow and Deuteron Drag in a Metal: a Path towards Cold Fusion*, "Understanding Cold Fusion Phenomena", edited by R.A. Ricci, F. De Marco, E. Sindoni, Conference Proceedings (Varenna, September 15-16, 1989), Volume 24, Italian Physical Society, 175 (1990)
9. R.P. TALEYARKAN ET AL., *Evidence of Nuclear Emission During Acoustic Cavitation*, Science, 295 (2002)

10. L. BERTALOT, F. DE MARCO, A. DE NINNO, A. LA BARBERA, F. SCARAMUZZI, A. VIOLANTE, P. ZEPPA, *Study of Deuterium Charging in Palladium by the Electrolysis of Heavy Water: Search for Heat Excess and Nuclear Ashes*, from "Frontiers of Cold Fusion", Proceedings of the Third Annual Conference on Cold Fusion (ICCF3), Nagoya, Japan, October 21-25, 1992, edited by H. Ikegami, University Academy Press, Inc., Tokyo, 365 (1993)
11. L. BERTALOT, F. DE MARCO, A. DE NINNO, A. LA BARBERA, F. SCARAMUZZI, A. VIOLANTE, P. ZEPPA, *Study of deuterium charging in palladium by the electrolysis of heavy water: excess heat production*, Il Nuovo Cimento, 15 D, 1435 (1993)
12. L. BERTALOT, A. DE NINNO, F. DE MARCO, A. LA BARBERA, F. SCARAMUZZI, V. VIOLANTE, *Power Excess Production in Electrolysis Experiments at ENEA Frascati*, Proceedings of the "5th International Conference on Cold Fusion" (ICCF5), Monte Carlo, Monaco, April 10-14, 1995, 34 (1995)
13. A. DE NINNO, V. VIOLANTE, *"Quasi-Plasma" Transport Model in Deuterium Overloaded Palladium Cathodes*, from "Frontiers of Cold Fusion", Proceedings of the Third Annual Conference on Cold Fusion (ICCF3), Nagoya, Japan, October 21-25, 1992, edited by H. Ikegami, University Academy Press, Inc., Tokyo, 107 (1993)
14. A. DE NINNO, V. VIOLANTE, *Study of Deuterium Charging in Palladium by Electrolysis of Heavy Water*, Fusion Technology, 26, 1304 (1994)
15. A. DE NINNO, A. LA BARBERA, V. VIOLANTE, *Deformations Induced by High Loading Ratios in Palladium Deuterium Compounds*, Journal of Alloys and Compounds, 253-254, 181 (1997)
16. A. DE NINNO, A. LA BARBERA, V. VIOLANTE, *Consequences of lattice expansive strain gradients on Hydrogen loading in Palladium*, Phys. Rev. B, 56, 2417 (1997)
17. F. DE MARCO, A. DE NINNO, A. FRATTOLILLO, A. LA BARBERA, F. SCARAMUZZI, V. VIOLANTE, *Progress Report on the Research Activities on Cold Fusion at ENEA Frascati*, "Progress in New Hydrogen Energy", Proceedings of the Sixth International Conference on Cold Fusion, Toya (Hokkaido, Japan) October 13-18, 1996, Vol.1, 145 (1997)
18. V. VIOLANTE, A. DE NINNO, *Quantum Mechanical Description of a Lattice Ion Trap*, "Progress in New Hydrogen Energy", Proceedings of the Sixth International Conference on Cold Fusion, Toya (Hokkaido, Japan) October 13-18, 1996, Vol.1, 221 (1997)

19. V. VIOLANTE, A. DE NINNO, *Lattice Ion Trap: a Possible Mechanism Inducing a Strong Approach Between Two Deuterons in Condensed Matter*, Fusion Technology, 31, 219 (1997)
20. V. VIOLANTE, *Extended Analysis of the Lattice Radio-Frequency Trap as Possible Collision Mechanism between Nucleus in Condensed Matter*, Proceedings of the Seventh International Conference on Cold Fusion, Vancouver (Canada) April 19-24, 1998, 403 (1998)
21. L. BERTALOT, F. DE MARCO, A. DE NINNO, R. FELICI, A. LA BARBERA, F. SCARAMUZZI, V. VIOLANTE, *Behavior of a Pd membrane during deuterium electrochemical loading: excess heat production*, Proceedings of the 4th International Conference on Cold Fusion (ICCF4), Lahaina, Maui, Hawaii, USA, December 6-9, 1993, published by Electric Power Research Institute, Palo Alto, California, USA, Vol. 1: Plenary Session Papers, 4-1 (1994).
22. L. BERTALOT, F. DE MARCO, A. DE NINNO, R. FELICI, A. LA BARBERA, F. SCARAMUZZI, V. VIOLANTE, *Deuterium charging in palladium by the electrolysis of heavy water: measurement of the lattice parameter*, Proceedings of the 4th International Conference on Cold Fusion (ICCF4), Lahaina, Maui, Hawaii, USA, December 6-9, 1993, published by Electric Power Research Institute, Palo Alto, California, USA, Vol. 2: Calorimetry and Materials Papers, 29-1 (1994). Also published on "Transactions of Fusion Technology, 26, 4T, 122 (1994)
23. R. FELICI, L. BERTALOT, A. DE NINNO, A. LA BARBERA, V. VIOLANTE, *In situ measurement of the deuterium (hydrogen) charging of a palladium electrode during electrolysis by energy dispersive x-ray radiation*, Rev. Sci. Instrum., 66, 3344 (1995)
24. A. DE NINNO, A. FRATTOLILLO, A. RIZZO, F. SCARAMUZZI, C. ALESSANDRINI, *A new method aimed at detecting small amounts of helium in a gaseous mixture*, Proceedings of the Eighth International Conference on Cold Fusion, Lerici (SP), May 21-26, 2000, published by SIF, *Conference Proceedings*, vol. 70, 29 (2001)

2.3 Cold Fusion Research Carried Out at Frascati and at The “Texas A&M University” for Heat Measurement, within a collaboration context

AURELIO LA BARBERA

ENEA - Casaccia

The pioneer phase

The activity started soon after M. Fleischmann and S. Pons announcement, when ENEA decided to check experimentally their striking assertions. A research group was officially constituted. It was made up of chemists from the Casaccia research centre and physicists from the Frascati centre. The latter was chosen as the most suitable seat for performing experiments as it was endowed with the proper architectonic structures, the greatest skills in the nuclear field and the instruments for monitoring neutrons and tritium possibly generated during electrolysis of heavy water.

Some electrochemical cylindrical glass cells were realized. They had a 1 mm-diameter palladium wire, 20 cm long as the central cathode and a 0.5 mm diameter platinum wire, 2 m long as the anode, that was wrapped in the shape of a spiral around the cathode about 1.5 cm distant from it. The cathode was welded to a platinum wire to bring the electrical contact out of the cell. A teflon lid allowed for the electric passage of the two electrodes and had a hole for the emission of the gases produced, for the solution sampling and the topping up of D₂O. The experiment assembling envisaged the contemporary presence of a 4-5 cells group surrounded by three different neutron detectors plus a fourth one placed under the cells. Periodically the tritium concentration of a solution sample through scintillation measurement was estimated.

The experiment was carried on uninterruptedly for more than two months with no neutrons and tritium detection. Therefore it was suspended.

The second phase

After some months, in early 1990 a research group was set up, under F. Scaramuzzi's responsibility. It was made up of L. Bertalot, A. De Ninno, A. Frattolillo (physicists), A. La Barbera (chemist) and V. Violante (chemical engineer), besides the technicians L. Bettinali, D. Lecci, G. Lollobattista and F. Marini.

Much news had come from active groups spread in the world, often about results obtained clumsily, but also from excellent researchers whose reliability was certain. Among the news coming from the latter, one was generally accepted: for any detectable phenomenon (heat, neutrons, tritium or transmutations) to happen, a high loading of the palladium lattice with deuterium atoms was necessary, with the D/Pd atomic ratio close to the unit value. In that moment, the failure in achieving or in maintaining a high loading ratio was considered the main cause of the non-reproducibility of experimental results. Then it was decided to face research following two different directions. The first concerned the study of measurement and the methods for achieving and maintaining high loading ratios. In parallel, the second concerned the calorimetric determination of the electrolytic cells. In most tests the two measurements were carried out simultaneously.

These two lines of activities and the remarkable results attained are largely described in another section written by Prof. Scaramuzzi which the reader is therefore invited to refer to. Here I am going to describe the activities I carried out at the “Texas A&M University” (TAMU).

In early 1990, in fact, the group of Professor A. John Appleby, director of the “Center for Electrochemical Systems and Hydrogen Research” at TAMU was contacted for a scientific collaboration implying hospitality for a researcher of ours. Moreover, also the group of Professor John Bockris and that of Dr. L. Kevin Wolf were operating in the same University. These groups were very appreciated by the scientific community and active in the field of cold fusion with interesting results, the first for tritium excess, the second for neutrons emission. So there was the opportunity to collaborate in a particularly-stimulating environment. Hence I was hosted at Prof. Appleby's laboratories for a three-month stage, a profitable period I spent from mid-September to mid-December of the same year.

The TAMU Experience ^[1]

I realized three experiments with the aim of measuring the heat output from an electrochemical cell hoping to provoke and measure heat excess produced during the electrolysis of heavy water. A commercially-available four-cell Hart Scientific Model 8244 heat conduction calorimeter was used.

In this instrument, that can be used non-stop for a long time, the heat flow between a room producing heat and an inactive twin room, is measured based on the Seebeck effect. In this way the potential difference is proportional to the heat flow coming from the cell. Each of the 4 cells can be calorimetrically calibrated by means of an internal resistor and used in a power range up to 2 W. The whole system is mounted in a large aluminum block that is submerged in a constant temperature water bath. The two twin cells are connected in a differential way so that external thermic effects are cancelled and a long-term stability and reproducibility of the base line are assured. The maximum error in power estimation is 5 mW, while the relaxation time is three hours.

The cells used for the experiment were cylindrical and made of stainless steel, with a teflon lid screwed on the top. The lid has two connectors and a valve to permit a free gas evolution and solvent topping-up. The connector of the palladium cathode (Alpha product 99.997%) was a platinum wire spot-welded and insulated from the solution by using a teflon tape wrapped around it. The anodes were made up of the same platinum wire. The cathodes were degassed under vacuum at 950 °C for one hour. Then they were cooled, washed in ethanol, rinsed in water (deionized) and in heavy water (Aldrich 99.8% atomic in deuterium and activity of about 185 dpm/ml), just before the cell assembling. The solutions were prepared with metal lithium (Aldrich 99.9%), and Sodium deuterioxide (MSD Isotopic 99.8% atomic in deuterium).

In the table below the main characteristics of the three experiments are reported. The second column shows the solutions used, the third one the current densities applied for long periods, the fourth one the maximum current densities applied as pulses lasting from some minutes to a maximum of 30 minutes, and the last one the total duration of the experiment.

Cells	Solution	Current Density (mA/cm ²)	Current Pulses (mA/cm ²)	Time (days)
1	LiOD 0.1M	500-950	1400	62
2	LiOH 0.1M	600-800	1400	60
3	NaOD 5M	600	1400	48

The second cell was used as a control experiment because it was considered free from “cold fusion” phenomena, while the third cell was used to highlight the effects of a cation other than lithium. In both cells no heat excess was measured for the whole experiment duration. On the contrary, cell 1 produced a considerable heat excess.

Such cell was operated for 23 days by imposing different current densities and pulses up to 1400 mA/cm^2 for a maximum of 30 minutes, and then was maintained at 600 mA/cm^2 for five days. Fig. 1 shows the trend of current and of heat excess measured in the following two days. It is evident how the current density was enhanced up to 950 mA/cm^2 for three hours and then decreased at 825 mA/cm^2 . After the relaxation time of the calorimeter a heat excess of about 50 mW was detected. To verify if the calorimeter was working well 111 mW were superimposed by means of the calibration resistor. After the three relaxation hours, the excess increase measured was exactly 111 mW , while three hours after the resistor was turned off a some- 50 mW heat excess was measured again (Fig. 1)

The experimental conditions were maintained for ten days, during which such excess ranged between 50 and 80 mW , that is 12-19% of the cell power input.

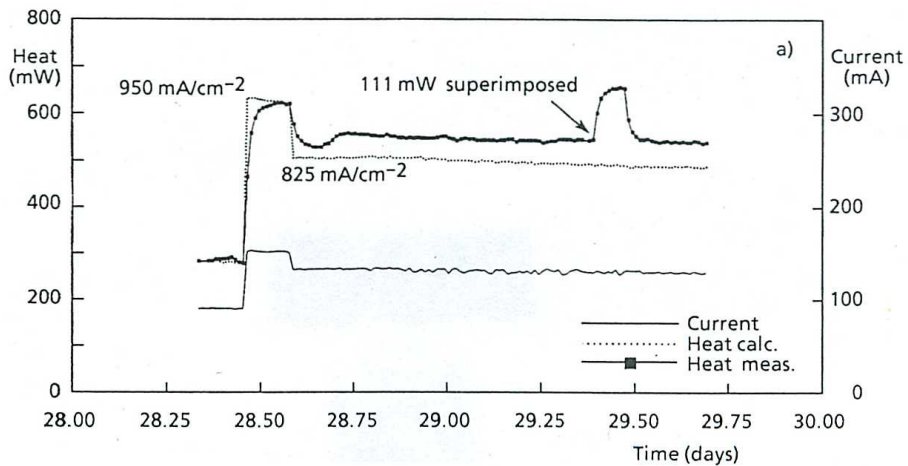

Fig. 1

After that, current density was increased up to 950 mA/cm² for three hours and then decreased at 750 mA/cm², causing heat excess disappear, as shown Fig. 2. The latter also shows that a new attempt to reactivate heat excess was unfruitful. Many other tries were performed during the following 23 days with no result and eventually, after 62 days of non-stop working, the cell was turned off.

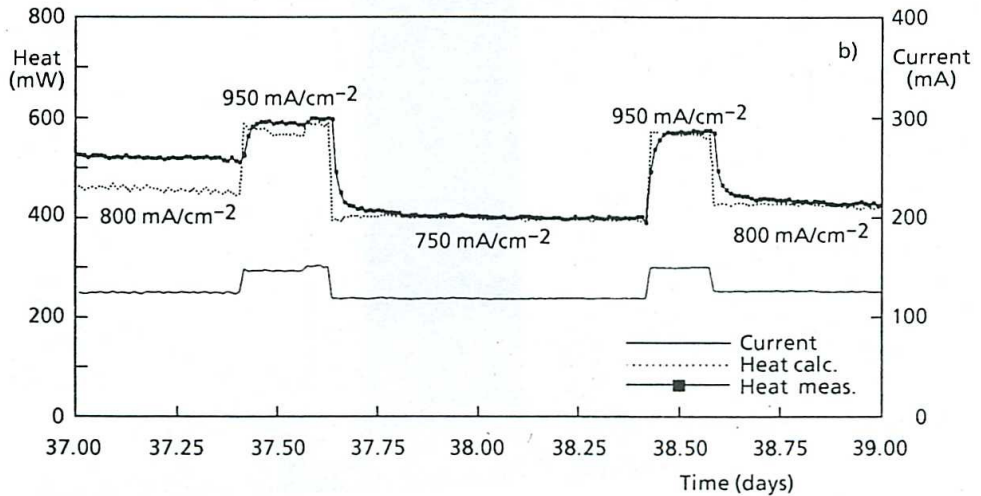

Fig. 2

The table below sums up some significant data of the experiment just described, in particular power density in watt per volume of palladium and the total excess energy produced. Such values were in line with what was then published by other research groups.

Cathode Volume (cm ³)	Current Density (mA/cm ²)	Power Excess (mW) (%)		Power Density (W/cm ³)	Generated Energy (kJ)
		50-80	12-19		
0.002	600-950	50-80	12-19	25-40	57

References

1) L. BERTALOT, L. BETTINALI, F. DE MARCO, V. VIOLANTE, P. DE LOGU, T. DIKONIMOS MAKRIS E A. LA BARBERA (1991)- *Analysis of tritium and heat excess in electrochemical cells with Pd cathodes*. (ICCF2) PROCEEDINGS 3-8 Proc. ICCF2 (1991): The Science of Cold Fusion, Proc. of the Second Annual Conference on Cold Fusion, Como, Italy, June 29-July 4, 1991, edited by T. BRESSANI, E. DEL GIUDICE AND G. PREPARATA, Published by Società Italiana di Fisica

2.4. Historical Reconstruction of Cold Fusion Activities at ENEA

ANTONELLA DE NINNO
ANTONIO FRATTOLILLO

ENEA - Frascati

Cold Fusion is known in Italy since 1989, when the news from Utah about Fleischmann-Pons electrolytic experiments were bounced off our tv and daily paper new. The attention of public opinion was also drawn by the discovery of a shortcut – by a group of Italian researchers headed by Prof. Scaramuzzi from ENEA – to reproduce the odd phenomenon through an apparently-simpler method based on the use of Titanium “sponges”. A media uproar rose with radio, television and newspaper interviews where anyone who thought they had the right to speak on the matter hastened to do so. The then President of ENEA, Prof. Umberto Colombo, convened a press conference to announce the discovery and Prof. Scaramuzzi was even received at the Parliament to be audited on the matter.

The continuation of the Italian issue follows the US example closely: after some months of inspections at ENEA laboratory by international scientific groups and private companies like British Petroleum, it was decreed that the discovery was actually a canard and it was better to stop talking about it. Even ENEA withdrew, Prof. Scaramuzzi obtained the direction but only few funds were assigned to his group during that year, and no funds at all in the following years. Many researchers who tried to get on the triumphal chariot hastened to get off when they realized that things were taking a bad turn. They retracted their results and straight after joined the chorus of detractors.

This rapid opinion change occurred in six months only. Since autumn 1989, saying to have something to do with cold fusion was deeply not recommended in ENEA and in the rest of scientific community.

From that moment onwards, news about could fusion were very poor and this scarcity helped the rising of a legend: many people are asking themselves whether it was actually a canard or a plot was laid to hide an inconvenient research.

As anybody knows, people love legends and poor information paradoxically helped cold fusion stay alive in the collective imagination.

Few people know that, for example, since Spring 1989, three Italian physicists: Giuliano Preparata, Emilio Del Giudice and Tullio Bressani, published an article on the review *Il Nuovo Cimento*, where they laid the foundation of the predictive cold fusion theory.

A non-predictive theory (for example the Ptolemaic theory) is a theory that does not supply the law of a phenomenon formation nor it can make previsions verifiable experimentally. Conversely, a predictive theory anticipates a phenomenon and does not follow it. Their theory provided a satisfactory explanation not only of how the tremendous repulsive barrier between two deuterium nuclei could be penetrated to such a distance as to make the fusion possible without demanding those very high energies requested by thermonuclear (hot) fusion. It also points out the peculiarity of this phenomenon. Unlike all the other known nuclear reactions, it took place in condensed matter and not into vacuum and for it another scenario was to be considered, different from the one dealt with in Nuclear Physics by analogy with the known Mössbauer effect analysis. The peculiarity of this scenario demanded a completely new vision of condensed matter, based on the conceptual developments of quantum electrodynamics. Hence, only the broadening of the acquired knowledge was invoked and not its upsetting. To make a comparison, the revolution of Physics in the early 1900 did not abjure Thermodynamics, but supported it with Quantum Physics necessary to deal with systems with a small number of components.

From the theoretical analysis of Preparata, Del Giudice and Bressani, two very important aspects for experimentators emerged: the existence of a threshold in the ratio between the number of absorbed deuterium atoms and the number of palladium atoms, the so-called loading factor that was expected not to be lower than 1 and the unbalance of the well-known decay channel scheme of the d+d fusion reaction towards ^4He production.

These previsions were already available for the scientific community since May 1989. All of the technical reports, published in the Autumn of the same year, refuting the reality of the Fleischmann-Pons effect contain no indication about the achieved loading ratio and use the occurrence of the total lack of neutrons and charged particles as an evidence of the fraudulence of the assertions by Fleischmann and Pons, and by the whole group of those who, since then, are called “the believers”.

The provisions of the theory by Preparata, Del Giudice and Bressani were later confirmed by the laboratories where those who kept believing more in their own studies than in the holy texts of modern aristotelianism did shut themselves up. The first confirmation of the theory was the existence of a trigger threshold for the phenomenon. Such threshold was linked to the achievement of a loading ratio of deuterium atoms for palladium atoms equivalent to 1. The confirmation arrived almost at the same time from the United States and Japan, and was presented to the III International Conference on Cold Fusion. In 1992 also the first ^4He measurement arrived from Japan, but it was an “off-line” measurement. i.e., samples of gas produced during the experiment were analyzed once the experiment was concluded.

Obviously, the international scientific community, that since the 1989 failure avoided taking into account anything related to cold fusion, did not notice it or pretended not to.

Between the end of 1989 and 1991 at ENEA, Prof. Scaramuzzi's group, which Antonella De Ninno, Antonio Frattolillo and Paolo Zeppa were collaborating with, kept on following the route of gas loading and research on “hard” nuclear ashes such as neutrons, protons and tritium deriving from $d+d \rightarrow ^3\text{He} + e$ and $d+d \rightarrow t+p$ processes

Later on, we realized that neutron measurements were extremely erratic and that reproducibility was remarkably poor. The lack of feedback was such that prevented us from really refining measurements and from actually examining the physical aspects of the problem in depth. So, in 1992, we decided to abandon nuclear measurements and look for confirmations of cold fusion through heat excess measurements from electrolytic cells by using palladium instead of titanium. The group lost the continuative contribution of two of its members (PZ and AF) and merged with the other ENEA group dedicated to the electrochemical aspects and whose members were Vittorio Violante, Aurelio La Barbera, Luciano Bertalot and Francesco De Marco.

The new experimental line undertaken allowed for great progress towards the reproducibility of heat production permitting to establish some steady points in this research: The new experimental line permitted to make great progresses for the reproducibility of heat production phenomenon permitting to establish some steady points in this research:

- heat excess production is a “threshold” phenomenon, i.e., it can be achieved in a reproducible way only if a certain critical value of deuterium charging in palladium is exceeded;
- such threshold is actually the parameter difficult to control explaining for erraticity and the presumed irreproducibility of these experiments;
- checking the metallurgic features of the material and their proper selection permits to achieve palladium samples able to absorb large quantities of deuterium in a reproducible way;

Particularly this last point was evidenced in a series of measurements presented in Conferences also dedicated to subjects other than cold fusion and published on qualified scientific reviews.

Over the years activities were focused on reproducing “Fleischmann-like” electrolytic experiments as well as on studying materials with the aim of achieving high D/Pd ratios.

After years of “underground” work, suddenly, in 1999, an extremely favourable event seemed to happen for cold fusion research in Italy.

In the early months of 1999, Prof. Carlo Rubbia, Noble prize for Physics in 1982, became President of ENEA. His great scientific curiosity lead him to invite Giuliano Preparata – whom he knew well thanks to their common activity in the field of High Energy Physics at CERN in Geneva – to a meeting at ENEA headquarters to talk about cold fusion¹. From that meeting and the interest of the then Director General of ENEA, Renato Strada, a research project began in which besides Giuliano Preparata and Emilio Del Giudice also those ENEA and INFN researchers who had been dealing with that subject for years were supposed to participate. The Project was launched at the end of 1999, without INFN participation.

¹ F. SCARAMUZZI writes in Chapter 2.2. of this volume: “*In the same year (1998) a new attempt was made following a proposal put forward by Giuliano Preparata. Besides giving very important theoretical contributions, he carried out a significant experiment in a laboratory being financed by a private company in Milan (LEDA). So he proposed ENEA to take part in a joint ENEA-LEDA program. Interest came from the political environment and it seemed that they could count on a considerable financial support. The initiative went on with many difficulties. Yet, in July 1998 the then ENEA Board of Directors (President Nicola Cabibbo, Director General Renato Strada) approved the launching of the program ...*”

The project objectives were essentially aimed at checking the theory that got refined over the years: checking the trigger threshold existence, experimenting a new method to obtain the threshold based on the coherence properties of the Pd-D system and, above all, measuring the contemporaneous occurrence of ^4He production and heat excess during the experiment. The measurement was very delicate and was never tried by anyone until that very moment. Only Antonella De Ninno and Antonio Frattolillo took part in the new project on behalf of ENEA, besides a young researcher specially recruited, Antonella Rizzo, since in the meantime the researchers already involved in these activities in the past were assigned other activities. Unfortunately on April 24, 2000, Giuliano Preparata passed away, yet activities went on in the two following years until the project objectives were fully achieved.

The work they carried out evidenced the simultaneous production of enthalpy excess and ^4He during electrolysis of heavy water on a palladium (Pd) cathode; when the stoichiometric ratio $x = [\text{D}]/[\text{Pd}]$ exceeds the critical threshold $x=1$ (see Fig. 1).

This effect was obtained on almost unidimensional resistive cathodes in the form of a coil obtained from a thin film, between 1 and 2 micron thick.

The influence of an electric longitudinal potential applied to the cathode when achieving high loading ratios was proved. This occurrence is a direct evidence of the existence of a condition in the Pd-D system marked by a single wave function and a single phase by analogy with what happens in microscopic quantum systems known at low temperatures (superfluid He). The excess heat was signalled by the local temperature rise measured by commercial Peltier element in good thermal contact with the thin-film cathode substrate.

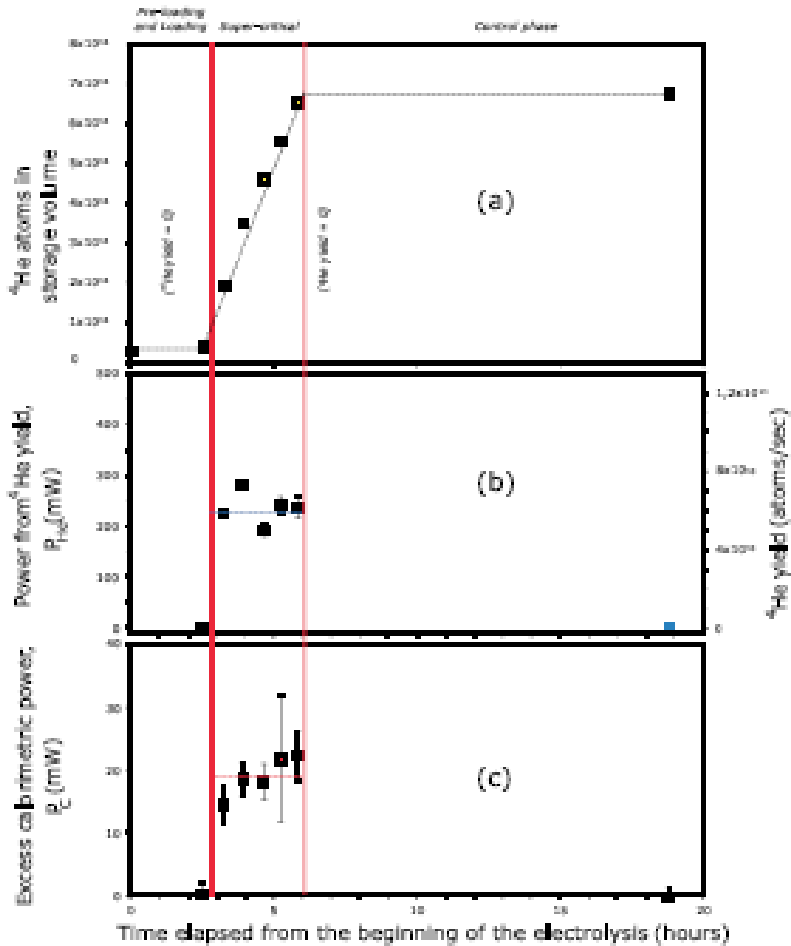

Fig. 1 - (a) ${}^4\text{He}$ content of the gas mixture coming from the electrolytic cell
 (b) Excess Power derived from the number of ${}^4\text{He}$ measured atoms
 ($1 {}^4\text{He}$ atom = 24 MeV)
 (c) Average excess calorimetric power. Data is shown as function of time allowing to check the coincidence



Fig. 2 - The electrolytic cell laid within the thermostated box. The stainless steel UHV containment vessel is missing, thus making electric contacts and the pipes for gases evolved from the electrolysis visible. The electrovalves allowing for automatic gas samples to be sent to the spectrometer for ^4He analysis are visible in the upper side of the cell

The electrochemical cell, entirely made in stainless steel with a Teflon lining, was laid inside a vacuum tight chamber to avoid any possible contamination from outside (Fig. 2).

In order to detect the expected presence of small ^4He amounts, as an evidence of the nuclear nature of the process, simultaneously to enthalpy production an analysis method was set up based on the total removal of all the chemically-active gases present in the gaseous mixture produced during electrolysis.

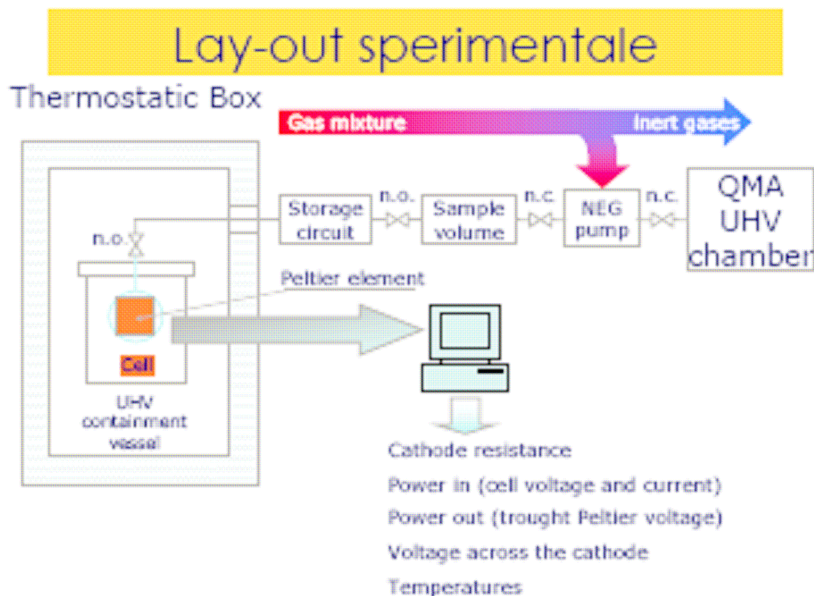

Fig. 3 - Block diagram of the experiment. The upper arrows show the course of the gases evolved from the cell enriching their content with noble gases as they proceed towards the mass analyzer. The lower arrow represents the flow of the electric parameters used for calorimetry

All non-inert components of the gas mixture (especially hydrogen isotopes) are effectively removed by using “Non-Evaporable Getter” (NEG) pumps. Noble gases remain in the gas phase, and are periodically sent to the mass spectrometer to be analyzed quantitatively. The diagram of the experimental lay-out is shown in Fig. 3.

The sophisticated equipment, used for this measurement campaign, has been the object of independent publications and of commercial patents as well. In addition, today the ^4He measurement technique suggested by our group, thanks its the great precision sensitivity, is under evaluation for its possible use as counter of thermonuclear fusion reactions produced in an IGNITOR-like reactor or as leak-test for vacuum chambers of the great Tokamak machines under construction.

The observation of a sizeable transmutation of deuterium into helium proves unequivocally that the so-called “cold fusion” is originated from a nuclear process.

The phenomenon afore-described has been reproduced several times: the quantitative level of helium production in the different experiments obviously depends on the level of deuterium loading in palladium achieved during the experiment.

At the end of 2003, following a seminar held by Antonella De Ninno at CEA headquarters in Paris, a delegation of scientists from the French Atomic Energy Commission (CEA) visited Frascati Laboratories. After the visit an official report was drawn up asserting that ^4He measurement is indisputable and not apparently ascribable to “conventional” causes.

In March 2004, Antonella De Ninno was awarded a prize by the International Society for Condensed Matter Nuclear Science (ISCMNS), for her research demonstrating Preparata’s theory.

During the same year, the Italian Ministry for Productive Activities (MAP), showed interest in the results achieved by the group and in funding a new phase of research aimed at realizing a device able to continuously produce energy quantities of application interest. The experimental activities aimed at verifying Prof. Preparata’s theory, stopped in the early months of 2003².

² E. DEL GIUDICE writes in Chapter 5.2. of this volume: “...research ended in 2002 with the achievement of the expected objective, i.e., the experimental demonstration that:

1. the application of a negative electric potential to a unidimensional palladium cathode causes a charging increase up to values of the stoichiometric ratio higher than 1, in line with the experiments carried out at LEDA;

2. as the critical value of the stoichiometric ratio is exceeded, a heat quantity exceeding the energy introduced in the electrolytic cell is detected by a calorimeter based on Peltier effect; and,

3. concomitantly with the appearance of this anomalous heat, equivalent to a power of some tens of watts per cubic centimeter, a number of ^4He atoms widely exceeding the environmental background appears in the mass spectrometer. This ^4He anomalous quantity is the “ash” of the nuclear reaction. The ash quantity allows to estimate the total energy produced, which turned out to be of about 300 watts per cubic centimeter of palladium, i.e., lower than the values found at LEDA.

References (1994-2008)

1. L. BERTALOT, F. DE MARCO, A. DE NINNO, R. FELICI, A. LA BARBERA, F. SCARAMUZZI, V. VIOLANTE – *Behavior of a Pd membrane during deuterium electrochemical loading: excess heat production* – Proceedings of the 4th International Conference on Cold Fusion (ICCF4), Lahaina, Maui, Hawaii, USA, December 6-9, 1993, published by the Electric Power Research Institute, Palo Alto, California, USA, Vol. I: Plenary Session Papers, p. 4-1 (1994)
2. L. BERTALOT, F. DE MARCO, A. DE NINNO, R. FELICI, A. LA BARBERA, F. SCARAMUZZI, V. VIOLANTE – *Deuterium charging in palladium by the electrolysis of heavy water: measurement of the lattice parameter* – Proceedings of the 4th International Conference on Cold Fusion (ICCF4), Lahaina, Maui, Hawaii, USA, December 6-9, 1993, published by the Electric Power Research Institute, Palo Alto, California, USA, Vol. 2: Calorimetry and Materials Papers, p. 29-1 (1994). Also published on “Transactions of Fusion Technology, 26, n. 4T, 122 (1994)
3. L. BERTALOT, F. DE MARCO, A. DE NINNO, R. FELICI, A. LA BARBERA, F. SCARAMUZZI, V. VIOLANTE – *Fenomenologia del palladio ad alto caricamento di idrogeno e dei suoi isotopi*. Atti del Convegno Idrogeno e Metalli, a cura dell’Associazione Italiana di Metallurgia – Milano, 109 (1994)
4. F. D’AMATO, A. DE NINNO – *Proposta di esperimento per la rivelazione di tracce di ⁴He in esperimenti di interazione tra Deuterio e Palladio* – ENEA Technical Report RTI-INN(94)-7 (1994)
5. A. DE NINNO, V. VIOLANTE – *Study of Deuterium Charging in Palladium by Electrolysis in Heavy Water* – Fusion Techn. 26, 1304 (1994)
6. A. DE NINNO, V. VIOLANTE, L. BERTALOT, A. LA BARBERA – *Statistical Approach to H-Pd System: Evaluation of Thermodynamic Function of State from Experimental data* – RT ENEA-INN/94/24/Rev 1 (1994)
7. V. VIOLANTE, A. DE NINNO – *Collision between two deuterons in Condensed Matter: Ion Trap Mechanism* – Proceedings of 5th International Conference on Cold Fusion ICCF5 – Monte Carlo, Monaco, April 10-14, 1995, 34 (1995)
8. R. FELICI, L. BERTALOT, A. DE NINNO, A. LA BARBERA, V. VIOLANTE – *In Situ Measurement of the Deuterium (Hydrogen) Charging of a Palladium Electrode During Electrolysis by Energy Dispersive x-ray Radiation* – Rev.Sci Inst 66(5), 3344 (1995)

9. V. VIOLANTE, A. DE NINNO – *Fenomeni di equilibrio e di non-equilibrio correlati alla riproducibilità della Fusione Fredda* – RT ENEA_ERG/FUS/95/034 (1995)
10. A. DE NINNO, A. LA BARBERA, V. VIOLANTE, M. VITTORI – *Conseguenze del gradiente di deformazione prodotto dall'assorbimento dell'idrogeno (e dei suoi isotopi) nel Palladio* – Atti del 26° Congresso Nazionale dell'Associazione Italiana di Metallurgia – Milano 6-8 novembre 1996, 78 (1996)
11. A. DE NINNO, A. LA BARBERA, V. VIOLANTE – *Selection of Palladium Metallurgical Parameters to Achieve very high Loading Ratios, "Progress in New Hydrogen Energy"* – Proceedings of 6th International Conference on Cold Fusion ICCF6, Toya (Hokkaido, Japan) October 13-18, 1996, vol. 1, 221 (1997)
12. F. DE MARCO, A. DE NINNO, A. FRATTOLILLO, A. LA BARBERA, F. SCARAMUZZI, V. VIOLANTE – *Progress Report on the Research Activities on Cold Fusion at ENEA Frascati "Progress in New Hydrogen Energy"* – Proceedings of the Sixth International Conference on Cold Fusion – Toya (Hokkaido, Japan) October 13-18, 1996, vol. 1, 145 (1997)
13. V. VIOLANTE, A. DE NINNO – *Quantum Mechanical Description of a Lattice Ion Trap "Progress in New Hydrogen Energy"* – Proceedings of the 6th International Conference on Cold Fusion ICCF6, Toya (Hokkaido, Japan) October 13-18, 1996, vol. 1, 221 (1997)
14. A. DE NINNO, A. LA BARBERA, V. VIOLANTE – *Consequences of Lattice Expansive Strain gradients on Hydrogen Loading in Palladium* - Phys. Rev. B26, 2417 (1997)
15. A. DE NINNO, A. LA BARBERA, V. VIOLANTE – *Deformations induced by high Loading Ratios in palladium-deuterium Compounds* – Journal of alloys and Compounds, 253-254, 181-184 (1997)
16. V. VIOLANTE, A. DE NINNO – *Lattice Ion Trap: a possible Mechanism Inducing a Strong Approach between two Deuterons in Condensed Matter* – Fus. Tech., vol. 31, 219-227 (1997)
17. A. DE NINNO, M. VITTORI ANTISARI, C. GIANGIORDANO – *Material science studies aimed at improving the reproducibility of the heat excess experiments* – Proceedings of the 7th International Conference on Cold Fusion ICCF7, Vancouver (Canada), April 19-24, 1998, 103 (1998)

18. A. DE NINNO, A. FRATTOLILLO, V. VIOLANTE, F. SCARAMUZZI – *Cold Fusion at ENEA Frascati: Progress Report* – Proceedings of the Seventh International Conference on Cold Fusion ICCF7, Vancouver (Canada), April 19-24, 1998, 108 (1998)
19. A. DE NINNO, A. FRATTOLILLO, A. RIZZO, F. SCARAMUZZI, C. ALESSANDRINI – *A new method aimed at detecting small amounts of helium in a gaseous mixture* – Proceedings of the 8th International Conference on Cold Fusion ICCF8, Lerici (SP), Italia 200, edited by F. Scaramuzzi, published by the Italian Physical Society (SIF), Conference Proceedings n. 70, 29 (2001)
20. M. COLA, E. DEL GIUDICE, A. DE NINNO, G. PREPARATA – *A simple Model of the Cohn-Aharonov Effect in a Peculiar Electrolytic Configuration* - Proceedings of 8th International Conference on Cold Fusion ICCF8, Lerici (SP), May 21-24, 2000, vol. 70 – SIF Bologna, 349 (2000)
21. E. DEL GIUDICE, A. DE NINNO, A. FRATTOLILLO, G. PREPARATA, F. SCARAMUZZI, A. BULFONE, M. COLA, C. GIANNETTI – *The Fleischmann-Pons effect in a novel electrolytic configuration* – Proceedings of the 8th International Conference on Cold Fusion ICCF8, Lerici (SP), May 21-24, 2000, edited by F. Scaramuzzi, published by the Italian Physical Society (SIF), Conference Proceedings n. 70, 47 (2001)
22. E. DEL GIUDICE, A. DE NINNO, A. FRATTOLILLO, G. PREPARATA, F. SCARAMUZZI, A. BULFONE, M. COLA, C. GIANNETTI – *The Fleischmann-Pons effect in a novel electrolytic configuration* - Proceedings of the 8th International Conference on Cold Fusion ICCF8, Lerici (SP) Italy, 2000, edited by F. Scaramuzzi, published by the Italian Physical Society (SIF), Conference Proceedings n. 70, 47 (2001)
23. E. DEL GIUDICE, A. DE NINNO, A. FRATTOLILLO, G. PREPARATA, F. SCARAMUZZI, P. TRIPODI – *Loading palladium with deuterium gas while lowering temperature* - Proceedings of the 8th International Conference on Cold Fusion ICCF8, Lerici (SP) Italy 2000, edited by F. Scaramuzzi, published by the Italian Physical Society (SIF), Conference Proceedings n. 70, 211 (2001)
24. R.G. AGOSTINO, R. FILOSA, V. FORMOSO, G. LIBERTI, A. DE NINNO, F. D'ACAPITO, S. COLONNA – *Electronic Fingerprint of D site occupation in Pd deuteride* - Proceedings of the 8th International Conference on Cold Fusion ICCF8, Lerici (SP) Italy 2000, edited by F. Scaramuzzi, published by the Italian Physical Society (SIF), Conference Proceedings n. 70, 177-180 (2001)

25. X.Z. LI, Y.J. YAN, J. TIAN, M. Y. MEI, Y. DENG, W.Z. YU, G.Y. TANG, D.X. CAO, A. DE NINNO – *Nuclear Transmutation in Pd Deuteride* - Proceedings of the 8th International Conference on Cold Fusion ICCF8, Lerici (SP) Italy 2000, edited by F. Scaramuzzi, published by the Italian Physical Society (SIF), Conference Proceedings n. 70, 123-128 (2001)
26. E. DEL GIUDICE, A. DE NINNO, A. FRATTOLILLO, A. RIZZO – *Production of excess enthalpy and ^4He in Pd cathodes in electrolytic cells* – Proceedings of the 9th International Conference on Cold Fusion – Tsinghua University, Beijing, China, May 19-24, 2002
27. E. DEL GIUDICE, A. DE NINNO, M. FLEISCHMANN, G. MENGOLI – *Time evolution of the electrolytic H loading in Palladium* – Proceedings of the 9th International Conference on Cold Fusion - Tsinghua University, Beijing, China, May 19-24, 2002
28. A. FRATTOLILLO, A. DE NINNO, A. RIZZO – *Experimental Techniques for Detecting small Quantities of the ^4He Gas: Problems and Solutions* - Proceedings of the 9th International Conference on Cold Fusion - Tsinghua University, Beijing, China, May 19-24, 2002
29. A. DE NINNO, A. FRATTOLILLO, A. RIZZO, E. DEL GIUDICE – *Produzione simultanea di eccesso di calore e di ^4He durante l'elettrolisi di acqua pesante su catodo di Palladio* – Workshop TESMI (Tecniche ed Esperimenti in Sistemi Metallo-Idrogeno) – Università di Lecce, Dip. Scienza dei Materiali – Lecce, 6-7 dicembre 2002
30. A. DE NINNO, E. DEL GIUDICE, A. FRATTOLILLO, G. PREPARATA, A. RIZZO – *Experimental Evidence of ^4He Production in a Cold Fusion experiment* – ENEA RT/2002/41/FUS. See also <http://www.lenr-canr.prg/acrobat/DeNinnoAexperiment.pdf>
31. E. DEL GIUDICE, A. DE NINNO, A. FRATTOLILLO – *Are Nuclear Transmutations observed at Low Energies Consequences of QED Coherence?* – Proceedings of the 1st Conference on Cold Fusion ICCF10, Boston, May 2003
32. A. DE NINNO, A. FRATTOLILLO, A. RIZZO, E. DEL GIUDICE – *^4He Detection in a Cold Fusion Experiment* - Proceedings of the 1st Conference on Cold Fusion ICCF10, Boston, May 2003
33. A. DE NINNO, A. FRATTOLILLO, A. RIZZO – *^4He detection in a cold fusion experiment* – Trans. Am. Nucl. Soc., 88, 633-635 (2003)

34. E. DEL GIUDICE, A. DE NINNO, A. FRATTOLILLO, M. FLEISCHMANN – *Coherent Nuclear reactions in Condensed Matter* – Proc. Of the 12 International Conference on Emerging Nuclear Energy System (ICENES 2005), Brussels, August 21-26, 2005 – Ed. SCK-CEN, Mol, Belgium (2005)
35. A. FRATTOLILLO *New simple method for fast and accurate measurement of volumes* -- Rev. of Sci. Instr. – 77 045107 (2006)
36. A. FRATTOLILLO – *Simple automatic device for real time sampling of gas production by a reactor* – Rev. of Sci. Instr., 77 065108 (2006), 77 045107 (2006)
37. A. FRATTOLILLO, A. DE NINNO, A. RIZZO – *Quantitative detection of thiny amounts of helium isotopes in a hydrogen isotope atmosphere using a standard-resolution quadrupole mass spectrometer* - J. Vac. Sci Technol., A25(1) January-February 2007, 75
38. A. DE NINNO, E. DEL GIUDICE, A. FRATTOLILLO – *Evidence of Coherent Nuclear Reactions in Condensed Matter* – American Chemical Society Symposium Series, Low Energy Nuclear Reactions Sourcebook – Ed. Jan Marwan and Steven Krivit Oxford University Press, August 2008

Patents

A. FRATTOLILLO, A. DE NINNO, F. MARINI – Italian Patent and Trademark Office – Record No. BO2004A000517, 2004 “*Dispositivo per la misurazione di precisione di volumi*”

<http://www.uibm-gov.it/uibmdev/Info1.aspx?id=BO2004A000517¶m=0>

A. FRATTOLILLO, A. DE NINNO - Italian Patent and Trademark Office - No. BO2004A000516, 2004 “*Gruppo per il prelievo periodico di campioni da una fase gassosa*”

<http://www.uibm-gov.it/uibmdev/Info1.aspx?id=BO2004A0005167¶m=0>

2.5. Italian Cold Fusion History and International Collaborations

VITTORIO VIOLANTE

ENEA - Frascati

Since early 1996 Vittorio Violante is in charge of the Specific Technologies for Thermonuclear Fusion Division of ENEA's Fusion Department in Frascati. His task implies a reorganization of scientific research, that is why, since 1997, he works autonomously from the research group once headed by Prof. Francesco Scaramuzzi.

Notwithstanding his new commitments, which are expected to last until 2001, Vittorio Violante keeps concerning with the problem of Cold Fusion, which he dedicated to from its very beginning, in Spring 1989.

As it may be inferred from his works published in field literature, his scientific contribution is focused essentially on the theoretical aspects related to material science and to the possible interaction mechanisms among deuterium nuclei in the palladium lattice.

In this period, he keeps collaborating with prestigious US Institutes and, in particular, with SRI International and the University of Illinois.

His investigations in the field of material science had already started in the last period of the work he carried out with the group co-ordinated by Prof. Scaramuzzi. The results of this work were presented in the ICCF6 Conference in Toya (Japan) in October 1996.

Since the beginning of the Nineties, thanks to the studies by McKubre and Kunimatzu, it was discovered that heat production was a threshold phenomenon. In other words, reaching a certain value of deuterium concentration in palladium was necessary for the phenomenon to be observed with a certain probability. This experimental observation draw the attention on material science issues. The problem to be tackled was: Can certain palladium characteristics be an obstacle for the diffusion of deuterium in the lattice? Moreover, which are these characteristics and how do they affect the diffusive process?

An accurate study of transport mechanisms allowed to explain the failed achievement of deuterium concentration threshold as the effect of the stress field on the increase in the chemical potential of deuterium in palladium.

This approach permitted to determine a specific metallurgic structure able to minimize the stress field during the diffusion process of deuterium. A technology producing palladium with these characteristics was developed and later patented by ENEA.

Such studies turned into experimental activities only beginning from 2001. In that period, the Research Laboratory of Energetics USA, which was located in Israel and had started an experimental activity on cold fusion, contacted the ENEA Technologies Division as it was interested to use palladium cathodes realized through the technique set up by Violante.

Almost at the same time, also SRI contacted the same ENEA Division for analogous activities concerning cold fusion. Thanks to the support deriving from the two contracts and by means of some instrument used in the Division the basics were set up to begin experimental tests on materials again.

A research programme was started with the target of obtaining a type of material able to detect the phenomenon of power excess production with a high signal/noise ratio. Over years, two post graduate students – Luigi Capobianco first, and later Emanuele Castagna, the latter as a final year student first and as a post graduate student later – collaborated along with several final year students.

Also La Sapienza University of Rome started taking part in the activities, in particular Prof. Sabilia from the Department of Energetics and Prof. Del Prete from the Department of Mechanical Engineering.

The first two years of work not only permitted to develop materials able to assure the achievement of deuterium concentration threshold with a reproducibility higher than 90%, but also to observe the phenomenon in 20% of experiments and with high signals. Moreover, transferred reproducibility began to be considered since also Energetics' Laboratory achieved similar results, using cathodes produced by ENEA.

The results achieved at ENEA by Violante and those attained by Energetics researchers were presented at the 10th International Conference on Cold Fusion held in Boston in August 2003.

These and other results presented in Boston induced some US researchers to ask DoE to revise the matter. For this reason, in August 2004, the DoE invited six experts – five from the United States and one from Italy (Vittorio Violante) to a Panel in the presence of about twenty referees.

In Autumn 2005, in agreement with DoE's opinion, a study began in the United States with the financial support by the government and SRI was charged with reproducing the same results as Energetics did using palladium cathodes produced by ENEA.

In the same period, the Italian Ministry for Economic Development (MSE, former MAP) decided to finance a research project entitled "Generazione di Eccesso di Potenza in Metalli Deuterati."¹ The project was assigned to ENEA and Vittorio Violante was charged with its coordination. From January 2006, the Italian and the US projects were carried out in parallel with the strongest interaction. SRI bought electrodes from ENEA, which were produced and tested at the Frascati Research Centre.

The Ministry's support created the conditions to carry out studies on a larger scale in the field of material science including those aspects related to surface physics.

The arrival of new professional resources was of the highest importance. Dr Francesca Sarto, Dr. Stefano Lecci and Mr. Mirko Sansovini joined the research group initially consisting only of VV and the postgraduate student, Emanuele Castagna.

In this period an additional collaboration began between the ENEA team coordinated by VV and the Naval Research Laboratory of Washington DC. The activity shared by the two Institutes basically concerned material science aspects of the palladium-hydrogen system. The economic support by the London's Office of Naval Research made it possible to plan and realize an experiment, to be conducted at the Brookhaven National Laboratory in Long Island based on the use of the synchrotron light facility of such laboratory. An electrochemical cell, designed and set up in collaboration with NRL, permitted to perform experiments of X-ray diffraction on ENEA cathodes, to study the palladium-hydrogen (deuterium) system in the unexplored $H(D)/Pd \sim 1$ region. The experiment concluded successfully.

A positive outcome was also obtained as to cold fusion research: during 2006, ENEA achieved over 60% of reproducibility in power excess production and SRI reached 75%.

The US revision programme envisaged two phases: passing to the second phase depended on getting through the first one.

¹ *Translator's note:* Power Excess Production in Deuterated Metals

The commission of government referees established as a valid target for getting through the first phase, the achievement, at least in one experiment, of a power excess equivalent to 100% of the input power. This target was amply reached in three experiments. ENEA achieved power excess events with output power higher than 500% of the input power.

In 2007 the USA approved the passage to the second phase, which saw the participation of the Naval Research Laboratory of Washington DC. In Italy, in December 2007, the ENEA-MSE project concluded with the achievement of the targets expected by the research programme.

Fig. 1 shows the typical behaviour in an experiment performed with light water: as the calorimeter exceeds the thermal transient the output power curve overlap the input power curve and never exceeds it.

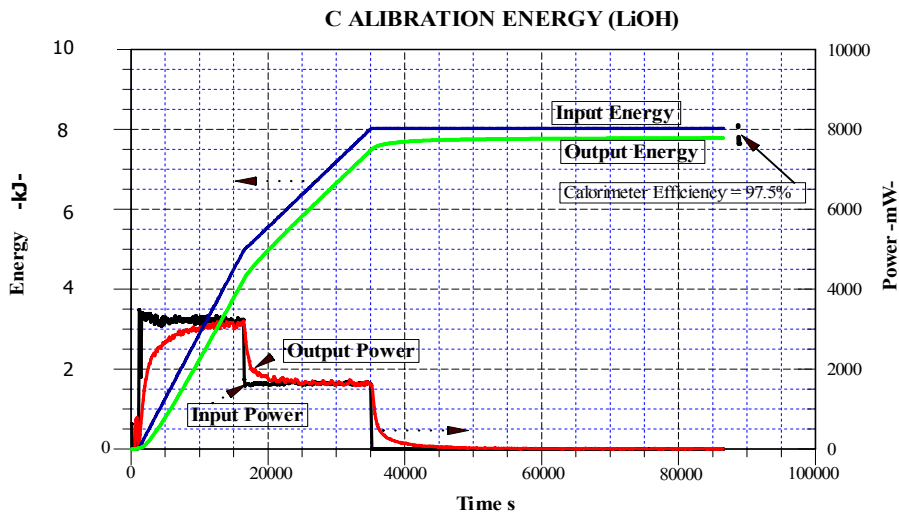

Fig. 1- Input and output power and energy during an experiment With hydrogen. Efficiency = 97.5%.

Fig. 2 shows a 500% power excess obtained with heavy water. This result belongs to the series of excess events observed during the experiments performed within the project supported by MSE.

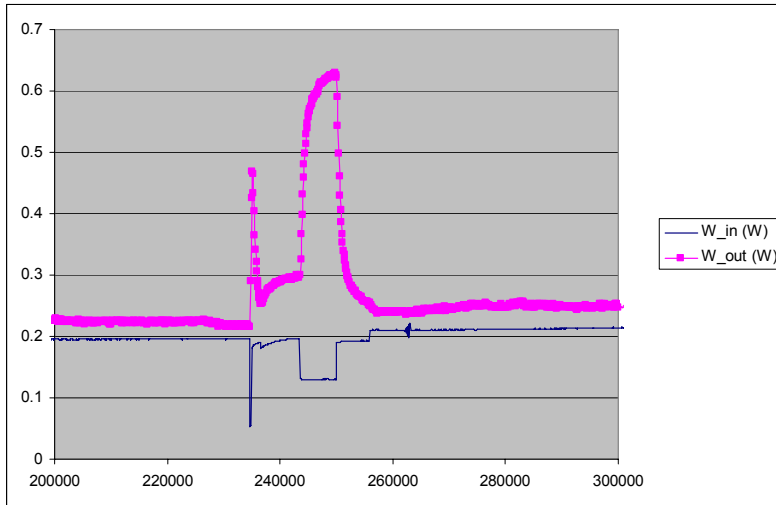

Fig. 2 – Power excess in L17 experiment, input and output (upper curve) power. During power excess production, the output power is five times higher than the input power

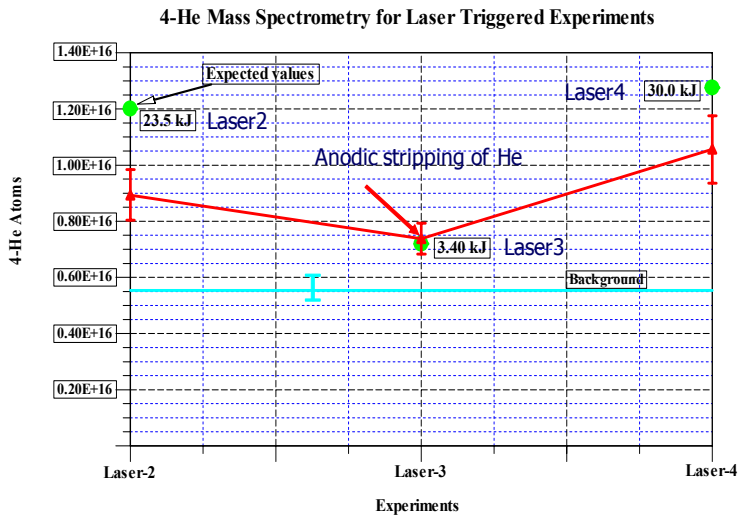

Fig. 3 – The expected amount of increasing of ${}^4\text{He}$ is in accordance with the energy gain by assuming a $\text{D} + \text{D} = {}^4\text{He} + 24 \text{ MeV}$ reaction

Fig. 3 shows the results of preliminary measurements of ${}^4\text{He}$, a nuclear ash of the $(\text{D} + \text{D} \rightarrow {}^4\text{He} + \text{heat})$ fusion reaction which power excess production is ascribed to.

The measurements were carried out by using a JEOL GCMate-magnet mass spectrometer with a resolution limit of 0.0001 amu.

Circles show the expected value of helium concentration estimated according to the energy gains measured in the three experiments (Laser2, Laser3, Laser4) which the figure refers to.

The increase in helium concentration in the electrolytic cell is proportional to the energy gain obtained in the three experiments and can be compared with the background, represented by the horizontal line. The background was obtained through approximately seventy measurements carried out on samples from the room's air, gas samples taken from electrochemical cells tested with both light and heavy water and that did not produce any power excess.

Closed cells were used equipped with a catalytic recombiner, with high vacuum technology and air-tight, so that they had an initial helium content equivalent to that of air (5.2 ppm, background line). Therefore, in these experiments, all helium measurements refer to increases in helium concentration compared to the background. That is the reason why the problem of a possible contamination from the outside due to helium permeation does not arise. If any, the problem is quite the opposite: to avoid that helium permeates outside, because the partial pressure inside the cell is higher than the pressure outside it.

In the two experiments, Laser2 and Laser4, it can be observed that even if the measured value is close to the expected one and is proportional to the energy gain, the measurement gives an helium amount lower than the expected value. This does not happen in the case of Laser3 experiment.

This behaviour is due to the fact that a part of the produced helium remains in the electrode (presumably in the first microns of the material). In Laser3 experiment an anodic stripping was carried out by switching polarity, thus allowing to extract about all the helium present in the palladium cathode. This behaviour is exactly the same, also in percentage values, as that observed at SRI International Institute of California.

Fig. 4 shows the power excess progress during Laser4 experiment.

Excess of Energy and Power in Laser4 Experiment

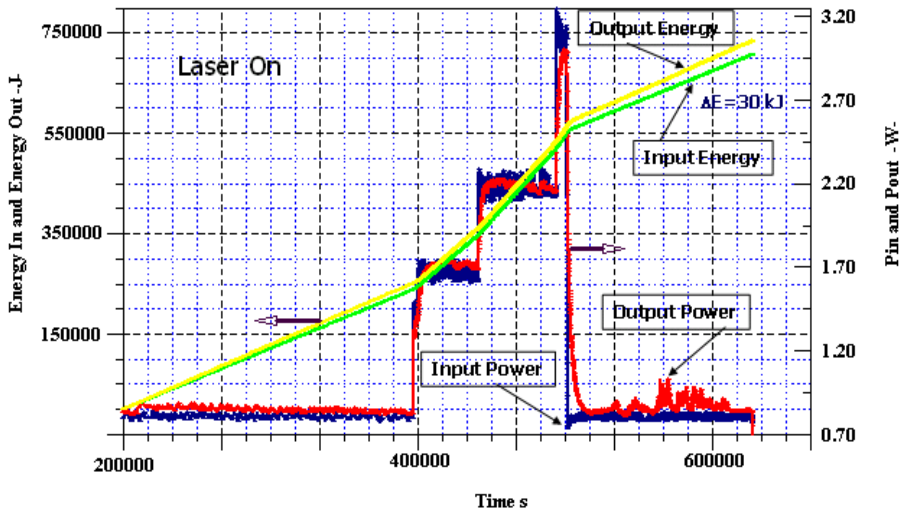

Fig. 4 – Input/Output Power and Energy trend during Laser4 experiment

Bibliography

- 1) L. BERTALOT, V. VIOLANTE ET AL., *Analysis of Tritium and Heat Excess in Electrochemical Cells with Pd Cathodes*. Proceedings of the II Annual Conference in Cold Fusion, Como (Italy), June 29 – July 4, 1991, 3-7 (1991).
- 2) L. BERTALOT, F. SCARAMUZZI, V. VIOLANTE ET AL., *Study Deuterium Charging in Palladium by the Electrolysis of Heavy Water: Search for Heat Excess and Nuclear Ashes*. Proceedings of the Third International Conference on Cold Fusion, Nagoya (Japan), October 21-25, 1992, 365-371 (1992).
- 3) L. BERTALOT, V. VIOLANTE ET AL., *Fenomenologia del Palladio ad Alto Caricamento di Idrogeno e dei suoi Isotopi*, Atti del Convegno: "Idrogeno e Metalli", Milano 26-27 maggio 1994, 109-117 (1994).
- 4) L. BERTALOT, V. VIOLANTE ET AL., *Deuterium Charging in Palladium by the Electrolysis of Heavy Water: Measurement of the Lattice Parameter*. Transactions of Fusion Technology, 27(1994) 122-125.
- 5) A. DE NINNO, V. VIOLANTE, *Study of Deuterium Charging in Palladium by Electrolysis of Heavy Water*. Fusion Technology 26(1994) 1304-1310.
- 6) R. FELICI, V. VIOLANTE ET AL., *In-situ Measurement of the Deuterium (Hydrogen) Charging of a Palladium Electrode During Electrolysis by Energy Dispersive X-Ray Diffraction*, Review of Scientific Instruments, 66(5) (1995) 3344-3348.

- 7) L. BERTALOT, V. VIOLANTE ET AL. *Power Excess Production in Electrolysis Experiments at ENEA Frascati*. Proc. Fifth International Conference on Cold Fusion, MonteCarlo, Monaco April 9-13, 1995 - 34-40.
- 8) V. VIOLANTE, A. DE NINNO, *Collision Between Two Deuterons in Condensed Matter: Ion Trap Mechanism*. Proc. Fifth International Conference on Cold Fusion, MonteCarlo, Monaco April 9-13, 1995 355-359.
- 9) V. VIOLANTE, A. DE NINNO, *Lattice Ion Trap: A Possible Mechanism Inducing a Strong Approach Between Two Deuterons in Condensed Matter*. Fusion Technology 31 (1997) 219-227.
- 10) L. BERTALOT, V. VIOLANTE ET AL. *Study of Deuterium Charging in Palladium by the Electrolysis of Heavy Water: Heat Excess Production*. Il Nuovo Cimento, 15, N.11 (1993) 1435-1443.
- 11) F. DE MARCO, V. VIOLANTE ET AL. *Progress Report on the Research Activities on Cold Fusion at ENEA Frascati*. Proc. VI International Conference on Cold Fusion, Vol. 1, (145-153). Toya (Japan) October 13-18, 1996.
- 12) A. DE NINNO, A. LA BARBERA, V. VIOLANTE, *Selection of Palladium Metallurgical Parameters to Achieve Very High Loading Ratios*. Proc. VI International Conference on Cold Fusion, Vol. 1, (192-197). Toya (Japan) October 13-18, 1996.
- 13) V. VIOLANTE, ET AL. *Quantum Mechanical Description of a Lattice Ion Trap: Deuteron Approaching Mechanism in Condensed Matter*. Proc. VI International Conference on Cold Fusion, Vol. 1, (221-227). Toya (Japan) October 13-18, 1996.
- 14) A. DE NINNO, A. LA BARBERA, V. VIOLANTE, *Deformations Induced by High Loading Ratios in Palladium-Deuterium Compounds*, J. Of Alloys and Compounds, 253-254 (1997) 181-184.
- 15) A. DE NINNO, A. LA BARBERA, V. VIOLANTE, *Consequences of Lattice Expansive Strain Gradients on Hydrogen Loading in Palladium*. Phys. Rev. B, Vol. 56, N. 5 (1997) 2417-2420.
- 16) V. VIOLANTE, A. TORRE, G. DATTOLI, *Lattice Ion Trap: Classical and Quantum Description of a Possible Collision Mechanism for Deuterons in Metal Lattices*. Fusion Technology 34(1998) 156.
- 17) V. VIOLANTE, *Lattice Ion Trap Confinement for Deuterons and Protons: Possible Interactions in Condensed Matter*. Fusion Technology 35 (1999) 361-368.

- 18) M. BERTOLOTTI, G.L. LIAKHOU, R. LI VOTI, S. PAOLONI, C. SIBILIA, V. VIOLANTE., *Non Destructive Evaluation of the Thermal Properties of Palladium-Hydrogen Compounds by Photothermal Technique*. Proceedings International Conference on Cold Fusion. Vancouver (Canada) April 19-24, 1998, 22-26.
- 19) V. VIOLANTE, *Extended Analysis of the Lattice Ion Trap as Possible Collision Mechanism Between Nucleus in Condensed Matter*, Proceedings International Conference on Cold Fusion. Vancouver (Canada) April 19-24, 1998, 403-408.
- 20) A. DE NINNO, A. FRATTOLILLO, V. VIOLANTE, F. DE MARCO, F. SCARAMUZZI, *Cold Fusion at ENEA Frascati: Progress Report*, Proceedings International Conference on Cold Fusion. Vancouver (Canada) April 19-24, 1998, 108-112.
- 21) V. VIOLANTE, *Lattice Confinement: a Possible Mechanism Producing "collisions" between Particles in Condensed Matter*. Proceedings of the III Asti Workshop on Anomalies in Hydrogen/Deuterium Loaded Metals. Rocca d'Arazzo (Italy) November 27-30, 1997. Edited by W.J.M.F. Collis pg.89-96.
- 22) G. SELVAGGI, V. VIOLANTE, G.H. MILEY, *Coherent Lattice Accelerator Inter-ionic Reactions Enhancer*. Proceedings Centennial Meeting of the American Physical Society Atalanta (USA) March 20-26, 1999. Vol. 44 No.1 Part II (1277).
- 23) V. VIOLANTE, D. DI GIOACCHINO, P. TRIPODI, M. MCKUBRE, F. TANZELLA, *Numerical Calculation of Excess Heat Production in the MATRIX Experiment*, 4th Asti Workshop on Anomalies in Hydrogen/deuterium Loaded Metals. Rocca d'Arazzo (Italy) October 22-24, 1999.
- 24) V. VIOLANTE, G.H. MILEY, G. SELVAGGI, *3-D Dynamics of Hydrogen Isotopes within a Metal Lattice*. 4th Asti Workshop on Anomalies in Hydrogen/deuterium Loaded Metals. Rocca d'Arazzo (Italy) October 22-24, 1999.
- 25) V. VIOLANTE, C. SIBILIA, D. DI GIOACCHINO, M. MC KUBRE, F. TANZELLA, *Hydrogen Isotopes Interaction Dynamics in Palladium Lattice*. VIII International Conference on Cold Fusion, Lerici May 2000, Ed. Italian Physical Soc. Vol. 70 (2000) 409-417.
- 26) M. MCKUBRE, V. VIOLANTE ET AL. *Finite Element Modeling of the Transient Calorimetric Behavior of the MATRIX Experimental Apparatus: ⁴He and Excess of Power Production Correlation through Numerical*

Results. VIII International Conference on Cold Fusion, Lerici May 2000, Ed. Italian Physical Soc. Vol. 70 (2000) 23-27.

27) V. VIOLANTE, L. CAPOBIANCO, *Metallurgical effects on the dynamic of Hydrogen loading in Pd*, Proceedings ICCF-9, Beijing (China) May 2002

28) P. TRIPODI, M.C.H. MCKUBRE, F.L. TANZELLA, P.A. HONNOR, D. DI GIOACCHINO, F. CELANI, V. VIOLANTE, *Temperature coefficient of resistivity at composition approaching PdH*. Physics Letter A 276 (2000) 1-5.

29) V. VIOLANTE, G.H. MILEY ET AL., *Recent Results from Collaborative Research at ENEA-Frascati on Reaction Phenomena in Solids*, Transac. American Nuclear Soc., 83, 361(2000)

30) V. VIOLANTE, P. TRIPODI, C. LOMBARDI, *Le Conoscenze Attuali sulla Fusione Fredda*, La Termotecnica, March (2001) 67-72.

31) V. VIOLANTE, A. TORRE, G.H. MILEY, G. SELVAGGI, *Three Dimensional Analysis of the Lattice Confinement Effect on Ions Dynamics in Condensed Matter and Lattice Effect on the D-D Nuclear Reaction Channel*. Fusion Technology 39 (2001) 266-281.

32) M. MCKUBRE, V. VIOLANTE ET AL. *Progress Towards Replication*, Proceedings ICCF-9, Beijing (China) May 2002.

33) V. VIOLANTE, M. MCKUBRE ET AL, *X-Ray Emission During Electrolysis of Light Water on Palladium and Nickel Thin Films*, Proceedings ICCF-9, Beijing (China) May 2002.

34) V. VIOLANTE ET AL. *Introduzione ai Processi Nucleari a Bassa Energia nella Materia Condensata*, Energia Ambiente Innovazione 2/03, pg 38.

35) V. VIOLANTE ET AL. *Non Equilibrio e Fenomeni di Trasporto che Controllano la Riproducibilità della Generazione di Eccesso di Potenza in Metalli Deuterati*, Energia Ambiente Innovazione 1/04, pg 46.

36) V. VIOLANTE, M. APICELLA, L. CAPOBIANCO, F. SARTO, C. SIBILIA, A. ROSADA, E. SANTORO, M. MCKUBRE, F. TANZELLA, *Search for nuclear ashes in electrochemical experiments*, Scientific Press Proc. ICCF10, Boston, August 2003, 405.

37) V. VIOLANTE, F. SARTO, C. SIBILIA, E. CASTAGNA, S. PAOLONI, *Analysis of Ni Hydride thin film after surface plasmons generation by laser technique*. Scientific Press Proc. ICCF10, Boston, August 2003, 421.

38) V. VIOLANTE, C. SIBILIA ET AL. *Study of lattice potentials on low energy nuclear processes in condensed matter*, Scientific Press Proc. ICCF10, Boston, August 2003, 667.

- 39) M. APICELLA, E. CASTAGNA, G. HUBLER, M. MCKUBRE, F. SARTO, C. SIBILIA, A. ROSADA, E. SANTORO, F. TANZELLA, V. VIOLANTE *Progress on the Study of Isotopic Composition in Metallic Thin Films Undergone to Electrochemical Loading of Hydrogen*, Proc. ICCF12 Yokohama Nov-2005, 264.
- 40) M. APICELLA, E. CASTAGNA, L. CAPOBIANCO, L. D'AULERIO, G. MAZZITELLI, M. MCKUBRE, F. SARTO, C. SIBILIA, A. ROSADA, E. SANTORO, F. TANZELLA, V. VIOLANTE, *Some Recent Results at ENEA*, Proc. ICCF12 Yokohama Nov-2005, 117.
- 41) E. CASTAGNA, V. VIOLANTE, C. SIBILIA, S. PAOLONI, F. SARTO *Surface Plasmons and Low Energy Nuclear Reactions Triggering*, Proc. ICCF12 Yokohama Nov-2005, 156.
- 42) L. D'AULERIO, V. VIOLANTE, E. CASTAGNA, R. FIORE, R. DEL PRETE, L. CAPOBIANCO, F. TANZELLA, M. MCKUBRE, *Thermal Analysis of Calorimetric Systems*, Proc. ICCF12 Yokohama Nov-2005, 145.
- 43) V. VIOLANTE, S. MORETTI, M. BERTOLOTTI, E. CASTAGNA, C. SIBILIA, F. SARTO, M. MCKUBRE, F. TANZELLA, I. DARDIK, S. LESIN, T. ZILOV, *Progress in Excess of Power Experiments with Electrochemical Loading of Deuterium in Palladium*. Proceedings XII, International Conference on Cold Fusion, Yokohama (J), Nov 2005, 55.
- 44) V. VIOLANTE, F. SARTO, E. CASTAGNA, C. SIBILIA, M. BERTOLOTTI, R. LI VOTI, G. LEHU, M. MCKUBRE, F. TANZELLA, G. HUBLER, D. KNIES, T. ZILOV, AND I. DARDIK, *Calorimetric Results of ENEA Cooperative Experiments*, Proc. XIII International Conference on Cold Fusion, Sochi, June 2007.
- 45) E. CASTAGNA, V. VIOLANTE, C. SIBILIA, F. SARTO, *Surface Plasmons Excitation on Metal and on Metal Hydride Surfaces*, Proc. XIII International Conference on Cold Fusion Sochi, June 2007.
- 46) M.C.H. MCKUBRE, V. VIOLANTE ET AL. *Replication of Condensed Matter Heat Production*, accepted for publication by: American Chemical Society.

Patent

V. VIOLANTE ET AL. *Procedimento metallurgico per aumentare la capacità di assorbimento dell'idrogeno da parte di alcuni metalli come palladio, nichel e loro leghe*. RM2004-000473

2.6. Gas Loading at Low Temperatures

FRANCESCO. SCARAMUZZI

INFN National Laboratories, Frascati

Ever since the '60s deuterium absorption in palladium were studied in experiments was a palladium sample was put in contact with gas-phase deuterium. In particular, the dependence of absorption on pressure and temperature was studied. The graphic reported in Fig. 1 shows the results achieved by a group of German researchers in 1964: the x axis reports the absorption measured by the atomic ratio D/Pd, the y axis reports pressure; different curves relating to different temperatures are shown.

It can be observed that the quantity of deuterium absorbed at equilibrium increases with increasing pressure and decreasing temperature. As it is known that very high pressures are necessary to achieve high values of absorption (possibly close to 1) at room temperature, it was decided to opt for gas loading at low temperature.

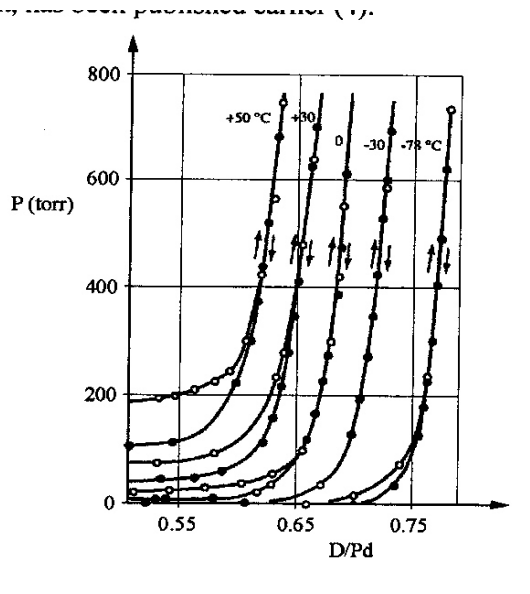

Fig. 1 - The absorption of gas-phase deuterium in palladium, as a function of pressure and temperature (1)

Within the framework of the activities promoted on the initiative of Giuliano Preparata at ENEA research centre in Frascati, at the end of 1999 an experiment was started aiming at achieving such target. It was aimed at measuring the loading along a set of isotherms, as a function of pressure. From the cryogenic point of view, it was decided to cool the system by using a closed-circuit gas refrigerator allowing to assure any temperature between room temperature and about 20 K.

The first activities were dedicated to setting up the cryogenic device. Moreover, a practical and sensitive calorimeter was realized, based on the use of a thermoregulator. These first results were reported at the ICCF8 Conference in Lerici, in 2000, and published on the Conference Proceedings (2).

Later on this research was carried on only by me myself, who succeeded in performing a first “demonstration” experiment in Spring 2002. The results were rather exciting: in fact, I achieved a loading value of about 1 at a 150 K temperature and at pressure a little lower than 1 bar. Fig. 2 shows the results achieved in that experiment with 3 pressure values.

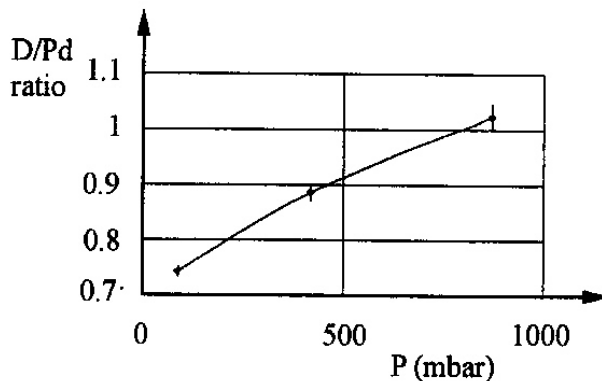

Fig. 2 - The absorption (D/Pd ratio) of gas-phase deuterium in palladium at 150 K, as a function of pressure, measured in the experiment carried out at ENEA Frascati Centre in 2002

These results were presented at a *Workshop* organized by the University of Lecce in December 2002. They appeared in the *Workshop Acts* (3), and were later published on the *Journal of Alloys and Compounds* (4).

Since it was not possible to carry on this line of research in the ENEA Frascati Centre, I proposed it to be continued at INFN National Laboratories in Frascati and, at present, the setting up of an equipment allowing for the measurements to start again is next to be completed.

References

1. E. WICKE, G.H. NERNST, *Ber. Bunsenges. Phys. Chem.* 68 (1964) 224.
2. E. DEL GIUDICE, A. DE NINNO, A. FRATTOLILLO, G. PREPARATA, F. SCARAMUZZI, P. TRIPODI, *Proceedings of the "8th International Conference on Cold Fusion"*, Lerici (SP) Italy, May 21-26, 2000, Editrice Compositori Bologna, Conference Proceedings no. 70 by Società Italiana di Fisica (2001) 211.
3. F. SCARAMUZZI, *Atti del Workshop TESMI (Tecniche ed Esperimenti in Sistemi Metallo-Idrogeno)*, Università di Lecce, Lecce 6-7 Dic. 2002.
4. F. SCARAMUZZI, *Journal of Alloys and Compounds*, 385 (2004) 19.

CHAPTER 3

RESEARCH IN CNR LABORATORIES

(by **SERGIO MARTELLUCCI**)

3.1. Introduction

Research on Cold Fusion, both experimental and theoretical, started in Italy since the publication of the Fleischmann-Pons experiment in March 1989. Research activities in this field were very intense, or rather hectic in many Laboratories and Institutes which were part of both the CNR Chemical Science and Physical Science Committees.

Conversely, nowadays it is possible to affirm that most CNR activities have remarkably reduced, even because most of the researchers very active in the Nineties have retired.

Obtaining contributions by CNR researchers or former researchers was extremely difficult for the Italian Editorial Board. As an exemplification of activities in this field, both experimental and theoretical, in this Chapter only some abstracts of articles by CNR researchers are reported edited by Francesco Scaramuzzi and by me myself. Therefore, the reader who might be interested in getting more information may refer to the specific Conference Proceedings amply mentioned in the other Chapters. First of all, Vol. 24 of "Understanding Cold Fusion Phenomena" Conference Proceedings, published by SIF, edited by R.A. Ricci, F. De Marco and E. Sindoni, (Varenna, September 15-16, 1989), whose Introduction by the SIF President, Renato Angelo Ricci, is reproduced in the following Chapter 4.

3.2. Measurement of Lattice Parameters During Deuterium Charging in Palladium

Collaboration between the CNR Institute for the Physics of Matter in Frascati and the ENEA Frascati Group

(by **FRANCESCO SCARAMUZZI**)

Mention must be made of the measurement of cell parameters in real time, during the loading of palladium by electrolysis. This research produced very promising results and was carried out within a collaboration between the CNR Institute for the Structure of Matter in Frascati and the ENEA Frascati Group.

These results were presented at the “4th International Conference on Cold Fusion”, held in Maui, Hawaii (USA) in December 1993 and were published on that Conference Proceedings (1). Later on, an article was published on the “Review of Scientific Instruments” (2). The Abstracts of the two contributions are quoted here as follows.

Abstract of contribution 1

DEUTERIUM CHARGING IN PALLADIUM BY THE ELECTROLYSIS OF HEAVY WATER: MEASUREMENT OF THE LATTICE PARAMETER

LUCIANO BERTALOT, FRANCESCO DE MARCO, VITTORIO VIOLANTE

Ass. EURATOM-ENEA on Fusion, CR Frascati

ANTONELLA DE NINNO, FRANCESCO SCARAMUZZI

ENEA, INN Dept., Applied Physics Division, CR Frascati

AURELIO LA BARBERA

ENEA – INN-NUMA Dept., CR Casaccia

ROBERTO FELICI

Institute for Structure of Matter, CNR Frascati

We report on X-ray diffraction measurements performed during the charging of a palladium cathode with deuterium by the electrolysis of a LiOD-heavy water solution to determine the lattice parameter. In this way we are able to study the dynamics of the process and to determine the D/Pd final ratio of the sample. Up to now we have studied three samples, which have shown very different behaviours. The estimated bulk deuterium concentration was then checked by degassing the cathode in a known volume.

Abstract of contribution 2

IN SITU MEASUREMENT OF THE DEUTERIUM (HYDROGEN) CHARGING OF A PALLADIUM ELECTRODE DURING ELECTROLYSIS BY ENERGY DISPERSIVE X-RAY DIFFRACTION

ROBERTO FELICI

CNR Institute for Structure of Matter, Frascati

LUCIANO BERTALOT, ANTONELLA DE NINNO,

AURELIO LA BARBERA E VITTORIO VIOLANTE

ENEA-Frascati

A method to determine the concentration of deuterium inside a palladium cathode during the electrolysis of LiOD-heavy water solution is described. This method is based on the measurement of the host metal lattice parameter which is linearly related to the concentration in a wide range. A hard-x-ray beam which is able to cross two glass walls and few centimetres of water solutions without suffering a strong attenuation has been used. The measurement of the lattice parameter is performed in situ, during the electrolysis, by using energy dispersive x-ray diffraction. The sample volume illuminated by the x-ray beam is limited to a small region close to the surface and depends on the incident photon energy. In principle, this allows one to study the dynamics of the charging process and to determine the concentration profile in the range from few up to tens of micrometers. The deuterium concentration, determined by this method, was then checked by degassing the cathode in a known volume and was always found in a very good agreement, showing that the charging was uniform for the whole sample.

References

1. L. BERTALOT, F. DE MARCO, A. DE NINNO, R. FELICI, A. LA BARBERA, F. SCARAMUZZI, V. VIOLANTE, *Deuterium charging in palladium by the electrolysis of heavy water: measurement of the lattice parameter*, Proceedings of the 4th International Conference on Cold Fusion (ICCF4), Lahaina, Maui, Hawaii, USA, December 6-9, 1993, published by Electric Power Research Institute, Palo Alto, California, USA, Vol. 2: Calorimetry and Materials Papers, 29-1 (1994). Also published on "Transactions of Fusion Technology", 26, no.4T, 122 (1994)
2. R. FELICI, L. BERTALOT, A. DE NINNO, A. LA BARBERA, V. VIOLANTE, *In situ measurement of the deuterium (hydrogen) charging of a palladium electrode during electrolysis by energy dispersive x-ray radiation*, Rev. Sci. Instrum., 66, 3344 (1995)

3.3. A Possible Explanation of Cold Nuclear Fusion Process

(by S. MARTELLUCCI)

Several theories have been studied also in the CNR Research Laboratories in order to explain the Cold Fusion phenomenon. In the following chapter, the Bressani-Del Giudice-Preparata theory will be referred to as one of the most important ever developed since 1989.

As far as CNR contribution is concerned mention is made, as an example, of the following work presented at the Varenna Conference, organized by SIF in September 1989, edited by R.A. Ricci, F. De Marco and E. Sindoni, and published in its first shape on *Il Nuovo Cimento*, Vol. 11D no. 6, 927, June 1989.

The Abstract of the contribution published on *Il Nuovo Cimento* is quoted here below.

Abstract

SCREENING EFFECT OF IMPURITIES IN METALS: A POSSIBLE EXPLANATION OF THE PROCESS OF COLD NUCLEAR FUSION

MORENO VASELLI, VINCENZO PALLESCHI, GIUSEPPE SALVETTI E

DARM PAL SINGH

CNR, Institute of Atomic and Molecular Physics

MOHAMED ABDEL HARITH

Cairo, University, Faculty of Science, Department of Physics

The screening length of the deuterium ion by surrounding electrons in a palladium metal lattice, as estimated using two approaches - viz. the Thomas-Fermi screening theory and the Debye screening theory for plasmas in metal - is found to be less than the interatomic separation of ordinary hydrogen molecules. This has important implications for the possibility of cold nuclear fusion at room temperature, since slight fluctuations in equilibrium conditions may drive the deuterons to fuse together. The relative magnitudes of screening length for the cold nuclear fusion regime and classical hot nuclear regimes (inertial and magnetic confinement) reveal that in the former a comparatively smaller amount of energy is needed to overcome the repulsive Coulomb barrier between two deuterium ions.

CHAPTER 4

RESEARCH at INFN (National Laboratories and Sections)

*(by **SERGIO MARTELLUCCI**)*

4.1. Introduction

This chapter reproduces the contributions that researchers operating both in the INFN National Laboratories and in its Sections – hosted by many Italian Universities – sent to the Italian Editorial Board. Besides the scientific interest proved by the INFN researchers since the very beginning, they also document the continuity they have always maintained so far with great success in the field of Cold Fusion.

In next paragraph 4.2., “Understanding Cold Fusion Phenomena”, the Introduction by Renato Angelo Ricci – from the INFN National Laboratories in Legnaro (PD) – already mentioned in the Introduction to previous chapter 3, is reported. In such introduction the reader will find reference to the first chapter "Overview of Cold Fusion Results" by F. De Marco, who unfortunately passed away last year, when he was organizing an ENEA-INFN joint experiment at the INFN Gran Sasso Laboratories, in order to demonstrate the role played in the Cold Fusion phenomenon by a possible nuclear fusion with neutrino production.

In the following contributions particular mention is made of the activities carried out by the Catania Group – which hosted the last International Conference on Cold Fusion in 2007 – and of the international representative charge within the Executive Committee of Condensed Matter Nuclear Science, currently held by Francesco Celani.

4.2. Understanding Cold Fusion Phenomena¹

RENATO ANGELO RICCI, FRANCESCO DE MARCO E ELIO SINDONI

*INFN National Laboratories – Legnaro, Padua
ENEA – Frascati, Milan University – Physics Department*

Introduction

“Understanding cold fusion phenomena” could appear a quite provocative title for the workshop held at Villa Monastero in Varenna on September 15-16, 1989. In fact the opportunity offered by the Italian Physical Society, the International School of Plasma Physics and the European Physical Society to a large scientific community did concern the presentation and discussion of the most advanced attempts and results, positive and negative, on a variety of phenomena dealing or not with “cold fusion” that are not yet understood at all.

130 scientists, representing a large number of Laboratories and Institutions around the World, had the possibility to meet once more, or for the first time, in a quiet and pleasant corner of the Lake of Como, far away from the heat of the previous debates and from the chaotic noise of the mass media. Such a noise has in fact increased the obvious difficulties in extracting the real signals arising from scientific reports.

As indicated in the overview of De Marco, one of the major problems in this field has been that “only a part of the information appears in scientific publications or is directly controllable”.

Nevertheless, the main success of the various meetings held after March '89 has been to compare the immediate experimental replies of the “pioneering work” of the University of Utah and of the Brigham Young University, in order to analyse in a more and more scientific way the reliability and reproducibility of such experiments.

Along this line, one of the merits of the Varenna workshop was to put all the reports and presentations on the same ground, whatever the outcome could be, keeping always in mind that every dispute should become a scientific controversy.

¹ Società Italiana di Fisica– *Atti di Conferenze, Vol. 24*, a cura di R.A. Ricci, F. De Marco e E. Sindoni, Varenna, 15-16 settembre 1989.

This scope has been achieved and only the absence of M. Fleischmann, S. Jones and M. Gai, who were unable to attend the meeting in spite of their personal interest, was a serious limitation. Nevertheless, the participation of the very qualified representatives of the most involved groups and laboratories (Harwell, Texas, PSI, Legnaro, Frascati (ENEA and INFN), Milano, CEC, Ispra, Berlin, Madrid, Roma-Sanità, CNR, Stockholm, Fribourg, etc) has been such that the various aspects of the problem could be talked in many details without any bias.

A possible assessment of the scientific issues of the observed phenomena has been summarized as follows:

Reality of the experimental findings

i.e. new phenomena, nuclear or not nuclear?

Fusion processes or not: spurious effects (other than physical: chemical, mechanical, background and/or micro phonic phenomena...).

No effects at all (out of natural noise).

Heat and Radiation

- *Heat measurements* (calorimetry); positive results (nuclear or chemical?); negative results.

If positive, only with electrolytic cells?

What about heat measurements with gas cells?

- *Radiation*, if any: neutrons ($D + D \rightarrow {}^3\text{He} + n$); detection techniques, background events (external and/or internal); radioactivity (already present or induced); ${}^3\text{He}$ (mass spectrometry?)

Tritium ($D + D \rightarrow T + p$) detection techniques relative abundance: D/T ratios; related protons, if possible

Other fusion reactions



$D + D \rightarrow {}^4\text{He} + (20 \text{ MeV})$: exotic reaction detection and/or dissipation in lattice; ${}^4\text{He}$ mass spectrometry? Aneutronic fusion?

Relation between heat and radiation (if any): correlated, uncorrelated

The various possible combinations or the unexpected lack of correlations point out the difficulty of a possible occurrence of a nuclear-fusion process; on the other hand, a definite answer that could rule out real nuclear phenomena is not yet achieved. The reality of such phenomena, which seem to present different aspects in the case of electrolytic or gaseous cells, is strictly connected to the very critical experimental conditions (far from equilibrium) and the serious difficulty of controlling their evolution.

Still we are facing a field of research of fundamental interest not yet, as far as we actually know, open to important applications, which need further efforts from the experimental and theoretical point of view, to be brought back to the specialized laboratories and to the scientific audience.

4.3. The so-called 'Cold Fusion' Experiments (1989-2007)

FRANCESCO CELANI

INFN – National Laboratories - Frascati

The announcement by M. Fleischmann and S. Pons on March 23, 1989, that they had achieved "Cold Fusion" with a simple electrochemical experiment, spurred me to try and repeat the experiment with a mix of skepticism and hope.

In a special laboratory equipped in Room C of the INFN-LNGS (Gran Sasso Underground Laboratory, Italy) – which I knew very well due to a previous experiment I participated in as the main actor (acronym FLUNE, whose objective was measuring background neutrons within the underground Gran Sasso gallery, under construction at the time) – I made a long (1989-1991) campaign of measurements aimed at highlighting neutron emissions from the well-known D+D reaction. Such activity was made in collaboration with my LNF colleagues. They were so many at the beginning and then their number reduced when it was clear that the experiment was much more complex than it seemed initially. I shared this work also with my "usual" Selenia and CSM colleagues I had been collaborating with for some time for experiments on High Tc Superconductivity.

The materials studied and the procedures adopted for that kind of experiments were both "standard" (Palladium, Titanium, direct-current electrolysis of D₂O lithiated solutions) and non-conventional:

- a) low-power pulsed electrolysis of thin wall Pd tubes;
- b) YBCO charged with D₂ gas (and H₂ for comparison) at a high pressure (100 bar) and a low temperature 77 K: detection of possible neutron emission during the normal→superconducting→normal transition phases;
- c) stimulation of "extra-neutrons" at high multiplicity, still with deuterated YBCO, by using a very weak neutron source (²⁴¹Am-Be);
- d) D₂O-added zeolites;
- e) even a particular type of cement, super-quick-setting concrete, put in reaction with D₂O: the experiment was successfully reproduced also in Kamioka Laboratory-Japan by Prof. Steven Jones (BYU, Provo, USA).

The publications relating to this subject are numbered **1, 2, 3, 4, 5**.

After the first enthusiasms and the following burning disappointments, I realized that seemingly the sporadic anomalous phenomena did occur only under forced thermodynamic non-equilibrium state. Hence I came to the conclusion that the extreme irreproducibility of results could be ascribed to the imprecise knowledge and the criticality of the phenomenon's control parameters.

I was convinced that the reality of some experimental results, although irreproducible, could not be denied, therefore I decided it was worth "betting" my professionalism and my researcher credibility on this fascinating "New Frontier". I was well aware that the research work would turn out to be long and complex. As a matter of fact, before arriving at some concrete result it was necessary to "*discover and consolidate the culture*" underlying the phenomenon.

The acronyms of the performed experiments along with the relating INFN groups, as well as the co-financing bodies, and the main scientific collaborations are reported in the following list:

- a) *D₂O***: INFN Group 3, co-financed by CNR; in collaboration with SELENIA, CSM.
- b) *FERMI***: INFN Group 3;
- c) *FREE***: INFN Group 3; co-financed by: ORIM S.p.A. (Italy). In collaboration with Toyota company (Japan), MITI (Ministry Industry and Trade International, Japan); CSM-SKITEC
- d) *FREEDOM***: INFN Group 5; co-financed by: ORIM S.p.A.; in collaboration with CSM, EURESYS;
- e) *FREETHAI***: INFN Group 5; co-financed by: ORIM S.p.A., Pirelli Labs (Italy); in collaboration with CSM, EURESYS, STMicroelectronics, Osaka Univ. (Japan), Mitsubishi Heavy Industries (Japan);
- f) *DIAFF***: INFN Group 5; co-financed by: ORIM S.p.A., CSM; in collaboration with EURESYS, STMicroelectronics, Osaka Univ., Mitsubishi Heavy Industries.

From the "bureaucratic" point of view I have always been the national responsible for such experiments, with the exception of FERMI, which I was the Local Responsible for. FREETHAI and DIAFF have been multi-sectional experiments (Univ.-INFN Lecce e Univ.-INFN Perugia).

My activity in this regard has been very diversified and has followed the evolution of this line of research often harshly contrasted.

I here advance that the innovative contribution I made along with the multi-disciplinary group I am coordinating (5 to 20 researchers depending on the type of experiments) has been such that I won several kinds of acknowledgments/awards listed as follows:

- a) December 1994; appointed ex-officio Referee of ANS (American Nuclear Society);
- b) 1997: 2 International prizes on “Anomalies on Hydrogen/Deuterium-Loaded Metals”: a personal award of about € 3,000 by Fondazione CR Asti-FIAT Ricerche; a US\$ 10,000-scientific equipment by a US firm;
- c) National Prize (1st prize) at SIF Conference 2003 as the best Conference presentation, Section 6 (General Physics): a money prize of € 500 by SIF;
- d) Since October 2003: appointed member of the ISCMNS (International Society of Condensed Matter Nuclear Science) Executive Committee; in October 2006, his charge was renewed for the second three-year period (until October 2009);
- e) June 25, 2007: appointed member Honoris Causa of the Russian Physical Society;
- f) October 13, 2007; elected Vice President and Chairman of the ISCMNS Executive Committee by electronic ballot for a three-year period.

DC Electrolysis, International Trial

Following the afore-mentioned Underground experiments, in the **1992-1993** period I participated in an international trial (Japan, Italy, USA) aimed at verifying some macroscopic heat excess events obtained by Prof. Akito Takahashi (Osaka University). He used some particular Palladium plates produced by the Tanaka KK company, which for a long time (some weeks) underwent specific and complex electrolysis cycles (**Pub. 6, 7, 8**).

Although the results were poorer than Takahashi's – the kind of foil we used having a different batch from Takashi's – they were achieved by means of an experimental equipment particularly reliable and easy to calibrate, a flow calorimeter we designed and built in LNFs. Such results

definitely convinced me about the phenomenon existence – also as to thermal anomalies – although it was elusive and of low absolute value. In fact excess power, when obtained by chance, was of the order of 5-10% if compared with input power.

High-power Microsecond Pulsed Electrolysis

Following those results, in the **1993-1995** period, I treasured both the specific experience I built during the measurements made at LNGS (non-equilibrium phenomenon) and the flow calorimeter measurements at LNF using Takahashi's method (excess heat depends massively on the whole metallurgic characteristics and the chemical purity of Pd). Thus I changed the electrolysis state from DC – probably used by over 99% of electrochemists worldwide – to pulsed electrolysis, with pulses lasting microseconds, over-100A peak currents and up to-300V tensions.

Basically the idea was to attain non-equilibrium through pulses and depend less on the bulk composition of Pd thanks to the skin effect intrinsic to pulses.

At first, this procedure was long rejected by conventional electrochemists that deemed electrolysis *impossible* to perform by way of the procedure I adopted. I have been “obliged” to show my Colleagues – especially Japanese, U.S., and French – the exactness of my remarks. I purposely built special transparent pressurized electrolytic cells equipped with both electronic accessories and a small gas-collecting ball with the aim of measuring the deuterium leaking from the electrode at the end of the experiment even visually – the ball should have flown... The results have been published on a review and presented at a number of international conferences, giving rise to a widespread interest and endless questions (**Pub. 12, 15, 16**). However, such procedure definitely qualified me as a "highly innovative researcher", both in the limited and ultra-competitive world of Cold Fusion – some 300 researchers in 2004, recently increased to 1000 thanks to the interest raised by Pd nanoparticles as the cause generating anomalies (see below) – and the wider and self-controlled world of High-Tc Superconductivity (**Pub. 10, 11**).

It is noteworthy that, thanks to some highly innovative technologies developed for Cold Fusion – especially high-peak-power pulsed electrolysis – and applied also to my "conventional" studies on High-Tc Superconductivity, we succeeded in attaining a significant increase (over 10K) in the critical temperature of such materials (in particular, YBCO-

type superconductors, i.e., Yttrium, Barium, Copper, Oxide). To date, a so-treated compound is the most reported in field literature (**Pub. 9, 10, 11**) about maximum value of the superconducting critical temperature (T_c) value.

In the **1995-1997** period, I applied pulsed electrolysis not to foils but to long and thin Pd wires. Such further development is due, on the one hand, to many talks I had with Prof. Giuliano Preparata and Prof. Emilio del Giudice, who were the promoters of a new physical phenomenon they called "Cohn-Aharonov effect", capable of increasing the chemical overvoltage on the surface of any thin wire subjected to electric current. On the other hand, I was also driven by the need to use a simple and direct method for measuring hydrogen or deuterium concentration in Pd through the well-known Baranowsky curve which links the value of Pd resistivity to its hydrogen or deuterium content.

The results achieved have been particularly acknowledged (**Pub. 14, 17, 18, 19, 22**): they have been published on the *Physics Letters A* review (as many as 13 pages) and shown in several national and international conferences. They have also been widely presented by the diffusion press.

RF Electrolysis

An extreme application of the pulsing system has been RF electrolysis (approximately 90 MHz) with the concomitant "Preparata Effect" (the Cohn-Aharonov Effect was subsequently called so, after 2001, due to the premature death of Prof. Preparata) under AC voltage.

The results (**Pub. 20**) have been particularly interesting (apparent macroscopic resistance reduction of a Pd thin long wire down to zero Ohm values) and long-lasting (the experiment lasted over 4 months and was observed by many tens of researchers specifically coming from all over the world, even Fleischmann and Pons themselves). Yet they were found to be decidedly depending on:

- a) the shape of the RF wave (generated by the auto-oscillation of a specific MOS-Power type, pure non-sinusoidal, with a small but appreciable anodic spike, very-high-frequency (GHz) cathodic components generated by non-linear elements added to the circuit);
- b) the wire itself. Once broken it was impossible to reproduce the effect with other apparently-similar fragments, still donated by ORIM SpA (a company concerned with Pd recovery and purification from industrial waste).

"Zero" resistance measurements were performed with the RF impulser switched off. The phenomenon occurred only with Deuterium and not with Hydrogen. Furthermore, the maximum electrolyte temperature had to be lower than about 26 °C. The overall understanding of the above phenomenon is still an open issue.

The major experimental problem of the high-power impulsing system of long wires turned out to be the generation of spurious disturbs which very often irreparably damaged the remaining low-signal electronics used for the complete monitoring of the experiment. The current density passing through the Pd wire (with diameters of 50 μm and 100 μm) was of the order of 50000 A/cm² with peak values, in some specific experiments, up to 0.25 MA/cm². All of this occurred without taking into account the skin effect which becomes significant if we consider the brief duration of the pulses produced (500-5000 ns) and, above all, the rise time (from 100 ns up to about 500 ns, depending on the current supplied by the pulser I designed and built, as usual).

New types of salts in the electrolyte, other than LiOD

In 1998, even due to particularly limited funding, I tried to prevent the apparatus I owned from damaging and focused on developing some other electrolytic technique which might embed the advantages produced by long wires to those given by pulsing but without using the aforementioned high-power pulser.

Hence I resumed some studies I carried out *a latere* on non-conventional electrolytes starting from 1994, and I evidenced experimentally that the alkaline-earth elements could be used profitably to increase the overvoltage on the Pd surface, instead of Li generally used in this type of experiments. Furthermore, I was the *first one in the world* who introduced the use of *mercury salts* to counteract the inevitable damaging of the wire produced by the Hydrogen or Deuterium absorption (the so-called "embrittlement") and to further increase the overvoltage value thanks to the intrinsic electrochemical characteristics of the Hg metal (deposited on the cathode by the electrolysis).

A long systematic study involved the use of Sr salts in micromoles instead of Li – generally used in concentrations 10000-100000 times higher – together with Hg (in the form of HgCl₂) in relative concentrations about 5-10 times lower than Sr. The results with Hydrogen have been really interesting and above all reproducible, non only in our

laboratory. Upon my indication, the results have been *reproduced independently*, with their experimental apparatus, both at *Pirelli Labs* (Milan) and in the United States at SRII (*Stanford Research Institute International*) (**Pub. 26, 27**).

Detection of a new bacterium into D₂O

In the **1999-2000** period, the application of such technique to heavy water did not produce the expected results.

In particular, we observed that Hg seemed to "disappear" from the electrolytic solution and what is more the presence of a smell very similar to that of yoghurt was ever increasing (sic!).

In sum, I hypothesized that heavy water might contain some bacteria which could not proliferate under the usual electrolytic conditions of Cold Fusion (pH=13—14, due to LiOD 0.1-1M). Instead this was possible under our conditions with moderate salt concentration and pH=4, which favored the development of living forms (**Pub. 25**).

After a set of complex analyses, we actually evidenced the presence of at least 2 *new bacteria*. They have been identified by Dr. Giacomo D' Agostaro (microbiologist working at ENEA-Casaccia) as 2 *new species* and recorded into the specific biology data-bank (**Pub. 29, 30**): they have been assigned the names of *Ralstonia detusculanense* and *Stenotrophomonas detusculanense*. The prefix *de* comes from *deuterium* and *tusculanense* is in honour of the site it was found in, that is *Tusculum* (the original Latin name of Frascati).

The apparent disappearance of Hg from the electrolytic solution has been subsequently explained by the fact that one of the two new bacteria (*Ralstonia*) has the unusual ability to metabolize even the salts of some heavy metals (therefore Hg as well), that is to say it has chemiolitotrophic characteristics. Later, driven by the mere spirit of research (as the acronym INFN contains the final N standing for "...Nuclear") we tested its behaviour with *Uranium* too: it did "metabolize" it up to the considerable concentration of *10mM*.

The finding of the 2 new bacteria was reported on the review *Le Scienze* (Italian edition) published as scientific supplement to some large diffusion newspapers (*Il Sole 24 Ore, Il Giornale*).

At the LNF a study afternoon has been organized on June 11, 2001, in order to explain such a finding. The event witnessed a widespread

participation (room AE, 250 seats, overcrowded) from researchers in many diverse disciplines (Physicists, Chemists, Biologists, Physicians, Engineers, Geologists) and Institutions (INFN, ENEA, Universities, ISS, Armed Forces).

Very recently, in June 2007, the Collaboration group I do co-ordinate has been contacted by High Officers from the Center for Studies on Military Medicine (Roma) to evaluate the possibility of using *Ralstonia detusculanense* both to neutralize spent Trinitrotoluene (our bacterium, like some others, should be capable of metabolizing TNT as well) and to possibly recover some areas, theatre of wars, where the so-called "depleted Uranium" has been widely used. ENEA-Casaccia, "La Sapienza" University of Rome and a bio-reactor-producing company are involved in the Project, which is under the complete responsibility of the Italian Minister of Defence, and is still under evaluation for all of those complex "health-logistic-economic-political-strategic" aspects.

It is recent news (2005) that – apart from us – the Spanish Company for Nuclear Energy (ENDESA) has found a bacterium of the *Ralstonia detusculanense* type even in the cooling pools of spent fuel bars and, similarly to our preliminary work, they have used such bacterium to attain the bio-concentration of particular metals, specifically radioactive isotopes. They have successfully applied such technique for ^{60}Co bio-concentration and patented the process at the international level. Their scientific work has been published in *International Microbiology* 8, pp. 223-230 (2005).

From recent private news (2007), we came to know that further studies are in progress to apply such bacteria to ^{90}Sr , ^{135}Cs , ^{137}Cs as well, i.e., to three of the most dangerous fission products from nuclear reactors.

The only comfort of this event is that the Spanish group had the "good taste" of not changing the name of the bacterium they rediscovered.

As a mere curiosity (the news appeared on Science and was reported in "Le Scienze" in September 2006) of some practical and financial interest, I do inform you that recently the origin of golden nuggets has been shown: it is due to the very action of the *Ralstonia metallidurans* bacterium.

The *metallidurans* type is, in many aspects, a variant "less resilient" unfavourable environmental conditions if compared with *detusculanense*. A systematic work on the various *Ralstonia* species has been performed by the U.S. DoE (U.S. Department of Energy) with the complete sequencing of some of them.

NOTE

Hence I think it is worth wishing for INFN to make the proper scientific policy choices in order to foster the application of this new type of bacterium for the environmental bio-remediation from heavy and/or radioactive metal contamination.

Use of hydro-alcoholic solutions

Starting from 2001, in order to appreciably reduce the problems arising from the presence of bacteria in heavy water, we studied new types of electrolytic solutions. A long series of electrochemical considerations led us to use hydro-alcoholic solutions (ethyl alcohol), first added with Hydrogen and then deuterated. The results were interesting even because it was again possible to perform measurements (**Pub. 31, 32**) of Tritium excess statistically significant. The whole thanks both to the very reduced concentration of this isotope in the initial alcoholic solution and to the low D₂O percentage (5-7%) added (the T concentration in D₂O that we used is quite low in any case, equivalent to a specific activity of about 200 dpm/ml).

Evidence of isotopic/composition variations, use of Th

Later on, starting from July 2002, incentivated by the experimental results attained by a Japanese research group working at Mitsubishi Heavy Industries (MHI) and coordinated by Dr. Yasuhiro Iwamura, we began performing systematic measurements on the possible anomalous presence of elements in the electrolytic cell following the cathodic hypercharging process. To such purpose we set up a new type of electrolytic cell, made of glass and PTFE, optimized from a "cleaning" point of view. The measurements were performed by using the well-known and extremely sensitive ICP-MS analytical techniques.

The results were successful since we evidenced composition and isotopic anomalies similar to those detected by the Mitsubishi group working with a gas system (**Pub. 34**).

Anomalies became much more significant (**Pub. 35, 36, 41**) when the Strontium-Mercury previously used was replaced with Thorium-Mercury. The use of Thorium was also motivated by our will to understand with a higher level of confidence some explorative measurements we performed in 1998 (**Pub. 23**) just using Thorium. Furthermore, Th has the unusual property to make thin wires "more resistant" against mechanical and thermal stress.

As a matter of fact, after adding Th micromoles (in the form of soluble salts) to our electrolytic solutions, the big problem of the sudden and uncontrollable rupture of the thin (50µm diameter) Pd wires occurred in our previous experiments has actually been strongly reduced.

The experimental evidence of the inexplicable "transmutation" of ^{88}Sr (into ^{96}Mo), ^{133}Cs (into ^{141}Pr) particularly by applying the method developed by Yashuiro Iwamura (MHI), and strengthened by qualitatively-similar evidence in my electrolytic cells (**Pub. 34, 35, 36, 41**), led me to put forward – at the Ministerial level – a particular international research project since 2005. It had 3 time-scaled objectives, whose final aim is to replace natural with radioactive Sr and Cs, trying to "transmute" them into less dangerous elements than the original ones. Obviously, the radioactive Sr and Cs are those contained in the fission products from any type of reactor and represent – after 10-year cooling down in the appropriate pools – the great majority of the above products. A special report has been presented in the ICCF12 (**Pub. 42**) in 2005.

At present, after alternating and complex events, the project – representing a great economical effort of about €30M – was sent to MSE (the Italian Ministry for Economic Development) last July 2007 and the reply by the International Referees is expected by January 2008. The whole of the projects which ours is also part of has been given the following title by MSE: ¹Bando Energia Programma 2015, Area Tecnologica OTP1 (Tecnologie per la gestione dell’impatto ambientale sulla generazione d’energia).

The project has been given the name **CETRA**. Specifically, it deals with: “Technology for the reclamation of radionuclides produced by electric power generation facilities. Industrial exploitation – through micro-and nano-technologies – of element transmutation phenomena so far evidenced in laboratory.

The Companies/Institutions involved in our project are the following:

STMicroelectronics (Cornaredo and Catania sites; Industrial Company of the "big enterprise" type, heading the project according to MSE ministerial directives for this kind of projects); INFN-LNF; ORIM; CSM; Politecnico di Milano (CESNEF group); ASM (research division of the electric energy company in Brescia). I am the “*Scientific Responsible*” for the project.

¹ *Translator's note:* Call for proposals – Energy Programme 2005, Technology Area OTP1 (Technologies for Managing the Environmental Impact on Energy Generation)

Non-ambiguous Identification of the site originating heat excess

Another important aspect shown in the studies to evidence possible heat excess events in systems with Pd and D₂O wire cathode is the usefulness of correlating often-low heat excess with another process parameter. This allows to obtain data with a much higher "confidence" level than one parameter, i.e., the solution temperature. In the case of thin wires, the most comfortable parameter to measure the D/Pd value is based on the so-called "Baranowsky curve" linking Deuterium concentration to the resistivity level of the new PdD_x compound. Unfortunately, the curve trend has a maximum value (corresponding to about 0.8 for D/Pd and 2 for R/R₀, with R₀ = 1 in the absence of Deuterium) at a concentration generally considered insufficient to obtain thermal anomalies: subsequently it decreases both for D/Pd < 0.8 and for D/Pd > 0.8 values.

The problem arises when, due to electrolysis, although documenting (as a function of time) the possible resistance increase, its passing through a maximum and its decrease to an "interesting" value (e.g., R/R₀=1.6 corresponding to a D/Pd value of 0.95), owing to sudden degassing at relatively-low D/Pd values (with intrinsic duration of a few tens of ms, given the limited 50 μm width of the wire used to be compared with the 10-second acquisition cycle), the undesired event causing heavy effects from the experimental point of view would be completely ignored.

The only resource for the ambiguity to be resolved is the use of the resistance thermal coefficient (RTC) of the PdD_x compound. Such RTC has quite low value (a minimum) at D/Pd of about 0.8 and grows rapidly (see **Pub. 27, 44**), for small concentration variations, to high values. In sum, I developed an electronic circuit which cyclically, i.e., every 100 seconds, injects AC currents (at 10 kHz) with low (the reference) and high intensity thus allowing to resolve the ambiguity on the real D/Pd value through the effect the constant Joule heating on the wire has on the R/R₀ value. Such circuit (**Pub. 38**) has been very appreciated by the numerous colleagues using thin wires and – properly adapted to the different experimental set-ups – has become the current "standard" to qualify possible heat excess events. Besides the Invited Paper, I also gave a kind of over-3-hour "tutorial lesson" at the ICCF11 Conference in Marseilles to explain the hardware details of the procedure. Due to time reasons, the lesson was given to a specialist audience after the scheduled presentations.

Electrochemical D₂ Compression in a Hollow Pd Cathode

In 2005, against my will I was involved in a scientific controversy dealing with the theoretical impossibility to "compress" Hydrogen or Deuterium, in a hollow Pd cathode, with a practically open electrolytic cell (overpressure of about 0.1 bar) at pressures of a few bar higher. Until 2005 most of the experimental CMNS research used electrolysis as the key method to compress Deuterium into Pd at equivalent average pressures of even over 50000 bar (with D/Pd = 0.95), and at (estimated) surface values of some Mbar. Therefore, denying the possibility of electrochemical compression was the same as denying the existence of ALL the experimental CMNS studies based on electrolysis.

Since 1992 I had several experimental results evidencing the goodness of the electrolytic method and the controversy raised by a well-known, powerful, and influential nuclear chemist – Prof. Camillo Franchini from CISAM (S. Piero a Grado) – had become increasingly widespread (even a “BLOG” accessed by tens of thousands visitors). Hence– being an eminent figure of CMNS in Italy – I was obliged to reproduce in miniature the original experimental apparatus related to electrochemical compression. Such apparatus was developed in 1955 by Prof. Yoshiaki Arata (Osaka University, Japan) within “Cold Fusion” research for the production of pressurized D₂ (up to about 1000 bar).

Well then, the controversy did not end, notwithstanding my successful experimental evidence of the electrolytic method goodness: pressures of about 9 bar were achieved with a hollow Pd₇₅Ag₂₅ alloy cathode, with a 50 μm-thick wall (**Pub. 46**), and about 49 bar with a hollow hyperpure Pd cathode having a 250μm-thick wall (therefore with a pressure limit depending only on the mechanical resistance of the Pd tube). According to Franchini, this was ascribable to the fact that if an experiment is not supported by an exhaustive theoretical explanation, it surely has some hidden "bug" even if experimentally it *seems* to be working. As a supporter of the “Galilean” experimental method, of course I do not agree with the pseudo-theoretical/philosophical reasons advanced. On the other hand, the gauge needle put at the cathode outlet is not aware of “theories” and moves according to the specific kind of electrolysis performed!

The Revolution of Deuterated Nanoparticles

During the ICCF12 Conference in 2005, in the framework of CMNS studies, the afore-mentioned Prof. Arata announced an innovative experimental set-up which in many aspects was a real “revolution” (see the same references given in **Pub. 44**, except the pages 373-403, which are replaced by pp. 44-54).

In brief, by using the whole of the various innovative methodologies pioneered by Arata himself in his very long career, he succeeded in evidencing, in an elegant non-ambiguous manner, the generation of anomalous heat at high temperatures ($>140\text{ }^{\circ}\text{C}$), when proper Pd nanoparticles, homogeneously dispersed into a Zirconia matrix and inserted into a hollow Pd cathode, were put in contact with pressurized Deuterium gas ($>60\text{ bar}$).

In detail, electrolysis was no longer used for “hyper-loading” of Deuterium into Pd but the equivalent effect was referred to the particular *intrinsic properties* of some specific *nanometric* materials. The immediate advantage was energy saving due to the absence of electrolytic processes: nanoparticles absorbed Deuterium by pressure one time only, at the beginning of the experiment. An additional advantage was the opportunity to introduce into the reactor just the “active material” which, amongst other things, as to Hydrogen or Deuterium absorption, had a chemical and physical behavior completely unexpected and absolutely superior to any bulk material.

The material developed by Arata – amorphous $\text{Pd}_{35}\text{Zr}_{65}$ alloy, target composition of $\text{Pd}_{35}\text{-(ZrO}_2\text{)}_{65}$ – by metallurgical procedure presented limits such as production costs extremely high and complex (melt-spinning metallurgy at about $1200\text{ }^{\circ}\text{C}$ in a protective atmosphere, cooling speed of the order of one million $^{\circ}\text{C}$ per second, selective oxidation of Zr), and maximum operating temperature of the $\text{D}_x\text{-[Pd}_{35}\text{-Zr}_{65}\text{]}_y$ compound of the order of $210\text{ }^{\circ}\text{C}$.

The aims of our research were the following:

- a) simplifying the production process of the nanostructured material by using chemical manufacturing methodologies instead of metallurgic ones;
- b) achieving, at an equal pressure (of the order of 60 bar at room temperature), a maximum operating temperature substantially higher (of the order of $300\text{ }^{\circ}\text{C}$), i.e. capable of achieving a better thermal

performance in the case of a “technological” application of the phenomenon;

- c) achieving a simplified reaction chamber system (only one SS chamber, i.e., without any hollow Pd cathode);
- d) simplifying the system for measuring thermal anomalies from the operational point of view: two chambers as equal as possible have been built, one filled with inert material and the other with potentially “active” material. Thus, a differential measurement system has been implemented.

The setting-up of the new measurement system and the development of new materials began on July 2006.

Many materials/compositions have been studied and are all listed in **Pub. 47**. For the time being this publication is only available as a preprint by LNF in anticipation of being published in a World Scientific volume. Meanwhile, you can find it entirely **enclosed** as a **pdf** file((LNF-07-(18P)).

Compared to Pub. 47 (of July 2007), the present situation has further improved. Thanks to the substantial enhancement – during the calcination→sinterization phase – I made to the manufacturing process (that we ourselves developed), we achieved a heat excess of the order of 500 mW/g of Pd, at a temperature of 300 °C. For comparison, the best results with Pd_black of High Surface Area supplied by Aldrich Chemical Company had been of about 130 mW/g which degraded to only 40 mW/g in a few days due to thermal cycles (300→20→300 °C).

A paper has been presented in the recent 8th International Workshop on Deuterium-Metal Anomalies, held last October 2007 in Catania, and is still being worked out. The material we entirely developed in LFN is based on the incipient wetting impregnation of nanoporous material (gamma-Alumina, average pore diameter of 5.8 nm). Such material is “filled” with a mixture of palladium and strontium soluble salts (nitrates) opportunely decomposed at high temperatures in a controlled-atmosphere oven.

From a decidedly scientific point of view, since 2004 (**Pub. 41**), observing the surface of some Pd wires producing heat excess by SEM (Scanning Electron Microscope), we realized how important are nanometric and/or fractal structures as regards the production of thermal and/or isotopic-compositional anomalies. In this respect, I also developed an opportune electronic circuitry aimed at maximizing the production of such nanostructures (**Pub. 43**).

In conclusion, the slow process of “culture” acquisition to make an elusive phenomenon like “cold fusion” reproducible seems to be on its way to a happy “scientific” conclusion, also thanks to my contribution. Further studies to be carried out allowing to pass to a “technological” phase only depend, in my opinion, on the economic effort to be made. Obviously, given the complexity of the problem, I think that a multi-discipline approach is indispensable.

To achieve this goal we have recently put forward a small international four-year project (Italy-China, MIUR-MOST collaboration), for a total amount of about €2M, in order to further develop our nanoparticles manufacturing procedure and to increase the operating temperature (and experimental set-up) up to 600 °C. As for the Chinese colleagues, their aim is to use carbon SWNT (Single Wall Nano Tube), opportunely modified, with pressurized deuterium. At present some Chinese research groups have developed a new technique to produce the very expensive SWNTs at prices as much as about 100 times lower than those applied in the rest of the world.

It is a FIRB project registered with under project number RBIN07RSBE. As to its organizational aspect, for the Italian party, the operational coordinating unit is the University of Lecce. As to economic efforts and human resources they are supplied by: INFN-LNF, STMicroelectronics, CSM.

List of Publications

- 1) F. CELANI, A. SPALLONE, M. DE FELICI, F. L. FABBRI, L. LIBERATORI, A. SAGGESE, V. DI STEFANO, P. MARINI, S. PACE, S. BIANCO, L. DONATI: *"Results of the 1st generation experiments, at Gran Sasso underground laboratory, on nuclear cold fusion."* Conf. Proc. "Understanding Cold Fusion Phenomena"; Edited by R.A.Ricci, E.Sindoni and F.De Marco - SIF, ISBN 88-7794-031-X, Vol. 24, pg. 257-266 (1989). Invited Paper.
- 2) F. CELANI, A. SPALLONE, L. LIBERATORI, B. STELLA, F. FERRAROTTO, M. CORRADI, P. MARINI, S. FORTUNATI, M. TULUI. *"Measurements in the Gran Sasso Laboratory: evidence for nuclear effects in electrolysis with Pd/Ti and in different tests with Deuterated High Temperature Superconductors."* AIP Conference Proceedings Vol. 228: "Anomalous Nuclear Effects in Deuterium/Solid Systems" Provo, Utah (USA), pg. 62-100, (1990). ISBN: 0-88318-833-3. Invited Paper.
- 3) F. CELANI, A. SPALLONE, S. PACE, L. LIBERATORI, A. SAGGESE, V. DI STEFANO, P. Marini. *"Further measurements on electrolytic cold fusion with D₂O and Pd at Gran Sasso laboratory "* Fusion Technology, Vol. 17- 4, pg.718-724, (1990). ISSN: 0748-1896.
- 4) F. CELANI, A. SPALLONE, L. LIBERATORI, F. CROCE, L. STORELLI, S. FORTUNATI, M. TULUI, N. SPARVIERI. *"Search for neutron emission from Deuterided High Temperature Superconductors in a very low background environment."* SIF Conf. Proc. Vol. 33 "The Science of Cold Fusion" Ed. T. BRESSANI, E. DEL GIUDICE, G. PREPARATA. II Annual Conference of Cold Fusion. Como, Italy pg. 113-121; (1991). ISBN: 88-7794-045-X. Invited Paper.
- 5) F. CELANI, A. SPALLONE ET AL. "Search for enhancement of neutron emission from neutron-irradiated, deuterited, high temperature superconductors in a very low background environment." Fusion Technology, Vol. 22, pg. 181, (1992).
- 6) F. CELANI, A. SPALLONE, P. TRIPODI, A. NUVOLI. *"Measurements of excess heat and Tritium during self-biased pulsed electrolysis of Pd-D₂O."* Proceedings of the Third Intern. Conf. on Cold Fusion.- Nagoya, Japan. "Frontiers of Cold Fusion". Edited by H. Ikegami, Universal Academy Press, Inc. Tokyo, Japan. Frontiers Science Series No. 4, pg. 93-105. (1992). ISBN: 4-946443-12-6. Invited Paper.
- 7) B. STELLA, M. CORRADI, F. FERRAROTTO, V. MILONE, F. CELANI, A. SPALLONE. *"Evidence for stimulated emission of neutrons in Deuterated Palladium."* Proceedings of the Third Intern. Conf. on Cold Fusion.- Nagoya, Japan. "Frontiers of Cold Fusion". Edited by H.Ikegami, Universal Academy Press, Inc. Tokyo, Japan. Frontiers Science Series No. 4, pg. 437-440. (1992). ISBN: 4-946443-12-6.

- 8) B. STELLA, M. ALESSIO, M. CORRADI, F. CROCE, F. FERRAROTTO, S. IMPROTA, N. IUCCI, V. MILONE, VILLORESI, F. CELANI, A. SPALLONE: *"The FERMI apparatus and a measurement of Tritium production in an electrolytic experiment."* Proceedings of the Third Intern. Conf. on Cold Fusion.- Nagoya, Japan. "Frontiers of Cold Fusion". Edited by H.Ikegami, Universal Academy Press, Inc. Tokyo, Japan. Frontiers Science Series No. 4, pg. 503-506. (1992). ISBN: 4-946443-12-6.
- 9) F. CELANI, M. BOUTET, D. DI GIOACCHINO S. PACE, M. POLICHETTI: *"Enhancement of critical temperature up to 100 K of YBCO ozone annealed pellets by deuterium absorption"*, Physics Letters A, Vol. 183, pg. 238-242, (1993).
- 10) F. CELANI, M. BOUTET, D. DI GIOACCHINO, A. SPALLONE, P. TRIPODI, S. PACE, M. POLICHETTI, A. MARINI: *"First results about hydrogen loading by means of pulsed electrolysis of Y1Ba2Cu3O7 pellets"* Physics Letters A, Vol. 189, pg. 395, (1994).
- 11) D. DI GIOACCHINO, M. BOUTET, A. SPALLONE, P. TRIPODI, F. CELANI: *"AC susceptibility Measurements of YBCO sintered pellets loaded with Hydrogen by microsecond pulsed electrolysis."* Current Topics in Magnetic Research, Pg. 1, (1994).
- 12) F. CELANI, A. SPALLONE, P. TRIPODI, A. NUVOLE, A. PETROCCHI, D. DI GIOACCHINO, M. BOUTET, P. MARINI, V. DI STEFANO: *"High power microsecond pulsed electrolysis for large deuterium loading on Pd plates."* Fusion Technology, Vol. 26-4T, pg. 127-137, (1994). ISSN: 0748-1896.
- 13) B. STELLA, F. CELANI, M. CORRADI, F. FERRAROTTO, N. IUCCI, V. MILONE, A. SPALLONE, G. VILLORESI: *"A high efficiency, low background neutron and gamma detector for cold fusion experiments."* Nuclear Instruments & Methods in Physics Research A, Vol. 355, pg. 609-617, (1995).
- 14) F. CELANI, A. SPALLONE, P. TRIPODI, A. PETROCCHI, D. DI GIOACHINO, P. MARINI, V. DI STEFANO, S. PACE, A. MANCINI: *"High power microsecond pulsed electrolysis using Palladium wires: evidence for a possible phase transition under Deuterium overloaded conditions and related excess heat"* Proceedings of the "Fifth Intern. Conf. on Cold Fusion ", April 9-13 1995 - Monte-Carlo, Monaco. ICCF5 Copyright 1995. pg.57-68, (1995). **Invited Paper.**
- 15) F. CELANI, A. SPALLONE, P. TRIPODI, A. PETROCCHI, D. DI GIOACCHINO, P. MARINI, V. DI STEFANO, M. DIOCIAIUTI, A. MANCINI: *"Study of Deuterium charging behaviour in Palladium and Palladium alloy plates, changing surface treatments, by microsecond pulsed electrolysis."* Proceedings of the "Fifth Intern. Conf. on Cold Fusion ", April 9-13 1995 - Monte-Carlo, Monaco. ICCF5 Copyright 1995. pg.411-418, (1995).

- 16) F.CELANI, A. PETROCCHI, A. SPALLONE, P. TRIPODI, D. DI GIOACCHINO, M. NAKAMURA, P. MARINI, V. DI STEFANO, G. PREPARATA, M. VERPELLI. *"Numerical simulation of Deuterium loading profile in Palladium and Palladium alloy plates, from experimental data obtained using μ s pulsed electrolysis"* Proceedings of the "Fifth Intern. Conf. on Cold Fusion ", April 9-13 1995 - Monte-Carlo, Monaco. ICCF5 Copyright 1995. pg. 407-410, (1995).
- 17) F. CELANI, A. SPALLONE, P. TRIPODI, A. PETROCCHI, D. DI GIOACHINO, P. MARINO, V. DI STEFANO, A. MANCINI "Deuterium overloading of palladium wires by means of high power microsecond pulsed electrolysis: suggestions of a phase transition and related excess heat" Physics Letters A, Vol. 214, pg. 1-13, (1996).
- 18) F. CELANI, A. SPALLONE, P. TRIPODI ET AL. "Reproducible D/Pd ratio over 1 and excess heat correlation by 1 microsecond pulse high current electrolysis." Fusion Technology, Vol.29, pg. 398-404, (1996).
- 19) F. CELANI, A. SPALLONE, P. TRIPODI, D. DI GIOACCHINO, P. MARINI, V. DI STEFANO, A. MANCINI, S. PACE: "New kinds of electrolytic regimes and geometrical configurations to obtain anomalous results in Pd(M) systems." Proceedings of the Sixth Intern. Conf. on Cold Fusion: "Progress in New Hydrogen Energy" 1996 - Sapporo, Japan. Edited by Makoto Okamoto, Pub. by: NEDO, IAE, MITI (Japan). Vol. 1, pg. 93-104, (1996) Invited Paper.
- 20) F. CELANI, A. SPALLONE, P. TRIPODI, D. DI GIOACCHINO, A. MARINI, A. MANCINI: *"Observation of strong resistivity reduction in a Palladium thin long wire using ultra-high frequency pulsed electrolysis at D/Pd >1"* Proceedings of the Sixth Intern. Conf. on Cold Fusion: "Progress in New Hydrogen Energy" 1996 - Sapporo, Japan. Edited by Makoto Okamoto, Pub. by: NEDO, IAE, MITI (Japan). Vol. 1, pg. 228-233, (1996),
- 21) D. DI GIOACCHINO, P. TRIPODI, F. CELANI, A. SPALLONE: "Further enhancement of the critical temperature up to 105 K of hydrogen loaded YBCO melted samples by microsecond pulsed electrolysis." Physics Letters A Vol. 225 pg. 326-330 (1997).
- 22) F. CELANI, A. SPALLONE, P. TRIPODI, D. DI GIOACCHINO, S. PACE, G. SELVAGGI, P. MARINI, V. DI STEFANO, M. NAKAMURA, A. MANCINI: *"The effect of gamma-beta phase on H(D)/Pd overloading."* Proceedings of the "Seventh Intern. Conf. on Cold Fusion", Vancouver, Canada, Apr. 1998 Vol. 1, pg. 62-67 (1998). Invited Paper.
- 23) F. CELANI, M. ACHILLI, A. BATTAGLIA, C. CATTANEO, C. BUZZANCA, P.G. SONA, A. MANCINI: *"Preliminary results with "Cincinnati Group Cell" on Thorium "transmutation" under 50Hz, AC excitation"* Proceedings of the "Seventh Intern. Conf. on Cold Fusion", Vancouver, Canada, Apr., 1998 Vol. 1, pg. 56-61 (1998). **Invited Paper.**

- 24) P. TRIPODI, D. DI GIOACCHINO, F. CELANI, J. D. VINKO: “Increasing of superconducting pinning potential U_p and critical current J_c due to hydrogen loading in sintered YBCO” Physical C, Vol. 341-348, pg. 1127 (2000).
- 25) F. CELANI, A. SPALLONE, P. MARINI, V. DI STEFANO, M. NAKAMURA, A. MANCINI, S. PACE, P. TRIPODI, D. DI GIOACCHINO, C. CATENA, G. D’AGOSTARO, R. PETRAROLI, P. QUERCIA, E. RIGHI, G. TRENTA: “High Hydrogen loading into thin Palladium wires through precipitate of alkaline-earth carbonate on the surface of cathode: evidence of new phases in the Pd-H system and unexpected problems due to bacteria contamination in the heavy water” Proceedings of the “8th International Conference on Cold Fusion”, Lerici (La Spezia) May 2000 SIF - Conf. Proc. Vol. 70, pg 181-190, (2000). Edited by F. Scaramuzzi, Compositori–Bologna. ISBN: 88-7794-256-8 Invited Paper.
- 26) A. SPALLONE, F. CELANI, P. MARINI AND V. DI STEFANO: “New electrolytic procedure for the obtainment of very high H/Pd loading ratios: preliminary attempts for its application to the D-Pd system.” Proceedings of the “8th International Conference on Cold Fusion”, May 2000, Lerici (Italy) SIF - Conf. Proc. Vol. 70, pg 191-198, (2000). Edited by F. Scaramuzzi, Compositori–Bologna. ISBN: 88-7794-256-8.
- 27) P. TRIPODI, M.C.H. MCKUBRE, F.L. TANZELLA, P.H. HONNOR, D. DI GIOACCHINO, F. CELANI, V. VIOLANTE: “Temperature coefficient of resistivity at compositions approaching PdH” Physics Letters A Vol. 276, pg. 122-126, (2000).
- 28) F. CELANI, D. DI GIOACCHINO, P. TRIPODI: “Room temperature oxidation of sintered YBCO using microsecond pulsed electrolysis” Physica C, Vol. 341-348, pg. 1135 (2000).
- 29) G. D’AGOSTARO, F. CELANI ET AL. (FREEDOM Collaboration): “*Ralstonia detusculanense*” National Centre Biology Information-GenBank (Bethesda, USA) Locus: AF280433; Taxonomy ID:148618; October 24, 2000 <http://www.ncbi.nlm.nih.gov/>
- 30) G. D’AGOSTARO, F. CELANI ET AL. (FREEDOM Collaboration): “*Stenotrophomonas detusculanense*” National Centre Biology Information-GenBank (Bethesda, USA) Locus: AF280434; Taxonomy ID:148630; October 24, 2000 <http://www.ncbi.nlm.nih.gov/>
- 31) F. CELANI, A. SPALLONE, P. MARINI, V. DI STEFANO, M. NAKAMURA, A. MANCINI, G. D’AGOSTARO, E. RIGHI, G. TRENTA, P. QUERCIA, C. CATENA: “Electrochemical D loading of Palladium wires by heavy ethyl-alcohol and water electrolyte, related to *Ralstonia* bacteria problematics” Proceedings of the 9th International Conference on Cold Fusion: “Condensed Matter Nuclear Science” Beijing (China), May 19-24, 2002; pg. 29-35 (2002). Edited by Xing Z. Li. ISBN: 7-302-06489-X. **Invited Paper.**

- 32) F. CELANI, A. SPALLONE, P. MARINI, V. DI STEFANO, M. NAKAMURA, E. RIGHI, G. TRENTA, P. QUERCIA, A. MANCINI, G. D'AGOSTARO, C. CATENA, S. SANDRI, C. NOBILI, V. ANDREASSI: "*Evidence of anomalous Tritium excess in D/Pd overloading experiments*" Proceedings of the 9th International Conference on Cold Fusion: "Condensed Matter Nuclear Science" Beijing (China), May 19-24, 2002; pg. 36-41, (2002). Edited by Xing Z. Li. ISBN: 7-302-06489-X. Invited Paper.
- 33) A. SPALLONE, F. CELANI, P. MARINI AND V. DI STEFANO: "*Experimental studies to achieve H/Pd loading ratio close to 1 in thin wires, using different electrolytic solutions*" Proceedings of the 9th International Conference on Cold Fusion: "Condensed Matter Nuclear Science" Beijing (China), May 19-24, 2002; pg. 19-24, (2002). Edited by Xing Z. Li. ISBN: 7-302-06489-X
- 34) F. CELANI, A. SPALLONE, P. MARINI, V. DI STEFANO, M. NAKAMURA, A. MANCINI, G. D'AGOSTARO, E. RIGHI, G. TRENTA, P. QUERCIA, C. CATENA, V. ANDREASSI, F. FONTANA, D. GARBELLI, L. GAMBERALE, D. AZZARONE, E. CELIA, F. FALCIONI, M. MARCHESINI, E. NOVARO: "*Unexpected detection of new elements in electrolytic experiments with Deuterated ethyl alcohol, Pd wire, Sr and Hg salts*" Proc. of 4th Meeting of Japan CF Research Society; October 2002, Iwate, Japan. Vol.4, pg. 17-21, (2002). <http://dragon.elc.iwate-u.ac.jp/jcf/file/jcf4-05.pdf>. **Invited Paper**
- 35) F. CELANI, A. SPALLONE, E. RIGHI, G. TRENTA, C. CATENA, G. D'AGOSTARO, P. QUERCIA, V. ANDREASSI, P. MARINI, V. DI STEFANO, M. NAKAMURA, A. MANCINI, P.G. SONA, F. FONTANA, L. GAMBERALE, D. GARBELLI, F. FALCIONI, M. MARCHESINI, E. NOVARO, U. MASTROMATTEO: "*Thermal and isotopic anomalies when Pd cathodes are electrolysed in electrolytes containing Th-Hg salts dissolved at micromolar concentration in C₂H₅OD/D₂O mixtures*" Proc. of 10th International Conference on Cold Fusion. 24-29 August 2003, Cambridge (MIT), Massachusetts, USA. Condensed Matter Nuclear Science series World Scientific, pg. 379-397, (2004). ISBN 981-256-564-7 **Invited Paper**
- 36) F. CELANI, A. SPALLONE, P. MARINI, V. DI STEFANO, M. NAKAMURA, A. MANCINI, P.G. SONA, E. RIGHI, G. TRENTA, C. CATENA, G. D'AGOSTARO, P. QUERCIA, V. ANDREASSI, F. FONTANA, L. GAMBERALE, D. GARBELLI, E. CELIA, F. FALCIONI, M. MARCHESINI, E. NOVARO, U. MASTROMATTEO: "*Further tests on composition and isotopic anomalies when Pd thin cathodes are electrolyzed in acidic C₂H₅OD/D₂O mixtures added with Th-Hg salts at micromolar concentration*" Proc. of 5th Meeting of Japan CF Research Society; December 2003, Kobe, Japan. Vol.5, pg. 41-45, (2003). http://dragon.elc.iwate-u.ac.jp/jcf/file/jcf5/jcf5_09.pdf **Invited Paper**

- 37) A. LORUSSO, V. NASSISI, E. FILIPPO, M. DI GIULIO, D. MANNO, G. BUCCOLIERI, F. CELANI: “*Measurements of new elements in Pd-H₂ thin films*” Proc. of 5th Meeting of Japan CF Research Society; december 2003, Kobe, Japan. Vol.5, pg. 19-22, (2003). http://dragon.elc.iwate-u.ac.jp/jcf/file/jcf5/jcf5_05.pdf
- 38) F. CELANI, A. SPALLONE, E. RIGHI, G. TRENTA, C. CATENA, G. D’AGOSTARO, P. QUERCIA, V. ANDREASSI, P. MARINI, V. DI STEFANO, M. NAKAMURA, A. MANCINI, P.G. SONA, F. FONTANA, L. GAMBERALE, D. GARBELLI, E. CELIA, F. FALCIONI, M. MARCHESINI, E. NOVARO, U. MASTROMATTEO: “*Innovative procedure for the, in situ, measurement of the resistive thermal coefficient of H(D)/Pd during electrolysis; cross-comparison of new elements detected in the Th-Hg-Pd(H) electrolytic cells*” Proc. of 11th International Conference on Cold Fusion. 31 October-5 November 2004, Marseilles, France. Condensed Matter Nuclear Science series. World Scientific, pg. 108-127, (2005). ISBN 981-256-640-6 **Invited Paper**
- 39) T. MIZUNO, T. AKIMOTO, A. TAKAHASHI, F. CELANI. “*Neutron emission from D₂ gas in magnetic fields under low temperature*” Proc. of 11th International Conference on Cold Fusion. 31 October-5 November 2004, Marseilles, France. Condensed Matter Nuclear Science series. World Scientific, pg. 312-323, (2005). ISBN 981-256-640-6
- 40) A. SPALLONE, F. CELANI, P. MARINI, V. DI STEFANO. “*An overview of experimental studies on H/Pd over-loading with thin Pd wires and different electrolytic solutions*”. Proc. of 11th International Conference on Cold Fusion. 31 October-5 November 2004, Marseilles, France. Condensed Matter Nuclear Science series. World Scientific, pg. 392-404, (2005). ISBN 981-256-640-6
- 41) F. CELANI, A. SPALLONE, P. MARINI, V. DI STEFANO, M. NAKAMURA, F. TODARELLO, A. MANCINI, P.G. SONA, E. RIGHI, G. TRENTA, C. CATENA, G. D’AGOSTARO, P. QUERCIA, V. ANDREASSI, F. FONTANA, L. GAMBERALE, D. GARBELLI, E. CELIA, F. FALCIONI, M. MARCHESINI, E. NOVARO, U. MASTROMATTEO. “*Further Studies, about new elements production, by electrolysis of cathodic Pd thin wires, in alcohol-water solutions (H, D) and Th-Hg salts-New procedures to produce Pd nano-structures*” Proc. of 6th Meeting of Japan CF Research Society; April 27-28, 2005 Tokyo Institute of Technology, Japan. Vol.6, pg. 1-10, (2005) http://dragon.elc.iwate-u.ac.jp/jcf/file/jcf6/jcf6_proceedings.pdf **Invited Paper**
- 42) A. TAKAHASHI, F. CELANI, Y. IWAMURA. “*The Italy-Japan project - Fundamental research on cold transmutation process for treatment of nuclear wastes*” Proc. of 12th International Conference on Cold Fusion. 27 November-2 December 2005, Yokohama, Japan. Condensed Matter Nuclear Science series. World Scientific, pg. 289-292, (2006). ISBN 981-256-901-4

- 43) F. CELANI, A. SPALLONE, E. RIGHI, G. TRENTA, G. D'AGOSTARO, P. QUERCIA, V. ANDREASSI, O. GIACINTI, P. MARINI, V. DI STEFANO, M. NAKAMURA, F. TODARELLO, E. PURCHI, A. MANCINI, P.G. SONA, F. FONTANA, L. GAMBERALE, D. GARBELLI, E. CELIA, F. FALCIONI, M. MARCHESINI, E. NOVARO, U. MASTROMATTEO. "*New procedures to make active, fractal-like, surfaces on thin Pd wires*". Proc. of 12th International Conference on Cold Fusion. 27 November-2 December 2005, Yokohama, Japan. Condensed Matter Nuclear Science series. World Scientific, pg. 377-403, (2006). ISBN 981-256-901-4 Invited Paper
- 44) A. SPALLONE, F. CELANI, P. MARINI, V. DI STEFANO "*Measurement of the temperature coefficient of electrical resistivity of Hydrogen overloaded Pd*". Proc. of 12th International Conference on Cold Fusion. 27 November-2 December 2005, Yokohama, Japan. Condensed Matter Nuclear Science series. World Scientific, pg. 404-410, (2006). ISBN 981-256-901-4
- 45) C. CATENA, D. POMPONI, G. TRENTA, F. CELANI, P. MARINI, G. DE ROSSI, V. TREMOLADA "*Acqua pesante (D₂O) irradiata: dal reattore nucleare alla cellula*" Fisica in Medicina, Vol.4, pg. 365-379 (2005). www.aifm.it
- 46) FRANCESCO CELANI, A. SPALLONE, P. MARINI, V. DI STEFANO, M. NAKAMURA, V. ANDREASSI A. MANCINI, E. RIGHI, G. TRENTA, E. PURCHI, U. MASTROMATTEO, E. CELIA, F. FALCIONI, M. MARCHESINI, E. NOVARO, F. FONTANA, L. GAMBERALE, D. GARBELLI, P.G. SONA, F. TODARELLO, G. D'AGOSTARO, P. QUERCIA. "*Electrochemical compression of Hydrogen inside a Pd-Ag thin wall tube, by alcohol-water electrolyte*". Proc. of 7th Meeting of Japan CF Research Society; April 27-28, 2006, Kagoshima University, Japan. Vol.7, pg. 38-46, (2006).
<http://wwwcf.elc.iwate-u.ac.jp/jcf/PAPER.HTML>
[http://www.lnf.infn.it/sis/preprint/pdf/getfile.php?filename=LNF-06-17\(P\).pdf](http://www.lnf.infn.it/sis/preprint/pdf/getfile.php?filename=LNF-06-17(P).pdf) **Invited Paper**
- 47) F. CELANI, A. SPALLONE, E. RIGHI, G. TRENTA, V. ANDREASSI, A. MARMIGI, P. QUERCIA, G. CAPPUCCIO, D. HAMPAL, P. MARINI, V. DI STEFANO, M. NAKAMURA, F. TODARELLO, E. PURCHI, A. MANCINI, P.G. SONA, F. FONTANA, L. GAMBERALE, D. GARBELLI, F. FALCIONI, M. MARCHESINI, DI BIAGIO, U. MASTROMATTEO "*High temperature Deuterium absorption in Palladium nano-particles*" Presented at 13th International Conference on Cold Fusion, June 24-July 2, 2007, Sochi (Russia) Submitted for publication by World Scientific. Preprint INFN-LNF 07/18 (P) September 19, 2007
[http://www.lnf.infn.it/sis/preprint/pdf/getfile.php?filename=LNF-07-18\(P\).pdf](http://www.lnf.infn.it/sis/preprint/pdf/getfile.php?filename=LNF-07-18(P).pdf) **Invited Paper**

4.4. Search for neutron emission from titanium deuterium systems

**CORRADO BORAGNO, ROBERTO EGGENHOFFNER,
PAOLO PRATI, GIOVANNI RICCO,
MAURO TAIUTI, UGO VALBUSA**

Genoa University – Physics Department

After the first claims about the so called “cold-fusion” phenomenon, we investigated possible neutron emission during high deuterium adsorption in titanium lattice. This activity has been conducted at the Department of Physics of the Genoa University in collaboration with the Genoa research units of INFN and INFN.

We designed and realized a multiparametric high-efficiency neutron detector in order to verify, with increased neutron detection sensitivity, the results reported by Scaramuzzi.

The neutron detector is reported in Figure 1. It is composed of three cylindrical coaxial scintillators shells. The inner shell is filled with NE213 liquid scintillator and the outer two are plastic NE102A. Cadmium sheets, 1 mm thick, are interposed between the scintillators to capture neutrons thermalized inside the detector. On top of the detector is located an anticoincidence scintillator to reduce the cosmic ray background. A 30 cm³ cylindrical sample can be inserted in the central hole.

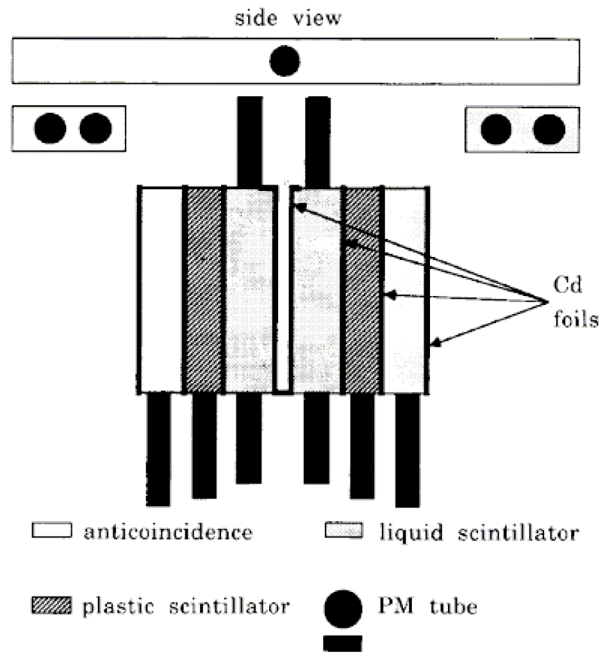

Fig. 1 – Detector geometry and composition.

The size of the detector is relatively larger compared to the mean free path of the few MeV neutrons expected from fusion reactions. The neutrons emitted from the central sample thermalize mainly in the liquid scintillator and diffuse in the detector till they are captured in the cadmium foils. A neutron event is identified by two signals, the first corresponding to a neutron-like pulse in the liquid scintillator and the second to the detection of a gamma following the capture of the neutron in the cadmium foils. A detailed description of the detection principles and data analysis is reported in Ref. 1.

The detection sensitivity, with a 3σ confidence level, was estimated equal to $2.4 T^{-1/2}$ neutrons/s, where T is the measurement time.

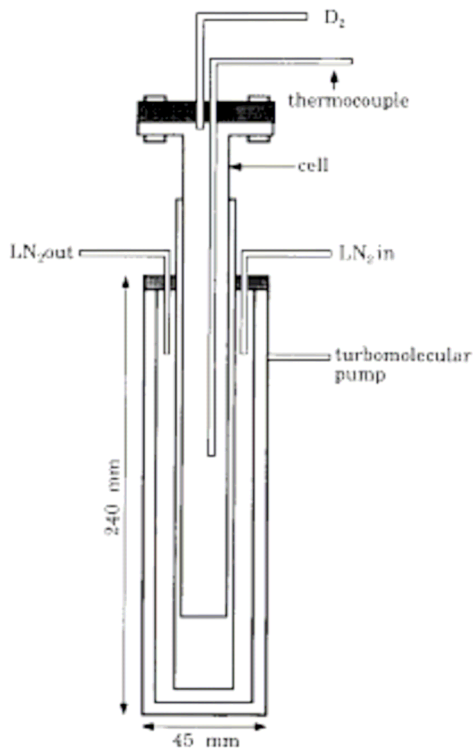

Fig. 2 – The titanium cell and the cryostat.

We have performed the measurements flowing deuterium gas in different titanium samples: shavings and powders. A drawing of the cell used in the experiments is shown in Figure 2. Great care was used to avoid thermal stresses on the neutron detector; for this reason high vacuum was continuously maintained in the external chamber.

More details on the measurements are reported in Ref. 2. We monitored the adsorption of deuterium and we obtained a deuterium-to-titanium ratio of 0.65. During the adsorption process we observed a rapid increasing of the temperature of the sample, but during all the measurements no neutron emission was detected. Therefore we did not find evidence of nuclear processes associated to the “cold fusion” phenomena and we were not interested to continue the investigation.

Bibliografia

1. G. RICCO, M. ANGHINOLFI, P. CORVISIERO, E. DURANTE, S. MAGGIOLO, P. PRATI, A. ROTTURA AND M. TAIUTI (1991) - *A Large Solid Angle Multiparameter Neutron Detector*. Nuclear Instruments and Methods in Physics Research 1991, Vol.A307, pp.374-379
2. P. PRATI, G. RICCO, M. TAIUTI, C. BORAGNO, R. EGGENHOFFNER AND U.VALBUSA (1992) - *Search for Neutron Emission from Titanium-Deuterium Systems*. Il Nuovo Cimento 1992, Vol.105A, N.2 pp.293-299

4.5. Research on the so-called “Cold Fusion” in Catania

MARCELLO BALDO
INFN - Catania

Experimental activity

In 1989 some researchers from the Catania INFN Unit and the Physics Department planned to perform an experiment following the so-called “Scaramuzzi” method. They were spurred by the curiosity about the possible existence of a new and unexpected phenomenon called “cold fusion”, which was the object of lively controversies both in the scientific literature and in seminars organized by prestigious national and international research laboratories (CERN, FRASCATI, LOS ALAMOS, RIKEN, SACLAY).

At Catania Physics Department a compression cell where Deuterium gas is compressed on a palladium target obtained by lamination (COLF reaction chamber) was set up, following the indications by experts on solid state from Catania University (Prof. P. Baeri, Prof. U. Campisano). In particular, they tried to highlight nuclear signals under transition-phase conditions of the Palladium structure. Identification systems for neutrons (NE213), gammas (BaF2) and charged particles (Si) were used, following the procedures and the typical experimental analyses of the experimental nuclear physics.

The prolonged observation of "thermal" and "compression" phases, where D_2 molecule concentration in Pd changed considerably, did not highlight neutron signals and gamma rays appreciably over the natural background. On the contrary, some signals were recorded in the charged particle detector.

The results were reported in an invited paper presented in the 1989 Varenna Conference, raising great interest and appreciation, and later published on a review specialized on fusion in general.

After this early phase of experiments, an original detection devise with ionization chamber and silicium was set up ex-novo. Then it was calibrated for the detection of very low energy protons through an α calibration source with three energy values and 2 MeV proton beam diffused on an Au target by using the Van De Graaff of Catania Physics Institute.

The detection system permitted to isolate a quite precise area of the DE-E matrix, drastically reducing the background, where “proton-like” events coming from the supposed $d+d \rightarrow p + t$ reaction were expected. Events compatible with proton detection and substantially confirming the previous analyses were isolated. Yet, the number of counts measured under “upper limit” conditions, evaluable by optimistic hypotheses – assuming that the background value was null in the energy area of the protons being examined – were incompatible (7 orders of magnitude lower) with the supposed “cold fusion” reaction, as shown by both Fleischmann (1989) and Scaramuzzi (1989).

Publications

1. S. AIELLO, P. BAERI, S.U. CAMPISANO, E. DE FILIPPO, G. FOTI, M.G. GRIMALDI, S. LO NIGRO, A. PAGANO AND L. TORRISI - “*Understanding Cold Fusion Phenomena*”. Editrice Compositori, SIF, Conference Proceedings Vol. 24, Eds. R.A. Ricci, E. Sindoni and F. De Marco, p. 273, Bologna 1989
2. S. AIELLO, E. DE FILIPPO, G. LANZANO’ E A. PAGANO - “*Nuclear Fusion Experiment in Palladium Charged by Deuterium Gas*”. Fusion Technology, 18, 115 (1990)

Theoretical activity

During the same years, some researchers of the theoretical group of Catania University and of the IV Group of Catania INFN Division studied the deuteron-plasmon interaction within a crystalline metal lattice, particularly Palladium, as the possible responsible for an induced deuteron-deuteron attraction sufficient for substantially increasing fusion probability. Such theory was later improved by Dr. M. Baldo, from the Catania INFN Division, and applied to the typical physical characteristics of Palladium.

The conclusion of such a theoretical elaboration is that plasmon-induced interaction can create a fusion “rate” compatible with the experimental data by Prof. Jones Group (I.S.E. Jones et al., Nature 338, 737 (1989)), but not with the data presented by M. Fleischmann and S. Pons (J. Electroanal. Chem. 261, 301 (1989)).

Publications

1. M. BALDO AND R. PUCCI - *Plasmon Enhance Fusion*. Editrice Compositori, SIF, Conference Proceedings, Vol. 24, Eds. R.A. Ricci, E. Sindoni and F. De Marco, p. 283, Bologna 1989.
2. M. BALDO, R. PUCCI AND P.F. BORTIGNON - *Relaxation Towards Equilibrium In Plasmon Enhanced Fusion*. Fusion Technology 18, 347 (1990).
3. M. BALDO - *Enhancement of Fusion Rate Induced by the Collective Electron Excitations*. Editrice Compositori, SIF, Conference Proceedings Vol. 33, Eds. T. Bressani, E. Del Giudice and G. Preparata, p. 187, Bologna 1991.

FULVIO FRISONE

Catania University – Physics and Astronomy Department

Dr. Fulvio Frisone is currently a researcher of the Physics Department of Catania University. He has carried out research on cold fusion for some years. He mainly supported the models of plasmon-induced fission and the so-called “microcracks”, and presented his conclusions in some articles and in many Conference reports.

Further details on Dr. Fulvio Frisone’s activity can be found at the website: <http://www.lombardoconsultspa.org/fulviofrisone/>

Publications

1. *Study on the Probability of Interaction Between The Plasmons of Metal and Deuterons*. Published by the Scientific Review "Il Nuovo Cimento", vol.18 D, n.11 of November 1996.
2. *Can Variations in Temperature Influence Deuteron Interaction within Crystalline Lattices*. The Scientific Review "Il Nuovo Cimento" vol.20 D, n.10, pp.1567-1580, of October 1998.
3. *"Deuteron Interaction within a Microcrack in a Lattice at Room Temperature"*. Fusion Thecnology. Vol.39 n.2, pp.260-265, March 2001
4. *Theoretical Model of the Probability of Fusion Between Deuterons within Deformed Crystalline Lattices with Microcraks at Room Temperature*. Fusion Thecnology. Vol. 40 n.2, pp.139-146, September 2001
5. *Manuale della Materia coerente verso la Fusione Fredda*, 2006

Conference Contributions

Workshop on "*Anomalies in Hydrogen/Deuterium Loaded Metals*"- Asti November 26-30, 1997, where he presented a scientific contribution entitled: "Theoretical Hypothesis of the Phenomenon of Nuclear Cold Fusion", contained in the following publications:

"Conference Proceedings - Asti Workshop on Anomalies in Hydrogen/Deuterium Loaded Metals".

Scientific Review "Infinite Energy - Cold Fusion and New Energy Technology" Vol. 03, n.17, December 1997-January 1998

Scientific Review "New Energy News" vol. 05, n.09, January 1998

7th International Conference on "*Cold Fusion*" – Vancouver, Canada, April 19-25, 1998, where he presented a scientific contribution entitled: "*Can Impurities within a Deuterated Crystalline Lattice have an Effect Favouring Cold Fusion?*", contained in the conference publication with the following title: "ICCF-7 Vancouver - The Best Ever!".

ENEA Workshop held in Frascati on May 28-29, 1998, on: "New Energy From Hydrogen".

85th National SIF Conference – Pavia, September 20-24, 1999. He presented a scientific contribution entitled: "*Confronto tra due Modelli Teorici sulla Interazione fra Deuteroni in Reticoli Cristallini*", contained in the conference publication with the following title: "LXXXV Congresso Nazionale Società Italiana di Fisica".

7th Russian International Conference on Cold Fusion and Nuclear Transmutation - RCCNT-7" - SOCHI (Russia) September 25 – October 3 1999 organized by: "Russian Academy of Sciences", "Russian Physical Society", "Nuclear Society of Russia", "Russian Mendeleev Chemical Society", "Moscow Lomonosov State University", "Russian Peoples Friendship University", "State Technical University (Madi)" and "Russian Committee on Ball Lightning". He presented a scientific contribution entitled: "*The Effects of Impurities and Variations in Temperature on the Interaction of Deuterons in Three - Dimensional Crystalline Lattices*", contained in the conference publication with the following title : "Cold Nuclear Transmutations - Proceedings of the 7th Russian Conference on Cold Nuclear Transmutations of Chemical Elements".

6th CRRNSM Triennial Scientific Conference – Palermo, October 14-15, 1999. He presented a scientific contribution entitled: "*Fusion Reaction within a Microcrack in a Crystalline Lattice at Room Temperature*", contained in the conference publication with the following title: "Nuclear and Condensed Matter Physics" edited by AIP - American Institute of Physics".

Conference on "*The Nuclear Interaction: World Motor*" - Fiumefreddo (Sicily) on August 6, 1999 on the occasion of "POSIDONE 1999".

4th Asti Workshop – October 21-25, 1999. He presented a scientific contribution entitled: "*Calculation of Deuteron Interactions within Microcrack of a D2 Loaded Crystalline Lattice at Room Temperature*", contained in the conference publication.

8th International Conference on *Cold Fusion* - Lerici (Italy) May 21-26, 2000. He presented a scientific contribution entitled: "*Probability of Deuteron-Plasmon Fusion at Room Temperature within Microcracks of Crystalline Lattices with Deuterium Loading*", contained in the conference publication with the following title: "ICCF8 Proceedings of the 8th International Conference on Cold Fusion".

8th Russian International Conference on "*Cold Fusion and Nuclear Transmutation' Rccnt-8*" SOCHI (Russia) October 3-11, 2000, organized by: "Russian Academy of Sciences", "Russian Physycal Society", "Nuclear Society of Russia", "Russian Mendeleev Chemical Society", "Moscow Lomonosov State University", "Russian Peoples Friendship University", "State Technical University (Madi)", "Research Institute of High Temperatures" and "Russian Committee on The Problems of Ball Lightning". He presented a scientific contribution entitled: "*Theoretical Hypothesis on the Correlation between the Probability of Fusion on the Surface and within Microcracks of a Deuterium Loaded Crystalline Lattice at Room Temperature*", contained in the conference publication with the following title: "Cold Nuclear Transmutations - Proceedings of the 8th Russian Conference on Cold Nuclear Transmutations of Chemical Elements".

86th National SIF Conference " – Palermo October 6-11, 2000. He presented a scientific contribution entitled: "*Studio della Reazione di Fusione in una Microfrattura a Temperatura Variabile*", contained in the conference publication with the following title: "LXXXVI Congresso Nazionale Società Italiana di Fisica".

9th Russian Conference on Cold Fusion and Nuclear Transmutation" SOCHI (Russia), September 30-October 7, 2001 organized by: "Russian Academy of Sciences", "Russian Physycal Society", "Nuclear Society of Russia", "Russian Mendeleev Chemical Society", "Moscow Lomonosov State University", "Russian Peoples Friendship University", "State Technical University (Madi)", "Research Institute of High Temperatures" and "Russian Committee on The Problems of Ball Lightning". He presented a scientific contribution entitled: "*Cold Fusion Reaction within a Microcrack With Cfc Lattice Structure at Low Energy and Study of the Non Semi-Classic Tunneling Effect*", contained in the conference publication with the following title: "Cold Nuclear Transmutations - Proceedings of the 9-th Russian Conference on Cold Nuclear Transmutations of Chemical Elements".

Scientific Conference - Collesano (PA) October 31, 2001 on Cold Fusion entitled: "*Ipotesi Teorica sul Fenomeno d'Interazione Plasmone-Deuterone*".

dentro Micro-Crack a Temperatura non costante e Calcolo dell'Effetto Tunneling con Energia Diversa da Costante".

9th International Conference on "Cold Fusion" - Beijing (China) May 19-24, 2002. He presented a scientific contribution entitled: "*Theoretical Model on the Relationship Between Low Energies in the Probability of Deuterium Nuclei Cold Fusion*", contained in the conference proceedings.

The scientific review "*Infinite Energy*", vol.08, n.46, 2002, pp.63-70, published an article entitled: "Comparison Between two Theoretical Models for Deuteron-Plasmon Interaction with Enhanced Tunneling Effect".

11th International Conference on Emerging Nuclear Energy System - Albuquerque, New Mexico, USA, September 29-October 4, 2002. He presented a scientific contribution entitled: "*Theoretical Analysis of the Cold Fusion Process*", contained in the conference publication with the following title: "ICENES 2002 – Proceedings".

2003 International Conference on Advances in Nuclear Power Plants - ICAPP '03" - Cordoba (Spain), May 4-7, 2003. He presented a scientific contribution entitled: "*Calculation Of Deuteron Interactions within Microcracks of a D₂ Loaded Crystalline Lattice at Room Temperature*", contained in the Conference "Proceedings" that will be published soon.

10th International Conference on Cold Fusion (ICCF-10) - Boston (USA), August 24-29, 2003. He presented a scientific contribution: "*Fusion Reaction within a Microcrack with Cfc Lattice Structure at Low Energy and Study of the non Semi-Classic Tunneling Effect*", that will be contained in the conference proceedings.

Catania Physics Department – September 4, 2003. He promoted a Seminar on "Interaction within solids" entitled: "*L'interazione dentro i Reticoli in Funzione delle Condizioni Termodinamiche e Studio dell'Effetto Tunneling*".

11th Russian Conference on Cold Nuclear Transmutation of Chemical Elements and Ball-Lightning (RCCNT&BL-11)" - Sochi (Russia) September 28–October 5, 2003. He presented a scientific contribution entitled: "*Correlation Between the Probability of Fusion on the Lattice Surface and within Microcracks at Room Temperature and Low Energy*", that will be contained in the conference proceedings.

Many Body System 2003 (MBS 2003) - Catania (Italy), Physics Department October 6-8, 2003. He presented a scientific contribution entitled: "*Qed Coherence in Cold Fusion*".

5th Asti Workshop on Anomalies in Hydrogen/Deuterium loaded Metals - Asti (Italy) March 19-21, 2004. He presented a scientific contribution entitled: "*Coherence Qed in Cold Fusion whitin Microcracks of a D₂O Loaded Lattice Deformation at Room Temperature*".

AUGUSTO SCALIA

Catania University- Physics and Astronomy Department

The “shadow” model in nuclear fusion

The nuclear reactions at very low energies are of interest because they are involved in the primordial nucleosynthesis of the light elements in the early universe, moreover the values of nuclear cross section adopted in the calculations of reaction rates are relevant to obtain the neutrino fluxes by using stellar evolution codes. The nuclear fusion processes at very low energies are, also, of interest in the framework of the cold fusion process. During the last years we investigated the fusion process at sub-barrier energies by performing a phenomenological analysis. A new model

was suggested: the “shadow” model. In this model the fusion process is considered as the shadow

of the Rutherford scattering, so that the particles which fuse are those that in the Rutherford scattering are detected in the “shadow” region. By using this point of view a regularity was found by analysing fusion data relative to systems with $2 < A_1 + A_2 < 184$. A new analytical expression for the fusion cross section was obtained. The “shadow” model is based on this observed regularity and is able to reproduce the experimental values of fusion cross section for about 100 reactions at energies below the Coulomb barrier. The fusion cross sections so obtained depend on two parameters which are energy independent and which are different for different reactions. These parameters are connected with the Coulomb barrier energy. It is possible, also, to show that the ratio between the experimental values of fusion cross section and a suitable geometrical cross section is a universal function. The “shadow” model can be used to obtain the “reaction rate” in the nuclear astrophysics and in cold fusion processes at energy very below the Coulomb barrier.

We note, also, that experimental measurements revealed that the fusion cross sections at very low energies are noticeably higher than those expected from the extrapolated energy dependence of the measured cross sections at higher energies. Generally it is assumed that this fact is due to electron screening, but the screening potential necessary to fit experimental data is significantly larger than those expected from available atomic physics models. By using the “shadow” model this enhancement can be obtained and it is due to a nuclear effect.

Publications

1. *The interaction time for heavy-ion fusion*, Il Nuovo Cimento A 92, 210 (1986)
2. *The heavy-ion fusion in terms of the Rutherford trajectories*, Il Nuovo Cimento A 94, 88 (1986)
3. *The fusion time by using the “elastic” model*, Proceedings of the Symposium on “The many facets of heavy-ion fusion reactions”, Argonne National Laboratory, USA (1986)
4. *A simple approach to sub barrier fusion*, Proceedings of the “Secondo Convegno su Problemi di Fisica Nucleare Teorica”, Cortona, Italy (1987)
5. *The sub barrier fusion with the elastic model*, Il Nuovo Cimento A 98, 517 (1987)
6. *A Energy dependent nucleus-nucleus potential from the elastic model*, Il Nuovo Cimento A 98, 589 (1987)
7. *Sub barrier fusion using the Rutherford scattering*, Proceedings of the Texas A&M Symposium on “Hot Nuclei”, College Station, Texas (1987)
8. *Heavy-ion fusion in nuclear astrophysics*, Memorie della Società Astronomica Italiana (Journal of the Italian Astronomical Society), Vol. 60, n. 1-2 (1989)
9. *The reaction rate in nuclear fusion*, Il Nuovo Cimento A 100 (1988)
10. *A new approach to heavy-ion fusion*, Il Nuovo Cimento A 101, 781 (1989)
11. *The nuclear fusion for the reactions ${}^2\text{H}(d,n){}^3\text{He}$, ${}^2\text{H}(d,p){}^3\text{H}$* , Il Nuovo Cimento A 101, 795 (1989)
12. *The nuclear fusion for the reactions ${}^2\text{H}(d,n){}^3\text{He}$, ${}^2\text{H}(d,p){}^3\text{H}$ at low energy*, Il Nuovo Cimento A 102, October (1989)
13. *The nuclear fusion for the reaction ${}^3\text{H}(d,n){}^4\text{He}$ at very low energy*, Il Nuovo Cimento A 102, October (1989)
14. *A new approach to heavy-ion fusion II: systematic comparison with experimental data*, in coll. con R. GIORGANO, S. SAMBATARO, F. PORTO, P. FIGUERA, S. PIRRONE, Il Nuovo Cimento A 103, 47 (1990)
15. *The extended elastic model applied to the reaction ${}^3\text{He}(d,\gamma){}^7\text{Be}$* , Il Nuovo Cimento A 103, 213 (1990)

16. *The extended elastic model applied to the reaction ${}^3\text{He}({}^3\text{He}, 2p) {}^4\text{He}$* , Il Nuovo Cimento A 103, 85 (1990)
17. *The nuclear fusion for the reaction ${}^3\text{He}(d,p) {}^4\text{He}$* , Il Nuovo Cimento A 103, 255 (1990)
18. *The extended elastic model II applied to the reaction ${}^2\text{H}(\alpha, \gamma){}^6\text{Li}$* . Il Nuovo Cimento A 103, 927 (1990)
19. *The reaction rate at $T \sim 300$ °K for the reactions ${}^2\text{H}(p, \gamma){}^3\text{He}$, ${}^2\text{H}(d,p){}^3\text{H}$, ${}^2\text{H}(d,n){}^3\text{He}$, ${}^3\text{H}(d,n){}^4\text{He}$, ${}^3\text{He}(d,p){}^4\text{He}$, ${}^2\text{H}(\alpha, \gamma){}^6\text{Li}$, ${}^3\text{He}({}^3\text{He}, 2p){}^4\text{He}$, ${}^3\text{H}(\alpha, \gamma){}^7\text{Be}$* , Il Nuovo Cimento A 102, 953 (1989)
20. *A new approach to heavy-ion fusion III: an extension to systems with large mass asymmetry*, in coll. Con R. GIORDANO, S. SAMBATARO, F. PORTO, P. FIGUERA, S. PIRRONE, Il Nuovo Cimento A 103, 269 (1990)
21. *The nuclear fusion for the reaction ${}^3\text{H}(d, n){}^4\text{He}$* , Proc. Int. Nuclear Physics Conference San Paulo, Brasil (1989)
22. *The nuclear fusion for the reaction ${}^3\text{H}(\alpha, \gamma){}^7\text{Be}$* , Il Nuovo Cimento A 103, 1177 (1990)
23. *The nuclear fusion for the reactions ${}^2\text{H}(p, \gamma){}^3\text{He}$, ${}^2\text{H}(d,p){}^3\text{H}$, ${}^2\text{H}(d,n){}^3\text{He}$, ${}^3\text{H}(d,n){}^4\text{He}$, ${}^3\text{He}(d,p){}^4\text{He}$, ${}^2\text{H}(\alpha, \gamma){}^6\text{Li}$, ${}^3\text{He}({}^3\text{He}, 2p){}^4\text{He}$, ${}^3\text{H}(\alpha, \gamma){}^7\text{Be}$* , Proc. III Convegno su Problemi di Fisica Nucleare Teorica, Cortona, Italy (1989)
24. *The extended elastic model II applied to the reactions ${}^2\text{H}(d, n){}^3\text{He}$, ${}^2\text{H}(d, p){}^3\text{H}$* , in coll. with R. GIORDANO, P. FIGUERA, S. PIRRONE, Il Nuovo Cimento A (short notes) 103, 465 (1990)
25. *The extended elastic model III: the nuclear fusion for the reaction ${}^7\text{Li}(p, \alpha){}^4\text{He}$* , Il Nuovo Cimento A 104, 563 (1991)
26. *An effective Coulomb potential obtained by using the extended elastic model III for the sub-barrier fusion*, Il Nuovo Cimento A 104, 707 (1991)
27. *An effective strong interaction distance obtained in the framework of the extended elastic model III for the sub-barrier fusion*, Il Nuovo Cimento A 104, 713 (1991)
28. *A simple expression for the cross section factor in nuclear fusion*, Il Nuovo Cimento A 104, 691 (1991)

29. *The sub-barrier fusion as the shadow of elastic scattering*, Il Nuovo Cimento A 104, 1467 (1991)
30. *Interaction time for sub-barrier fusion*, Il Nuovo Cimento A 104, 1441 (1991)
31. *The “shadow” model for the sub-barrier fusion*, Il Nuovo Cimento A 105, 233 (1992)
32. *“Shadow” model for the sub-barrier fusion applied to light systems: determination of the reaction rate*, in coll. with P. FIGUERA, Phys. Rev. C, 46, 2610 (1992)
33. *The cross section factor for the reactions ${}^2\text{H}(d, n){}^3\text{He}$, ${}^2\text{H}(d, p){}^3\text{He}$ at very low temperature*, in coll. with P. FIGUERA, Proc. II Annual Conference on cold fusion (ACCF2), Como, Italy (1991)
34. *“Shadow” properties in sub-barrier fusion*, Phys. Rev. C, 47, 1247 (1992)
35. *The fusion process by using the “shadow model”*, Proc. Int. School-Seminar on “Heavy Ion Physics”, May 10-15, Dubna, Russia (1993)
36. *New sub-barrier nuclear fusion cross section as possible solution of the solar neutrino problem*, in coll. with L. PATERNÒ, Proc. Seventh European Meeting on Solar Physics “Advances in Solar Physics”, May 11-15, Catania, Italy (1993). Lectures Notes in Physics, Springer-Verlag, Berlin, Vol. 432, 41 (1994)
37. *“Door” energies in sub-barrier fusion at very low energy*, Il Nuovo Cimento A 106, 855 (1993)
38. *Reply to Comment on “Shadow” model for sub-barrier fusion applied to light systems*, Phys. Rev. C, 49, 284 (1994)
39. *The “Shadow” model for the sub-barrier fusion: determination of the reaction rates in nuclear astrophysics*, Proc. Winter School held at Folgaria, Italy (1994)
40. *S-factor in the framework of the “Shadow” model*, Proc. Third Int. Symposium on Nuclear Astrophysics “Nuclei in the Cosmos”, Gran Sasso, Italy (1994)
41. *Fusion process and elastic scattering for the $p+{}^{12}\text{C}$ system at energy below the coulomb barrier*, in coll. con N. ARENA, S. CAVALLARO, R. GIORDANO, Proc. Int. Symposium on “Large-Scale Collective Motion of Atomic Nuclei”, Brolo, Italy (1996)

42. *Fusion process and elastic scattering for the system $p+^{12}C$* , in coll. con N. ARENA, S. CAVALLARO, R. GIORDANO, Proc. Fourth Int. Conference on “Nuclei in the cosmos”, Notre Dame, Indiana, USA (1996)
43. *Fusion process and elastic scattering at energies around and below the Coulomb barrier*, in coll. con N. ARENA, S. CAVALLARO, R. GIORDANO, Proc. VI International School-Seminar on “Heavy Ion Physics”, Dubna, Russia (1997)

Conference Contributions

1. *The fusion time by using the “elastic” model*, Proc. Symposium on The Many Facets of Heavy-ion Fusion Reaction, Argonne National Laboratory, USA (1986)
2. *The fusion time by using the “elastic” model*, Proc. Int. Conference on Heavy-ion Nuclear Collision in the Fermi Energy Domain. Caen, France (1986)
3. *A simple approach to sub barrier fusion*, Proc. Secondo Convegno su Problemi di Fisica Nucleare Teorica, Cortona, Italy (1987) Oral Presentation
4. *Sub barrier fusion using the Rutherford scattering*, Proc. Of the Texas A&M Symposium on Hot Nuclei, College Station, Texas, USA (1987)
5. *Heavy-ion fusion in nuclear astrophysics*, XXXII Congresso Nazionale SAIT, Catania, Italy (1988) – Oral Presentation
6. *The sub barrier fusion and the Rutherford scattering*, Proc. Symposium on Heavy Ion Interaction around the Coulomb Barrier, Legnaro, Italy (1988)
7. *The sub barrier fusion in terms of the Rutherford trajectories*, Proc. Third International Conference on Nucleus-Nucleus Collisions, Saint Malo, France (1988) – Poster presentation
8. *The heavy-ion fusion above the barrier described by a new approach*, in coll. con R. Giordano, S. Sambataro, F. Porto, P. Figuera, S. Pirrone, Proc. Int. Nuclear Physics Conference, Sao Paulo, Brasil (1989) – Poster Presentation
9. *The nuclear fusion for the reaction $^3H(d, n)^4He$* , Proc. Int. Nuclear Physics Conference, Sao Paulo, Brasil (1989) – Oral Presentation
10. *The reaction rate for light systems bu using the extended elastic model III*, Proc. Fourth International Conference on Nucleus-Nucleus collision, Kanazawa, Japan (1991) – Poster Presentation

11. *The cross section factor for the reaction ${}^2\text{H}(d, p){}^3\text{H}$, ${}^2\text{H}(d, n){}^3\text{He}$ at very low temperature*, in coll. con P. FIGUERA, Proc. II Annual Conference on Cold Fusion (ACCF2), Como, Italy (1991) – Oral Presentation
12. *The sub-barrier fusion process obtained as the “shadow” of elastic scattering*, Proc. Int. Nuclear Physics Conference, Weisbaden, Germany (1992)
13. *The fusion process by using the “shadow model”*, Proc. Int. School-Seminar on “Heavy Ion Physics”, Dubna, Russia (1993) – Oral Presentation
14. *New sub-barrier nuclear fusion cross section as possible solution of the solar neutrino problem*, in coll. con L. PATERNÒ, Proc. Sventh European Meeting on Solar Physics “Advances in Solar Physics”, Catania, Italy (1993) – Oral Presentation
15. *The “Shadow” model for the sub-barrier fusion: determination of the reaction rates in nuclear astrophysics*, Proc. Winter School held at Folgaria, Italy (1994) – Invited Talk
16. *Elastic scattering for the system $p+{}^{12}\text{C}$ at low energy*, in coll. con N. ARENA, S. CAVALLARO, R. GIORDANO, Proc. Fifth Conference on Nucleus-Nucleus Collisions, Taormina, Italy (1994) – Poster Presentation
17. *Nuclear fusion for the system $p+{}^7\text{Be}$ at very low energy*, Proc. Fifth Int. Conference on Nucleus.Nucleus Collision, Taormina, Italy (1994)
18. *Nuclear fusion for the reaction ${}^3\text{H}+{}^4\text{He}$ at very low energy*, Proc. Workshop on “Heavy-ion fusion: exploring the variety of nuclear properties”, Padova, Italy (1994)
19. *S-factor in the framework of the “Shadow”model*, Proc. Third Int. Symposium on Nuclear Astrophysics “Nuclei In the Cosmos”, Gran Sasso, Italy (1994) – Poster Presentation
20. *Nuclear fusion for the system ${}^3\text{H}+{}^3\text{He}$ at very low energy*, IV Conference on Selected Topics in Nuclear Structure, Dubna, Russia (1994)
21. *Elastic scattering and fusion process for the system $p+{}^{12}\text{C}$* , Proc. Int. Nuclear Physics Conference, Beijing, China (1995) – Poster Presentation

22. *Astrophysical $S(E)$ -factor at very low energy: screening effect or nuclear effect?*, Proc. Int. Nuclear Physics Conference, Beijing, China (1995) – Poster Presentation
23. *Astrophysical $S(E)$ -factor at very low energy: screening effect or nuclear effect.* Proc. Joint European and National Astronomy Meeting JENAM-95, Catania, Italy (1995) – Poster Presentation
24. *Astrophysical $S(E)$ -factor at very low energy: screening effect or nuclear effect?*, Proc. Gourth Int. Conference on “Nuclei in the Cosmos” Notre Dame, Indiana, USA (1996) – Oral Presentation
25. *Fusion process and elastic scattering at low energy for the $p+^{12}C$ system*, Proc. Fourth Int. Conference on “Nuclei in the Cosmos”, Notre Dame, Indiana, USA (1996) – Poster Presentation
26. *Astrophysical $S(E)$ -factor below the Coulomb barrier at very low energy: screening effect or nuclear effect?*, Proc. Int. Symposium on “Large-Scale Collective Motion of Atomic Nuclei”, Brolo, Italy (1996) – Poster Presentation
27. *Fusion process and elastic scattering for the $p+^{12}C$ system at energy below the Coulomb barrier*, Proc. Int. Symposium on “Large-Scale Collective Motion of Atomic Nuclei”, Brolo, Italy (1996), in coll. con N. ARENA, S. CAVALLARO, R. GIORDANO - Oral Presentation
28. *Elastic scattering for light systems at very low energy*, Proc. 6th Int. Conference on Nucleus-Nucleus Collisions, Gatlinburg, Tennessee, USA (1997), in coll. con N. ARENA, S. CAVALLARO, R. GIORDANO – Poster Presentation
29. *Fusion process for light systems at very low energies*, Proc. 6th Int. Conference on Nucleus-Nucleus Collisions, Gatlinburg, Tennessee, USA (1997) – Poster Presentation
30. *Fusion process and elastic scattering at energies around and below the Coulomb barrier*, Proc. VI School-Seminar on Heavy Ion Physics, Dubna, Russia (1997) in coll. con N. Arena, S. Cavallaro, R. Giordano – Oral Presentation
31. *A new method to determin the Energy of the Coulomb barrier by using experimental fusion data*, Proc. Second OAK Ridge Symposium on Atomic and Nuclear Astrophysics, OAK Ridge, Tennessee (1997) – Poster Presentation

32. *Phenomenological analysis of nuclear fusion process for systems with $62 \leq A1 + A2 \leq 184$* , Proc. Int. Nuclear Physics Conference, Paris, France (1998)
33. *Phenomenological analysis of nuclear fusion process for systems with $62 \leq A1 + A2 \leq 184$* , Proc. Int. Symposium on Nuclear Astrophysics “Nuclei in the Cosmos”, Volos, Greece (1998) – Poster Presentation

4.6. Pd Systems Loaded with D₂ and H₂ Gases and Irradiated by Laser Beams

ANTONELLA LORUSSO E VINCENZO NASSISI
Lecce University – Physics Department

Introduction

Research on Cold Fusion at LEAS laboratory starts after the publication of the surprising experimental results achieved by Fleischmann e Pons [1] in 1989.

The method of D₂ or H₂ gas loading of Pd samples was preferred to the traditional electrolytic loading since the metal-gas system is much more simple to monitor and it implies cleaner work conditions [2].

LEAS laboratory interest in research was mainly focused to enhance the loading conditions of metal-gas systems by building specific stainless steel chambers. Inside these chambers Pd samples were loaded by changing opportunely the working conditions. The first achieved results were not published where the detection of elements different from Pd were found on the surface of the Pd samples subjected to gas loading. These results were not ascribable to possible transmutation processes, but rather to bad manipulations made during the experiment.

Later on, on the contrary, the possibility of transmutation processes in the studied systems was confirmed. Hence the research work on Cold Fusion increased and an attempt for improving gas absorption in palladium was made by utilizing the localization process through an ultraviolet radiation [3]. Indeed, it is known that the UV radiation favours multiphotonic absorption processes and the gas localization within crystalline lattices.

In the early phase of our work, we used palladium bulk samples loaded with D₂ or H₂ and laser-treated, while in the second phase, we treated palladium films having different thickness and laser-treated [4, 5]. At the end of the treatment, the samples were analyzed by the different SEM, EDX, ICP-OES techniques in order to evaluate the existence of “new elements”.

A possible explanation for this phenomenon is ascribable to nuclear fusion processes even if the overall system temperature and the thermal energy produced are very low.

However, the structure of the condensed matter formed in metal-gas systems is very complex and the consequences of the collective action of the atoms involved is not well-known yet.

In our experiments the existence of new elements has been observed only in limited areas of the sample surface looking like film grains and bulk holes. These considerations lead to call for the collective phenomena in order to justify the experimental results. As a matter of fact, they could introduce a high interaction probability amongst the particles due to coherent oscillations of metal electrons (plasmons) [6].

The interaction probability could even increase due to the phonon distribution, which separates the positive charges from the negative ones, thus generating free electrons in such a condition that it could be accelerated. In this way, nuclei can gain kinetic energy thus exceeding the Coulomb barrier and consequently generating nuclear fusion processes [7].

The phenomenon could be also explained by the Pd-D or Pd-H crystalline lattice deformation which would increase the interaction probability at least 2-3 orders of magnitude if compared to the one occurring in the case of fusion on the lattice surface[8].

Experimental Apparatus and Results

Bulk samples

Bulk samples are pure (99.95%) palladium disks characterized by 8 mm diameter, 0.5 mm thickness and 0.3 gr weight. To perform the experiments, two stainless steel chambers were used. They were cylindrical with a 4cm internal diameter and 20 cm long. The ends were closed by two quartz windows allowing laser beams to irradiate the samples. Each chamber is connected to a vacuum system by way of two 6mm inlet tubes allowing also the gas input. Fig. 1 shows the chamber scheme.

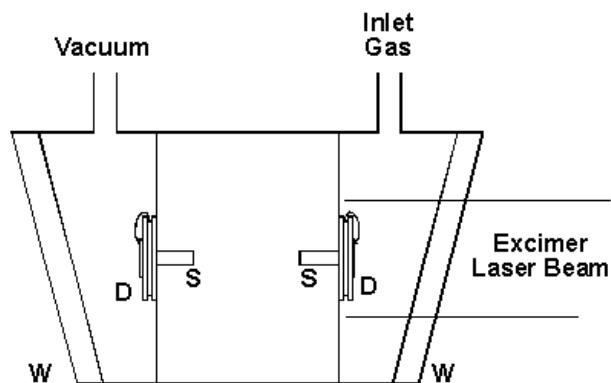

Fig. 1 – Scheme of the chamber containing Pd samples. S: Sample holders; W: Quartz windows; D: Samples

The samples were fixed inside the chamber by an aluminium support and a stainless steel spring, avoiding the use of adhesive pastes in order to reduce the possible contaminations. Only one of the two inserted samples was laser-irradiated thus allowing to compare the results with the non-irradiated sample.

Before beginning the experiments, the chambers were carefully cleaned with acetone and dried with nitrogen. Then they were closed and emptied by means of a cascade turbomolecular rotary pump, achieving a vacuum of approximately 10^{-5} mbar.

The system used allowed to carry out all possible combinations related to D_2 or H_2 loading and to the treatment by laser. The laser was applied, after the gas input into the chambers, every 15 days, 7 runs. The amount of laser shots per run was of 500 shots with an energy density of approximately 100 mJ/cm^2 . The samples were examined after 3500 laser irradiation shots.

The used excimer laser was operated at 308 nm (photon energy of 4.02 eV) with a 20 ns time duration. It is known, in fact, that UV irradiation favours the multiphotonic absorption process favouring the localization of gas atoms within the host metal. After 115 days, the chambers were opened and the treated samples, along with the air-exposed control samples, were analyzed by SEM, EDX e ICP-OES techniques to study the morphological and chemical characteristics of their surface. The morphologic analysis shows the formation of small craters and caverns in the loaded samples.

Gas	Irradiated	Elements found	Number of craters and caverns/mm²
<i>H₂</i>	<i>No</i>	<i>Al, Si, S, Cl, Fe, Cd, Pt</i>	<i>1200</i>
<i>H₂</i>	<i>Yes</i>	<i>Na, Mg, Al, Si, S, Fe, Zn</i>	<i>1600</i>
<i>D₂</i>	<i>Yes</i>	<i>Al, Si, S, Cr, Fe, Pt</i>	<i>1600</i>
<i>D₂</i>	<i>No</i>	<i>Mg, Al, Si, Ti</i>	<i>1200</i>

Table I - Experimental results achieved with Pd bulk samples

Their concentration was of about 1200 and 1600 per mm² for the non-irradiated and the irradiate samples respectively. Approximately 20 spot distributed all over the sample were examined, and the following common elements were found: Al and Si for the non-laser-irradiated samples while Al, Si, S and Fe for the irradiated samples. Table 1 summarizes the achieved results.

The evident presence of many elements with atomic number lower than Pd's, it suggests that the processes on which this phenomenon is based could be originated from nuclear fission processes as asserted by the RIFEX theory [7].

Film samples

Film sample measurements were made by using Pd thin films deposited on Si wafers (100) obtained through thermal evaporation, with a surface of about 1 cm² and thickness of 16, 35, 50, 83, 90, 106, 125 and 141 nm. The Pd films were inserted in the stainless steel chambers with deuterium at a pressure of 2.4 and 5 bar and were treated for five weeks with 500 laser shots each day. The laser fluence was chosen of 25 mJ/cm² in order to avoid spoiling of the Pd film. After the film treatment, it was observed that the films lost its smoothness and grains formed on it (Fig. 2). Such grains contained a great number of elements which were absent in the control samples. The grain distribution as well as the formation of new elements increased as the film thickness increasing, as shown in Fig. 3, regardless of the sample treatment conditions. The thickest films were found to have the following new common elements for all different treatment conditions: Na, S, Cl, Ca, Al.

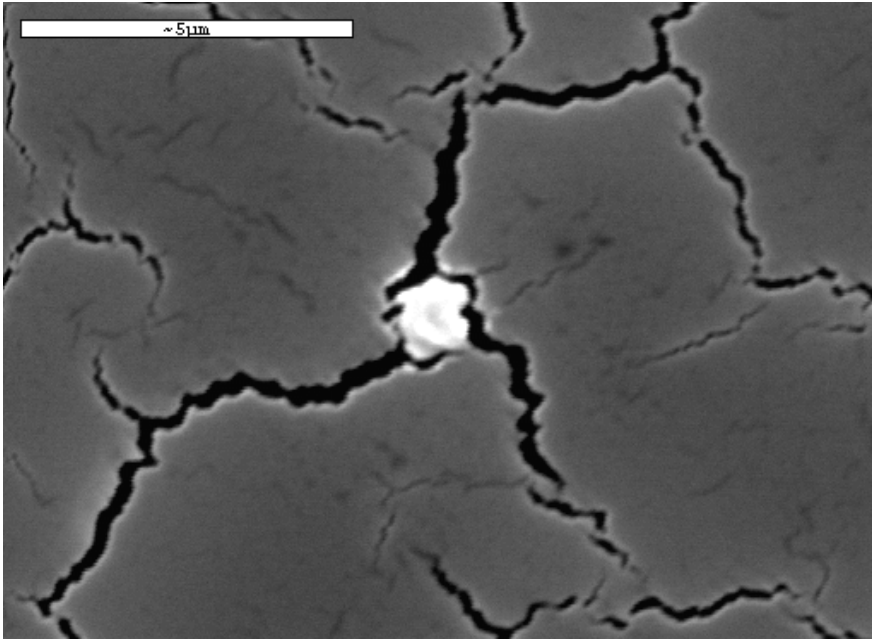

Fig. 2 - SEM Image of a grain present on the Pd film surface

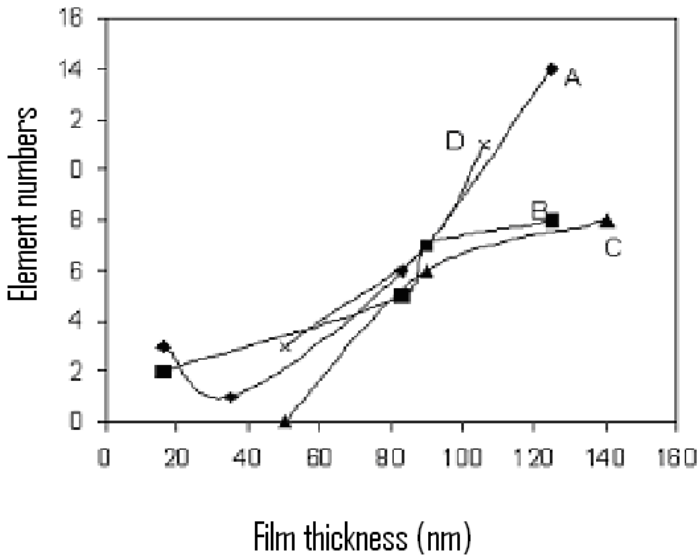

Fig. 3 - Number of "new elements" as a function of Pd film thickness.
 Case A: films loaded with D_2 at 2.4 bar; case B: films loaded with D_2 at 2.4 bar and irradiated; Case C: films loaded with D_2 at 5 bar;
 Case D: films loaded with D_2 at 5 bar and irradiated

Measurements on pressure trend over time

Pd transmutation in different elements and other effects due to cold fusion could be the consequence of the high absorption power of metal with respect to H₂ and D₂.

In order to study the gas absorption trend over time, an opportunely chamber made of stainless steel was built containing a Pd bulk sample at an initial H₂ pressure of about (1.17±0.05) bar. The pressure trend is shown in Fig. 4.

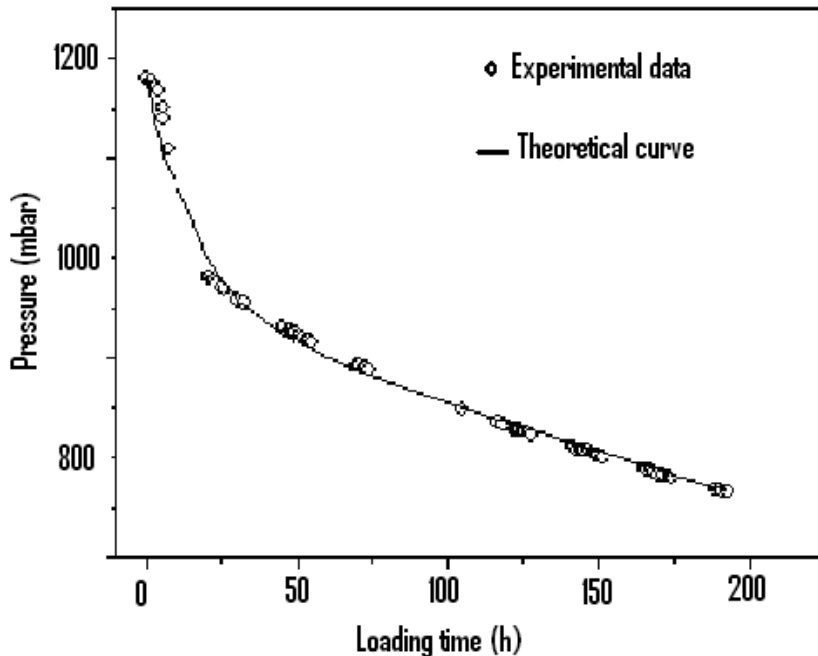

Fig. 4 - Pressure trend as a function of time

As it may be observed in Fig. 4, the decreasing of chamber pressure in the first 20 hours of absorption indicates a prompt gas absorption. Then pressure decreases more gradually, probably depending on the fact that diffusivity is related to the gas concentration within the bulk as well as to the sample volume.

The experimental data about the absorption trend as a function of time follows the theoretical curve given by the sum of two exponentials:

$$A \exp(-t / \tau) + B \exp(-t / \beta)$$

where A and B are two arbitrary constants, while τ and β are time constants of value equivalent to:

$$A = 235 \text{ mbar}$$

$$\tau = 20 \text{ hours}$$

$$B = 940 \text{ mbar}$$

$$\beta = 960 \text{ hours}$$

References

1. M. FLEISCHMAN AND S. PONS, *J. Electroanal. Chem.* 261, 301 (1989).
2. S. FOCARDI, R. HABEL, F. PIANTELLI, *Il Nuovo Cimento* 107 A, 163 (1994).
3. V. NASSISI, *Fus. Technol.* 33, 468 (1998)
4. V. NASSISI AND M.L. LONGO, *Fus. Technol.* 31, 247 (2000)
5. T. SUGII, T. ITO AND H. ISHIKAWA, *Appl. Phys. Lett.*, 45, 966 (1984)
6. V. VIOLANTE, *Fus. Technol.*, 35, 361 (1999)
7. F. FRISONE, *Proc. of VIII International Conference on Cold Fusion, ICCF-8* (2000).
8. G. STOPPINI, *Fus. technol.* 34, 81 (1998)

CHAPTER 5

RESEARCH IN UNIVERSITIES

(Institutes, Departments and INFM Sections)

(by **SERGIO MARTELLUCCI***)*

5.1. Introduction

This chapter reports some of the many contributions to the Italian research in the field of Cold Fusion carried out at Institutes, Departments and INFM Sections hosted by the Italian Universities.

It is a source of pride for Italy remembering in this introductory notes that the first theory anticipating the existence of a trigger threshold for fusion reaction and the prevalent ^4He production is due to Tullio Bressani of Turin University, Emilio Del Giudice and Giuliano Preparata of Milan University (who unfortunately passed away just like F. De Marco, already mentioned in the introduction to the previous chapter). In 1989 these three brilliant Italian physicists published the first convincing theory of a possible nuclear process in condensed matter.

The research activities being carried out at the Energetics Department of “La Sapienza” University of Rome are not reported here as they have already been mentioned in the previous chapters. Anyway it is proper remembering here that the Italian Ministry for Economic Development has financed the two-year research project named “Produzione di Eccesso di Potenza in Metalli Deuterati” (Power Excess Production in Deuterated Metals), within which patents have been obtained on the use of laser stimulation techniques in cathode metallurgy developed at ENEA Frascati.

5.2. The Dialogue Between Theory of Coherence and Cold Fusion

EMILIO DEL GIUDICE

INFN - Milan

In March 1989 the information media reported, all over the world, the announcement by Martin Fleischmann and Stanley Pons that they have achieved Cold Fusion. Cold Fusion is the process where, at room temperature, nuclei of deuterium – heavy hydrogen isotope with a nucleus made of a proton and a neutron fuse producing energy equivalent to 24 MeV (million electron volts) XX , whenever they are placed in the Pd crystalline lattice and their concentration exceeds the threshold of one deuterium nucleus for each palladium nucleus.

At that time I was working in Milan with Giuliano Preparata on the theory of Coherence. Coherence is the property by which a set of oscillators (both material particles and field modes) move in unison at a well-defined phase, like a corps de ballet.

A quantum system is made up of fluctuating components each with its own phase; when these single phases correlate in a uniquely defined phase of the overall set we achieve coherence. Coherence is maintained by the gauge field which, in the case of atoms, is the potential of the electromagnetic field. Correlations are kept by a field travelling at the phase velocity , that can well exceed the speed of light, thus forming wide extended coherent regions (coherence domains). Within these areas, dynamics is synchronic, i.e., it is not supposed to propagate accidentally, as it happens among independent particles, not phase-correlated.

These considerations, already familiar at the time, allowed us not to be victims of that disease which Brian Josephson, Nobel Prize Laureate, recently defined as “pathological disbelief”, affecting those who think they know but actually they know nothing and do not know they know nothing.

As a matter of fact, the Cold Fusion theorists there faced by a great conceptual difficulty which was best described by the Nobel-Prize laureate, Anthony Leggett. In Cold Fusion, the process of nuclear fusion is controlled by the dynamics of the crystalline lattice containing the deuterium nuclei.

The conceptual difficulty rises from the fact that the typical times of the lattice dynamics, as given by the conventional solid state physics, that does not include the concept of coherence, are much longer than the typical times of a nuclear process. How, then, could lattice dynamics affect a nuclear process?

We bypassed such difficulty by considering the lattice as a coherence domain, characterized by a synchronic dynamics, just as shown by the Mössbauer effect we were right then studying, together with Tullio Bressani, who proposed the notion of “inverse Mössbauer effect” for Cold Fusion.

This role of synchronic dynamics of the coherence domain in Cold Fusion also implied that the energy emitted in each single fusion – as well as the recoil momentum of every nucleus decaying during the Mössbauer effect – belongs to the whole coherence domain, and its emission does not cause the break-up of the nucleus produced by fusion. Therefore, in the case of Fleischmann and Pons, such nucleus remains helium-4.

This prediction was immediately clear to us and was reported in the first article published on *Il Nuovo Cimento* in May 1989 and in the Salt Lake City Conference report by Giuliano Preparata in Spring 1990.

The coherence theory was to give another important contribution. In deuterium coherence domains, the phase is changed by the potential of the electromagnetic field (the well-known Böhm-Aharonov effect). As the phase is also related to the chemical potential of domains, it is possible to change the chemical potential (in particular, reducing it) through an external electromagnetic potential. Giuliano Preparata conceived this important result in 1993, when he learned from Martin Fleischmann about Alfred Cöhn's important 1929-1933 experiments on the propagation of hydrogen ions in metals. The electrical potential was chosen as an agent; the application of a negative potential to a unidimensional cathode (e.g., a wire) would determine such a reduction in the deuterium chemical potential as to cause a massive inflow of deuterium nuclei in the cathode thus rising the deuterium/palladium stoichiometric ratio up to the values triggering the nuclear process. The potential applied to the wire obviously produced also an electric current. To minimize such current and its consequent negative impact on coherence, it was necessary to reduce the cross section of the wire as much as possible.

Giuliano wittily called this effect “Cöhn-Aharonov” (in assonance with Böhm-Aharonov), but after his death on Aprile 24, 2000, we renamed it “Preparata effect”.

The prospect of a rapid and effective loading of palladium cathodes up to the values critical for cold fusion opened up a new prospect to the developments of Cold Fusion.

In order to examine closely this perspective, the possibility of a cooperation with industry was explored. Preparata established contacts with some great industries, in particular Fiat and Edison, and carried out preliminary research activities with their collaboration. Especially in collaboration with Edison, a calorimetric method was set up, based on the initial suggestion by Fleischmann to determine the energy released during Cold Fusion.

This method was based on the isoperibolic calorimetry and allowed to evaluate the released energy on the basis of the often repeated determination of the coefficient correlating the inflow of small known heat amounts in the system and the consequent temperature variation. In that way, it was possible to overcome the problem related to calorimetry represented by the fact that the energy produced by Cold Fusion was released in radiative form in a very short time so that only a small fraction thermalized near the source and therefore was detectable by a normal calorimeter. Actually the determinations based on the isoperibolic method produced values as much as about ten times higher than the determinations made by way of the normal calorimetry. This discrepancy gave rise to a new epidemics of “pathological disbelief”.

The problem was then vindicated by the experiments carried out at ENEA Frascati, where the measurement of the number of the produced ^4He nuclei carried out by a mass spectrometer, allowed to trace back directly to the produced energy. The heat events found were as much as ten times higher than the ones found by the calorimeter, exactly the same ratio found by way of isoperibolic calorimetry, whose exactness was thus claimed.

In 1996 a new research period began. A research company, LEDA (Advanced Electrodynamics Laboratory), was set up in Milan. LEDA partners were Giuliano Preparata, an entrepreneur from Trieste, Mr. Zacchigna, Pirelli Cavi S.p.A. and a financial institution presided by Massimo Moratti.

For about two years, this company carried out an intense research activity. By using the Preparata effect for cathode loading and the isoperibolic calorimetry as the method to measure the produced energy, some hundreds of experiments were carried out during which various layouts were tried. The results were very encouraging on condition that the prejudices against isoperibolic calorimetry, still in force at the time, were overcome. The achieved densities of produced energy were of the order of some kilowatts per cubic centimeter of palladium cathode with a ratio of produced energy/used energy of the order of $5 \div 10$.

LEDA activity received also Martin Fleischmann's contribution, besides that by the usual collaborators of Giuliano Preparata.

LEDA activity ended at the end of 1997 for financial reasons, but paved the way to a new phase where research moved to ENEA Frascati. LEDA results lead Massimo Scalia, deputy of the Green party at that time, to involve the then Director General of ENEA, Renato Strada, in order to carry on this research line at Frascati's laboratory, where research on Cold Fusion had already achieved important results thanks to the work of Francesco Scaramuzzi, Antonella De Ninno, Antonio Frattolillo, Vittorio Violante and others.

These efforts lead to the launching of a new research program, centred on Frascati's laboratory, that received a new momentum in 1999, when Carlo Rubbia was appointed President of ENEA.

Giuliano Preparata moved to Frascati, where he remained until his premature death on April 24, 2000. The group he directed included, besides myself, Antonella De Ninno, Antonio Frattolillo and some young graduates and students. After his death this group carried on research which ended in 2002 with the achievement of the expected objective, i.e., the experimental demonstration that:

1. the application of a negative electric potential to a unidimensional palladium cathode causes an increase of loading up to values of the stoichiometric ratio higher than 1, in line with the experiments carried out at LEDA;
2. as the critical value of the stoichiometric ratio is exceeded, a heat quantity exceeding the energy introduced in the electrolytic cell, is detected by a calorimeter based on Peltier effect; and,

Concomitantly with the appearance of this anomalous heat, equivalent to a power of some tens of watts per cubic centimeter, a number of ^4He atoms widely exceeding the environmental background appears in the mass spectrometer. This ^4He anomalous quantity is the “ash” of the nuclear reaction. The ash quantity allows to estimate the total energy produced, which turned out to be of about 300 watts per cubic centimeter of palladium, i.e., lower than the values found at LEDA.

The existence of Cold Fusion and its main features were, therefore, definitely proven. These results were reported in the Cold Fusion Conferences held in Beijing (2002) and in Boston (2003), and published in the related Proceedings.

Yet, the attempt to publish these results on scientific journals was toughly contrasted by the resistance of publishers, who refused to publish them on various grounds ranging from the lack of room to the unavailability of competent referees, going as far as to requesting that the experiments be repeated several times. Actually, even a single anomalous event needs to be explained to a rational mind!

These deeds can be a good material to be studied to understand the internal dynamics of scientific society and have been the object of an interesting documentary produced in 2006 by the Italian Television Network RAI News 24 and entitled “Report 41”. Report 41 is the title of the ENEA internal technical report describing our results.

Only recently our results have been collected in an official peer-reviewed publication, edited by the American Chemical Society, which appeared on August 2008. The bibliography of this publication, referred to as Ref. 4 in the bibliography of the present article, lists the references to the scientific articles relating to the research activities I have mentioned so far.

The conclusion of this phase of research in 2002 did not produce any further development also because of the lack of financial support by both ENEA and others. On the other hand, the coherence theory has found application in other fields, first of all biology which has drawn the attention of some of us.

Going back to Cold Fusion, it can be noticed that if the use of unidimensional cathodes on the one hand allowed for the rapid achievement of such loading levels as to trigger the nuclear phenomenon, on the other hand it shows strong difficulties as the cathode, being very thin and, therefore, fragile, breaks up easily as strong heat events occur due to nuclear fusion.

The cathode breaking-up brings the phenomenon to an end. During the experiments the average life of a cathode did not exceed some days, so the prospect of a practical use needs the elaboration of a type of cathode much stronger yet still susceptible to an easy loading by using the resources supplied by the coherence theory. There are many clues in this direction, but this is a matter of the future.

References

Note: The bibliographic references to the articles produced during the research activities described in this text may be found in the references of the four texts quoted in the following bibliography.

1. G. PREPARATA, *QED Coherence in Matter* – World Scientific, 1995
2. G. PREPARATA, *Dai quark ai cristalli*, Bollati-Boringhieri, 2002 (in Italian)
3. R. GERMANO, *Fusione Fredda*, Bibliopolis, 2002 (in Italian). This text contains a complete bibliography updated as of 1998 (second edition)
4. A. DE NINNO, E. DEL GIUDICE, A. FRATTOLILLO, *Evidence of Coherent Nuclear Reactions in Condensed Matter*, in the volume “Low Energy Nuclear Reactions Sourcebook”, American Chemical Society Symposium Series (ed. J. Marwan and S. Krivit), Oxford University Press (August 2008) and the publications quoted in its bibliography

5.3. Anomalous effect between 200 and 400 °C on Ni-H Systems. Neither chemical nor electrochemical phenomenon

SERGIO FOCARDI, FRANCESCO PIANTELLI

I.M.O. Bologna and Siena,

Introduction

This report concerns the experimental results obtained by two groups of researchers and collaborators, belonging to inter-university center I.M.O. from Bologna (Focardi, Campari) and Siena (Piantelli, Gabbani, Montalbano, Veronesi); all of them have always participated to the researches in the field of LENR.

All the references cited in this report are listed in a chronological order; they are divided into four different sets: articles published on journals with referee (R), presentations in academies and national or international conferences (A), presentation at national congresses of the Italian Physics Society SIF (S), degree theses (T).

The research in the field of nickel – hydrogen systems started from an experimental observation by F. Piantelli at the end of 1989 concerning a strange thermal effect at low temperature in a sample of nickel with hydrogen. Piantelli spoke of this effect to his friends S. Focardi and R. Habel during the SIF congress in Trento (October 1990). They decided to experimentally verify the observed phenomenon, which had been obtained in a context completely different from the electrochemical one of Fleischmann, Hawkins and Pons (J. Electroanal. Chem. 261, 301 (1989)) and with completely different working hypothesis which cannot be taken back to be CF or electroweak interactions (EWI); at present this hypothesis is going to be supported by some experimental results while concerning the CF there are not sufficient specific experimental proofs as well as concerning EWI there are not the required energy amounts besides some violations conservation laws.

The experiments were preceded by many experimental observations performed in Siena by Piantelli alone; they started in Bologna, Cagliari and Siena and they were obviously performed with a high degree of discretion because of the importance of the phenomenon and its possible use for energy production.

Later some experiments were performed also in Colleferro and in Pavia. In any case the largest part of the experimental activity took always place in Siena.

The initial phase was very slow because of the chronic lack of funding. It was possible to perform the experiments thanks to the kind help of colleagues and friends from the University of Siena and Bologna, from INFN, ENEA, CNR of Pisa, CISE, Navy Academy and the Municipality of Bologna. In this way, by means of loans and direct participations, the instrumentation necessary for the first experimental investigations became available.

The first phase of the common work ended at the end of 1993 with the publication of the first obtained results (R1). It was shown that nickel samples in a hydrogen atmosphere were able to produce additional power up to 50 W, after absorbing a given amount of gas, at temperatures in the range 150-400 °C, heated with power among 40 and 120 W. The energy production started after perturbing the system with power or pressure changes. In one case, before stopping the process, the system was kept for 24 days in stationary conditions with a power of 44 W corresponding to a total energy of 90 MJ produced. This first important result had been preceded by many experimental observations (A1). As a consequence of these first results it was possible to involve new important partners, such as FIAT AVIO S.p.A., the consortia T.E.S.C.A. (Bulla, Bergomi e Foglia, Italkero, Ecosystem) and PROVITA s.r.l..

To the first experimental observations (A1) performed before the end of 1994 many other systematic measurements were added; some of them were performed in Siena (8), others in Bologna (2), Colleferro (1) and Pavia (1). The total number of performed measurements from which all the experimental observations of the phenomenon have been deduced is equal to 21.

Power measurements are described in a detailed way in R2; they have been obtained, starting from 1994, by means of the Newton law, to find the thermal power emitted by the surface by means of the measured temperature difference ($T_c - T_a$), where T_c is the temperature in a given zone of the cell surface and T_a is the environment temperature inside the lab. This power can be compared to the electrical power supplied to the system, thanks to an initial calibration performed before the system starts the energy production.

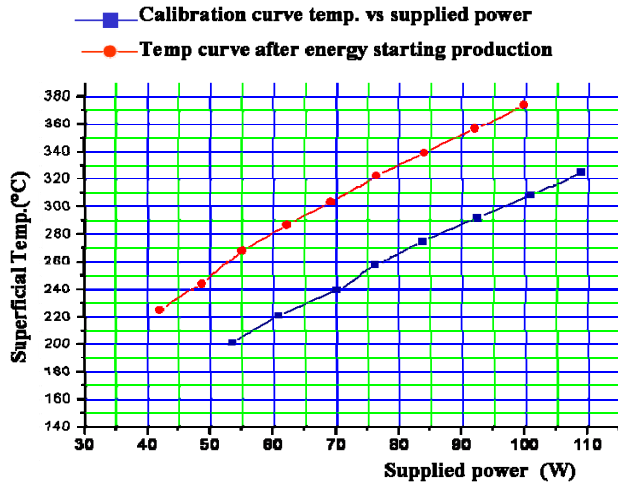

Fig. 1.a)
Temperatures are referred to the lab temperature ($T_c - T_a$)

Typical cell activation

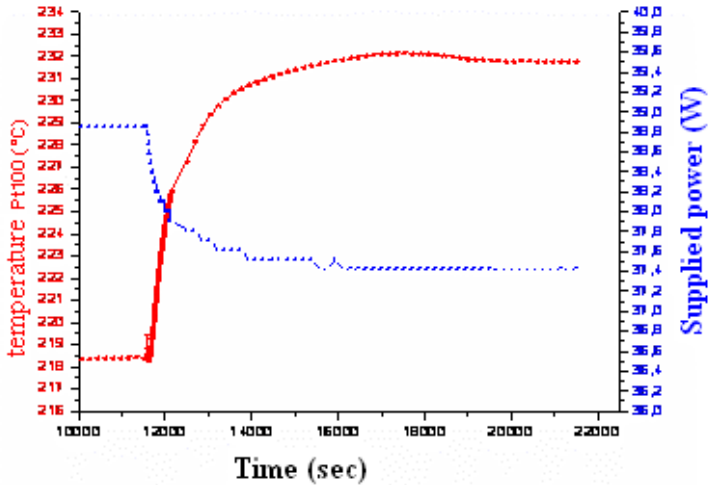

Fig 1b)
Typical result of the experiments performed at Physics Department of Siena

Fig. 1 - Monitoring of the energy production

- a) **calibration curve** as a function of the supplied power (blue); temperature curve after energy production starting (red)
- b) **energy production** process: temperature (red) and supplied power (blue) as a function of time. When the temperature increases, because of the energy production phenomenon, there is a decrease of the provided power due to the growth of Pt heater resistance supplied by constant continuous voltage.

Moreover, since the system is continuously monitored, it is possible to evaluate the fluctuations and all the variations in the system behavior. In order to evaluate the produced energy we used the resistance variation technique both of a Pt-100 thermometer and of the Pt heater as a function of the temperature with a supply system in direct current with rigorously constant voltage; the actual produced power is evaluated by means of the decrease of the current due to the increase of the temperature caused by the beginning of the energy production process.

Hydrogen absorption in nickel

The observed phenomena of thermal energy production by the Ni-H system starts after the absorption of a certain amount of hydrogen by the nickel. The amount of absorbed hydrogen is not constant and it possibly depends on the metallic sample treatment. In some situations we did not observe any absorption (nor energy production); in others only small quantities of hydrogen were absorbed. Finally, in other situations, a very large amount of H was absorbed and in very short times (A2, A7).

In order to be sure that the hydrogen pressure decrease inside the cell was not due to leaks, we always worked at H pressure smaller than the atmospheric one (R1); when the pressure decreased because of the absorption process we reintroduced other hydrogen in order to recover the starting value. In the fastest observed case (A3, T4) the whole loading process lasted for 80 hours only.

Generally the absorption process lasted for several days. Moreover we have observed the existence of some temperature values corresponding to extremely high gas absorption rates from the nickel (A3); this phenomenon had never been reported in the previous literature.

From the study of the H loading phenomenon we conclude that this first process is essential in order to observe the energy production. In other words, if the metal does not absorb the hydrogen, there is not any anomalous effect.

The gas absorption was put into evidence not only by means of the pressure decrease but also by the experimental diagram pressure-power: in some regions it is in complete disagreement with the Gay-Lussac law connecting pressure and temperature; there is also a clear indication of hysteresis (A3).

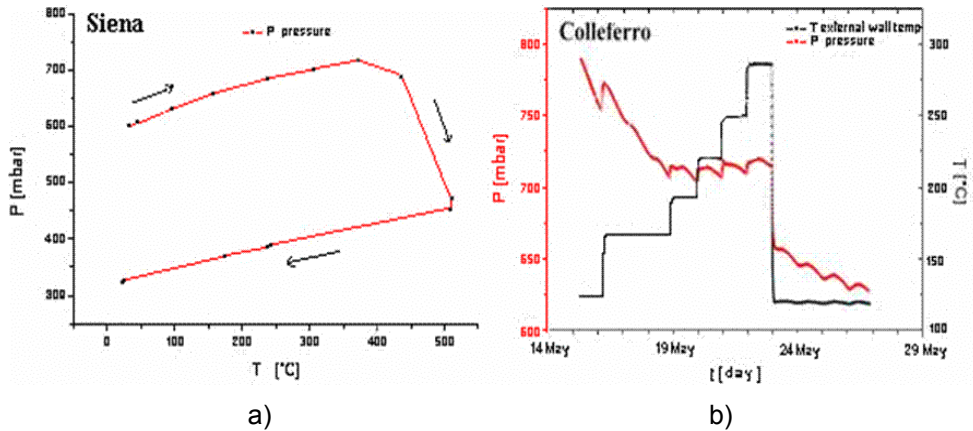

Fig.2

a) Hydrogen absorption as a function of the temperature in a heating and cooling cycle

b) Hydrogen absorption as a function of the time (red) in a test with step supply

Energy production from the Ni-H system

The first observations of the energy production by the system were obtained from the temperature changes of the Pt heater located inside the experimental cells (the description of the experimental setup can be found in R1). Later on, because of some criticisms which attributed the observed effect to the modifications of the Pt electrical resistance due to the hydrogen absorption by the Pt itself, we decided to measure the effects from outside the cells (R2).

In summary, as already pointed out, the adopted technique uses the Newton law: we measured the difference ($T_c - T_a$) between the temperature T_c in a region of the container external wall and the temperature T_a of a thermometer, located far from the container, which measures the lab environment temperature, as a function of the supply electric power. In this way, at the beginning of the experiment (when no anomalous phenomenon is present), we obtained the experimental calibration curve; the produced energy is evaluated from the comparison among the curves obtained when the system is producing energy and the calibration curve.

The best results were obtained by means of two cells which produced about 900 MJ and 600 MJ working for 278 days and 319 days respectively before being stopped. At the end of the experiment the first one gave an energy production with a power equal to about 70 W to be compared with the supply power equal to 29 W (total 99W).

Observation of events of nuclear origin

During the experiments, which altogether lasted for about 15 years, many phenomena witnessing nuclear reactions inside Ni samples in H atmosphere were observed. While it was producing energy, the cell which produced 900 MJ emitted neutrons for some days; this emission was observed with two different techniques, i.e. by means of ^3He neutron counters and the Au activation. The last method (R3) allowed to evaluate the flux of emitted neutrons: it was $10 \text{ neutrons/cm}^2\text{s}$, which is equal to 1000 times the neutron flux due to cosmic radiation.

In many cases and with different cells, electromagnetic radiation emission (with energy of the order of 100 keV) was observed; by comparing of the spectrum measured by means of NaI(Tl) and Ge counters, located close to the cell, with that due to the environment background in the lab (A3). The Ni sample, once extracted from the cell which produced 900 MJ, kept for many hours in contact with a photographic emulsion, left a radiographic impression (T4). The same sample, put inside a Wilson cloud chamber, allowed photography of the tracks due to heavy particles (A5).

Other events, whose existence can only be due to nuclear reactions, were observed at the end of the experiments by means of the SEM-EDAX technique for the analysis of the used sample surfaces. Taking into account the fact that the used system is the gas-metal couple, constituted by hydrogen and nickel, if we find on the surfaces other elements, not present in any component of the cell, they must come from nuclear reactions. As reported in A5, on the whole we observed in remarkable quantity Cu and Zn (with atomic number greater than Ni), F, Na, Mg, Al, Si, P, S, Cl, K, Ca, Mn, Cr, Fe (Fig. 3).

The fact that nuclear reactions took place in experiments in which there was thermal energy production is witnessed also by an accurate inspection of the Ni sample surface; in fact locally, in some regions, there are surface deformations and considerable ruptures which cannot be justified on the basis of the temperature (around $400 \text{ }^\circ\text{C}$ at maximum) produced by the heater and measured and on the basis of the embrittlement because very low amount of the absorbed H ($X < 0.08$).

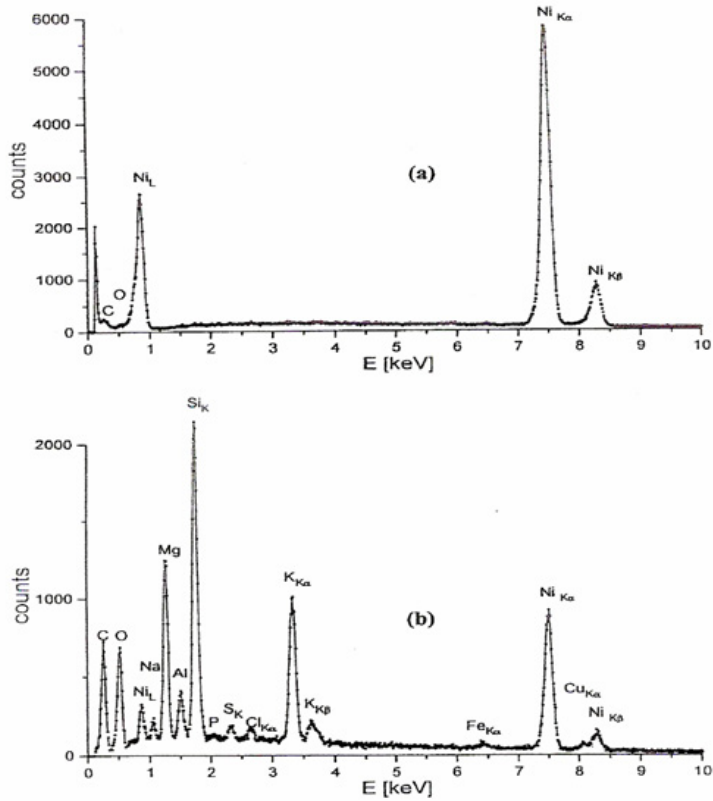

Fig. 3 - SEM-EDAX analysis of the surfaces

- a) spectrum detected on the rod surface in a region where there was not energy production
- b) spectrum detected on the rod surface in a region where there was energy production as measured by means of the temperature on the external cell surface

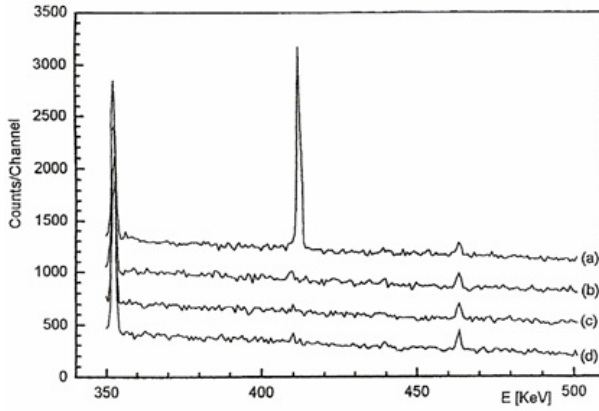

Fig. 4 a)

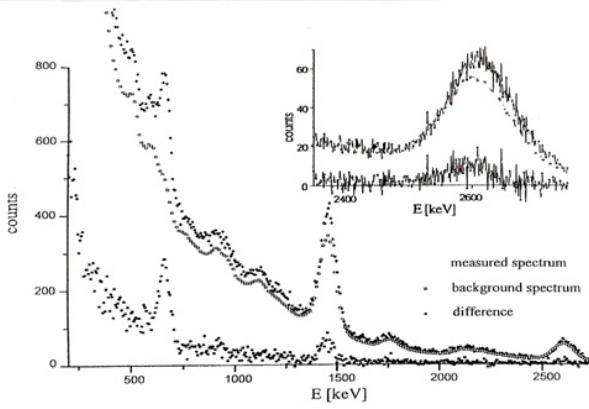

Fig. 4 b)

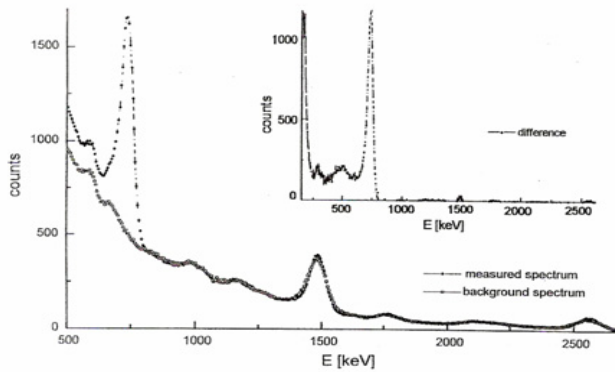

Fig. 4 c)



Fig. 4 d)

Fig. 4

- a) 411 keV peak of the Au activated by neutrons
- b) photograph of heavy particles emitted by the Ni rod after the extraction from the cell
- c) a photon emission spectrum measured by means of NaI(Tl) counter
- d) a photon emission spectrum measured by means of Ge counter

Bibliography

Reviews

- (R1) S. FOCARDI, R. HABEL AND F. PIANTELLI - *Anomalous Heat Production in Ni-H Systems*. Il Nuovo Cimento 1994, Vol 107A, pp 163-167
- (R2) S. FOCARDI, V. GABBANI, V. MONTALBANO, F. PIANTELLI AND S. VERONESI - *Large excess heat production in Ni-H Systems*. Il Nuovo Cimento 1998, Vol 111A, pp 1233-1242.
- (R3) BATTAGLIA, L. DADDI, S. FOCARDI, V. GABBANI, V. MONTALBANO, F. PIANTELLI, P.G. SONA AND S. VERONESI - *Neutron emission in Ni-H Systems*. Il Nuovo Cimento 1999, Vol 112A, pp 921-931.

Proceedings

- (A1) F. PIANTELLI, Atti Accad. Fisiocritici, Serie XV, Tomo XXII, pag 89 (1993).
- (A2) S. FOCARDI, V. GABBANI, V. MONTALBANO, F. PIANTELLI AND S. VERONESI, Atti Accad. Fisiocritici, Serie XV, Tomo XV, (1996) pp 109-115.

- (A3) S. FOCARDI, V. GABBANI, V. MONTALBANO, F. PIANTELLI AND S. VERONESI - *On the Ni-H System*. Conference Proceedings vol 64, "Asti Workshop on Anomalies in Hydrogen/Deuterium loaded metals", W.J.M.F. Collis (Ed.), SIF Bologna 1999 pp 35-47.
- (A4) S. FOCARDI, V. GABBANI, V. MONTALBANO, F. PIANTELLI AND S. VERONESI - *Gamma emission from Ni-H Systems at 420-750 °K*
Atti Accad. Fisiocritici, Serie XV, Tomo XVIII, (1999) pages 109-118
- (A5) E. G. CAMPARI, S. FOCARDI, V. GABBANI, V. MONTALBANO, F. PIANTELLI, E. PORCU, E. TOSTI AND S. VERONESI - *Ni-H Systems*. Proceedings of the 8th International Conference on Cold Fusion, Lerici (La Spezia), Italy 21-26 May 2000, pp 69-74.
- (A6) E. G. CAMPARI, S. FOCARDI, V. GABBANI, V. MONTALBANO, F. PIANTELLI, S. VERONESI - *Thermal Surface effects in Hydrogen and metals*
Proceedings Workshop TESMI, A. Lorusso e V. Nassisi eds, Lecce 2002, 35 (2002).
- (A7) E. G. CAMPARI, S. FOCARDI, V. GABBANI, V. MONTALBANO, F. PIANTELLI, S. VERONESI - *Overview of H-Ni Systems: old experiments and new setup*. 5th Asti Workshop on Anomalies in Hydrogen\Deuterium Loaded Metals, Asti 19-21 March 2004, to appear on Condensed Matter Nuclear Physics
- (A8) S. FOCARDI, V. GABBANI, V. MONTALBANO, F. PIANTELLI, S. VERONESI - Evidence of electromagnetic radiation from Ni-H Systems, The 11th International Conference on Condensed Matter Nuclear Science, Marsiglia 31 October-5 November 2004.
- (A9) E. G. CAMPARI, S. FOCARDI, V. GABBANI, V. MONTALBANO, F. PIANTELLI, S. VERONESI - Surface Analysis of hydrogen loaded nickel ALLOYS, The 11th International Conference on Condensed Matter Nuclear Science, Marsiglia 31 October-5 November 2004.
- (A10) E. G. CAMPARI, G. FASANO, S. FOCARDI, S. LORUSSO, V. GABBANI, V. MONTALBANO, F. PIANTELLI, C. STANGHINI, S. VERONESI - Photon and particle emission, heat production and surface transformation in Ni-H system, The 11th International Conference on Condensed Matter Nuclear Science, October-5 November 2004.
- (A11) E. G. CAMPARI, S. FOCARDI, V. GABBANI, V. MONTALBANO, F. PIANTELLI, S. VERONESI - *Overview of H-Ni Systems: evidence di H adsorption, Heat production, Photon and particle emission and surface transmutations*. - The 6 International Workshop on Anomalies in Hydrogen/Deuterium loaded Metals, Siena 13-16 May 2005

(A12) E. G. CAMPARI, S. FOCARDI, V. GABBANI, V. MONTALBANO, F. PIANTELLI, S. VERONESI – *New experiments on Ni-H Systems* – Atti Accademia dei Fisiocritici (2005) (in stampa).

(A13) E. G. CAMPARI, S. FOCARDI, V. GABBANI, V. MONTALBANO, F. PIANTELLI, S. VERONESI - *Energy production and nuclear reaction in Ni-H Systems* - The 7 International Workshop on Anomalies in Hydrogen/Deuterium loaded Metals, Asti 23-27 September 2006

Presentations at national and international conferences

(S1) S. FOCARDI, R. HABEL AND F. PIANTELLI - *Evidenza di reazioni nucleari in sistemi nichel-idrogeno a 400 gradi Celsius*, 81^o Congresso Nazionale della Società Italiana di fisica, Perugia 2-7 ottobre 1995.

(S2) S. FOCARDI, V. GABBANI, R. HABEL, V. MONTALBANO, F. PIANTELLI, G. SOLVETTI, A. TOMBARI, S. VERONESI - *Evidence of Heat Production and Nuclear reactions in Hydrogen Loaded Nickel Rods in Siena Experiments*. – Convegno “Stato della fusione fredda in Italia” – Siena (1995)

(S3) S. FOCARDI, V. GABBANI, V. MONTALBANO, F. PIANTELLI, C. STANGHINI, S. VERONESI - *New Experimental Evidence of Nuclear Reactions in Ni-H Systems* – LXXXI Congresso nazionale S.I.F. – Verona (1996)

(S4) E. CAMPARI, S. FOCARDI, V. GABBANI, R. HABEL, V. MONTALBANO, F. PIANTELLI, S. VERONESI, E I. USAI - *Studio di sistemi Ni-H nella regione 600-800 K*, 83^o Congresso Nazionale della Società Italiana di fisica, Como 27-31 ottobre 1997.

(S5) E. CAMPARI, S. FOCARDI, V. GABBANI, V. MONTALBANO, F. PIANTELLI E S. VERONESI - *Emissione di raggi gamma da sistemi Ni-H*, 84^o Congresso Nazionale della Società Italiana di fisica, Salerno 28 settembre-2 ottobre 1998.

(S6) E. CAMPARI, S. FOCARDI, V. GABBANI, V. MONTALBANO, F. PIANTELLI E S. VERONESI - *Comportamento dei sistemi Ni-H*, 85^o Congresso Nazionale della Società Italiana di fisica, Pavia 20-24 settembre 1999.

(S7) E. CAMPARI, S. FOCARDI, V. GABBANI, V. MONTALBANO, F. PIANTELLI, E. SALI, C. STANGHINI E S. VERONESI - *Alcuni aspetti delle interazioni Ni-H*, 86^o Congresso Nazionale della Società Italiana di fisica, Palermo 6-11 ottobre 2000.

(S8) E. CAMPARI, G. FASANO, S. FOCARDI, V. GABBANI, V. MONTALBANO, F. PIANTELLI, C. STANGHINI E S. VERONESI - *Interazioni H-superfici metalliche: effetto FASEC, analisi comparata dei risultati sperimentali*, 90^o Congresso Nazionale della Società Italiana di fisica, Brescia 20-25 settembre 2004.

(S9) S. FOCARDI E F. PIANTELLI – *Produzione di energia e reazioni nucleari in sistemi Ni-H a 400 °C*, Conferenza nazionale sulla politica energetica in Italia, Università di Bologna, 18-19 aprile 2005.

Degree theses

(T1) ANTONELLA DI FABRIZIO - *Studio degli effetti termici in sistemi nichel-idrogeno*, Università di Bologna, Anno Accademico 1993-1994, sessione invernale.

(T2) LARA STUPAZZONI - *Misure del flusso di neutroni emessi in processi di fusione fredda*, Università di Bologna, Anno Accademico 1994-1995, sessione autunnale.

(T3) RAFFAELE MOLTI - *Misure di radioattività ambientale*, Università di Bologna, Anno Accademico 1994-1995, terza sessione.

(T4) ALESSANDRO VENTURA - *Un apparato sperimentale per lo studio di sistemi Ni-H*. Università di Bologna, Anno Accademico 1995-1996, sessione estiva.

(T5) ANNA ELISABETTA ZIRI - *Spettro della radiazione gamma con rivelatori al germanio e allo ioduro di sodio*, Università di Bologna, Anno Accademico 1995-1996, sessione autunnale.

(T6) BARBARA MIRRI - *Studio dei sistemi nichel-idrogeno*, Università di Bologna, Anno Accademico 1995-1996, sessione invernale.

(T7) ELENA FIUMANA - *Caratteristiche dei sistemi Ni-H nella regione 300-500 °C*, Università di Bologna, Anno Accademico 1995-1996, sessione invernale.

(T8) GIUSEPPE PETTINATO - *Rivelazione di neutroni ($E < 10$ MeV) con un contatore a scintillazione NaI(Tl)*, Università di Bologna, Anno Accademico 1995-1996, sessione invernale.

(T9) ANNALISA BERNARDINI - *Studio di processi nucleari in sistemi Ni-H*, Università di Bologna, Anno Accademico 1996-1997, seconda sessione.

(T10) BORIS VICINI - *Studio dei fenomeni nei sistemi Ni-H*, Università di Bologna, Anno Accademico 1996-1997, terza sessione.

(T11) PAOLA ZUCCHETTI - *Evidenze di reazioni nucleari in sistemi nichel-idrogeno*, Corso di perfezionamento in fisica, Università di Bologna, Anno Accademico 1996-1997.

(T12) ALESSANDRA FORNACIARI - *Sistemi metallo-idrogeno*, Università di Bologna, Anno Accademico 2000-2001, seconda sessione.

(T13) FEDERICA SALAMI - *Sistemi Pd-idrogeno*, Università di Bologna, Anno Accademico 2000-2001, terza sessione.

(T14) CLAUDIO CERRETO - *Processi nucleari nei sistemi TI/H a temperatura ambiente*, Università di Bologna, Anno Accademico 2004-2005, seconda sessione.

5.4. X-ray, Heat Excess and ^4He in the Pd/D System

**DANIELE GOZZI, RICCARDINA CAPUTO, FABIO CELLUCCI,
PIERLUIGI CIGNINI, GUIDO GIGLI**

“La Sapienza” Rome University – Chemistry Department

MASSIMO TOMELLINI

“Tor Vergata” Rome University – Chemistry Department

SALVATORE FRULLANI, FRANCO GARIBALDI

ISS Physics Laboratory

EVARISTO CISBANI, GUIDO MARIA URCIUOLI

ISS Physics Laboratory – INFN Health Unit

The title of the present contribution refers to the conclusive result (1) of over seven-year experimentation (2-14), carried out from 1989 to 1996 at the Chemistry Department of “La Sapienza” University of Rome. The research activity was focused on the electrochemical confinement of deuterium in palladium cathodes by operating simultaneously on several cells in toroidal configuration and monitoring, for each one of them:

- heat balance through flow calorimetry;
- tritium content in the electrolyte;
- tritium content in heavy water obtained by the catalyzed recombination of the electrolysis gases;
- electrochemical balance of D_2O (D_2O consumed volume vs. $\frac{v_{\text{D}_2\text{O}}}{2F} \int_0^t I dt$, where I and $v_{\text{D}_2\text{O}}$ are current intensity and D_2O molar volume respectively);
- ^4He content in the electrolysis gases;
- ^4He content in the cathode (ex-situ destructive method); and,
- Radiation emission high-sensitivity X-ray film.

The toroidal system was within a neutron detector (14) made up of 60 tubes with ^3He at 6 Atm. The efficiency of the whole system calibrated with ^{252}Cf source was 22%.

Since the beginning, the part of nuclear detection of experiments, except for ^4He measurement, was managed by researchers from ISS Physics Laboratory and from the INFN Health Unit, while the chemical, electrochemical, material science, calorimetric, etc. skills were found within the Chemistry Department of “La Sapienza” University of Rome.

The abstract and the final experimentation conclusions (1) are reported here below. The report was published in 1997 on the *Journal of Electroanalytical Chemistry* and published by the same review again in 1998, as *erratum* because of mistakes made by Elsevier Science in the text and in the composition of figures, reproduced here for the reader's convenience.

Abstract

The energy balance between heat excess and ^4He in the gas phase has been found to be reasonably satisfied even if the low levels of ^4He do not give the necessary confidence to state definitely that we are dealing with the fusion of deuterons to give ^4He .

In the melted cathode, the data of which are reported, no ^4He was found at the achieved sensitivity. X-ray film, positioned at 50 mm from the cell, roughly gave the image of the cathode through spots.

Extended considerations have been made to explain this evidence on the basis of the bundle nature of the cathode.

From these considerations, the energy of the radiation and the total energy associated to it have been estimated as 89 keV and 12 kJ, respectively. This value is $\approx 0.5\%$ of the energy measured by calorimetry in the same interval of time. The highest values of energy and excess power are 8.3 MJ and 10 W, respectively.

Conclusions

The results show an overall picture with its own internal consistency: ^4He is produced at the surface of the wires, but only the innermost wires in the bundle are active (see the discussion about the spots on X-ray film) and it is not found inside Pd.

On the other hand, the low levels of ^4He do not give the necessary confidence to state definitely that we are dealing with the fusion of deuterons to give ^4He .

No evidence of contamination by atmospheric ^4He was found by the detection of $^{20}\text{Ne}^{2+}$, and the energy balance seems quite well satisfied when ^4He , expected by the measured heat excess, is compared with ^4He found.

This result markedly overcomes the stagnant situation in the understanding of cold fusion phenomena, where heat excess measured was never counterbalanced by a proper number of nuclear particles, such as neutrons, as expected by the d, d fusion in plasma. Moreover, the exposure of the X-ray film is a clear-cut proof (very simple experimental device for which errors of measurement and/or of procedure, as well as artefacts cannot be invoked) that a nuclear phenomenon is at work.

We believe that the radiation detected has to be searched for among the stable isotopes of Pd or among its impurities having intense nuclear transitions close to the energy found. Work is in progress to check this route.

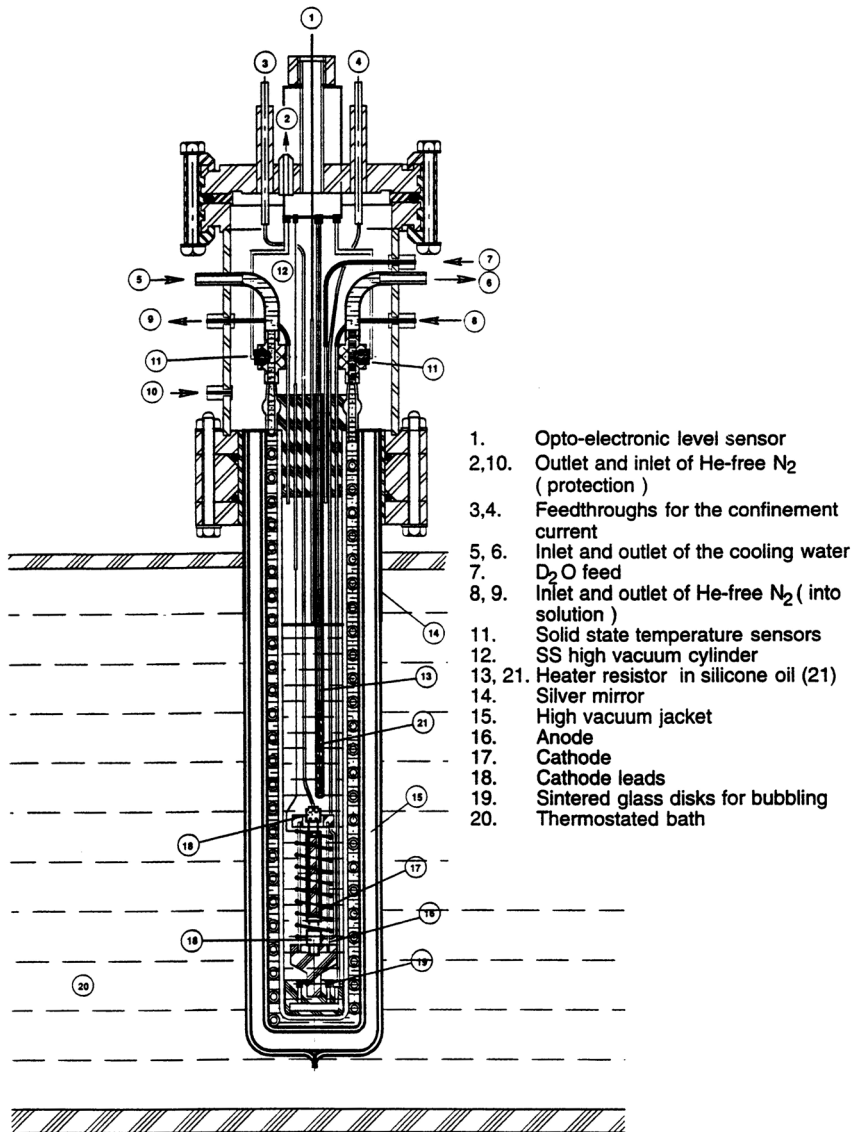

Fig. 1 - Cell for the electrochemical confinement of deuterium in palladium. The cell is a flow calorimeter allowing for electrolysis gas sampling through a current of N₂ free from ⁴He. It is designed to avoid air contamination. It is equipped with an internal heater for calorimetric calibration. D₂O is supplied by an opto-electronic level sensor

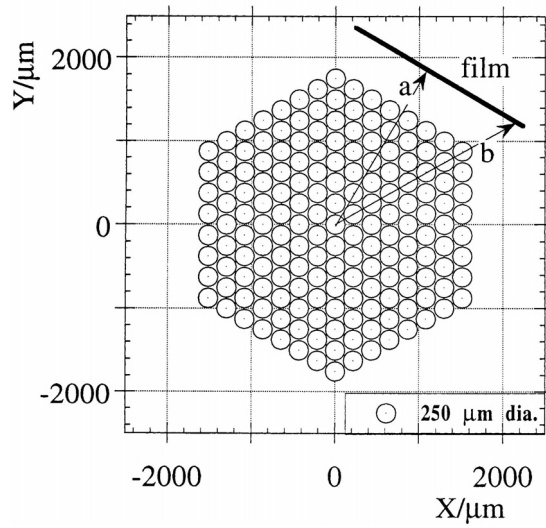

Fig. 2 – Representation of a cross-section of a bundle-type cathode as an ideal packing with 169 Pd wires of 250 μm diameter. The real cathodes used were made up of 150 wires

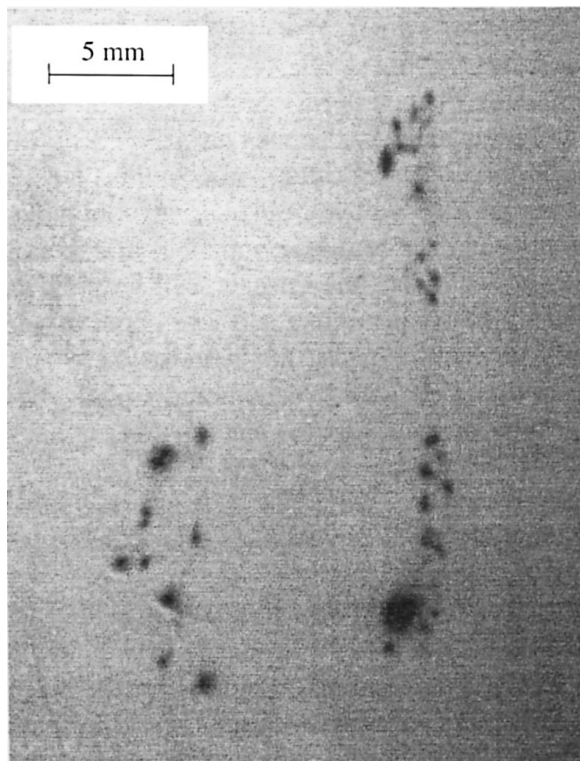

Fig. 3 – X-ray film as obtained after a one-week exposure in front of the cell #4

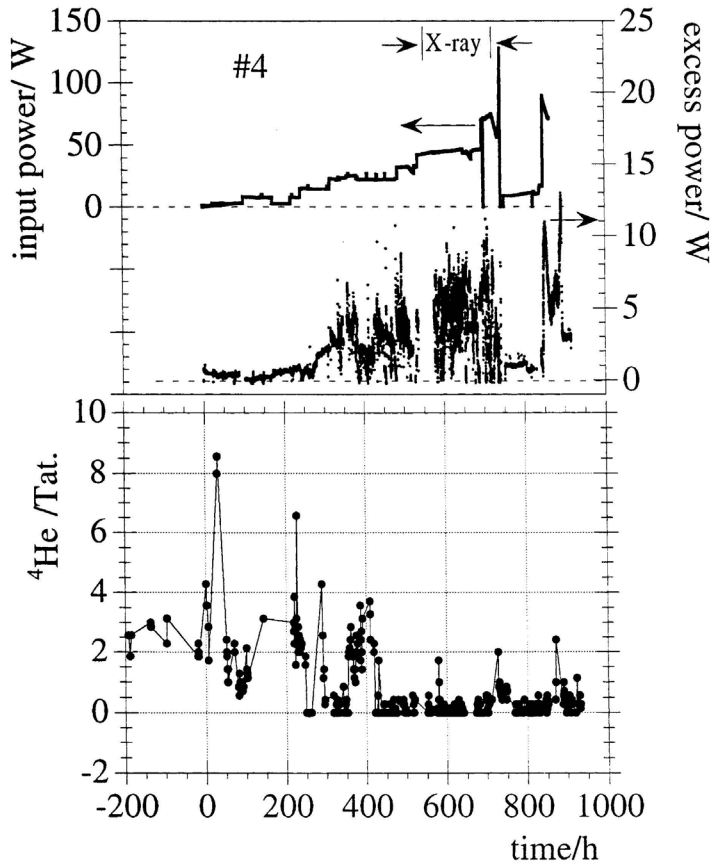

Fig. 4 - Cell #4. Cathode made up of a bundle of 250 μm -diameter Pd wires. Upper part: excess heat power (scale on the right) and total input power (scale on the left).

Lower part: ^4He content in teratoms measured in the electrolysis gases. Each point is the absolute quantity of ^4He in 150 cm^3 sampling volume

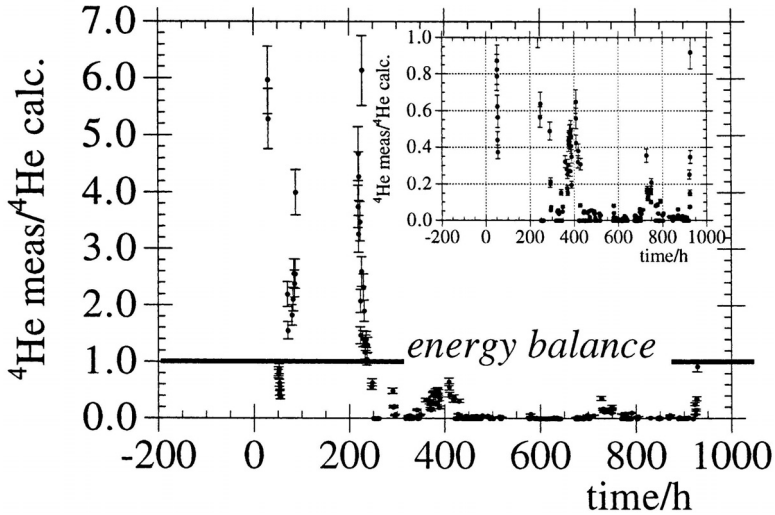

Fig. 5 - Ratio between measured and calculated ^4He (based on heat excess) as a function of time. The insert is a magnified view in the range from 0 to 1.

Values >1 involve that the measured ^4He is of atmospheric origin (in the present experiment the cause could be an incomplete washing of the whole line) or that the heat excess has been underestimated. It may be observed that from $t \geq 220$ h and until the end of the experiment the ratio value is steadily <1 , many points are >0 and close to energy balance

References

- 1) D. GOZZI, F. CELLUCCI, P.L. CIGNINI, G. GIGLI, M. TOMELLINI, E. CISBANI, S. FRULLANI,, G.M. URCIUOLI (1998) X-ray, *Heat Excess and ^4He in the Pd/D System*, J. Electroanal. Chem, -erratum- Vol. 452, pp. 251-271. [435(1-2) (1997) 113-136].
- 2) D. GOZZI, P.L. CIGNINI, L. PETRUCCI, M. TOMELLINI, G. DE MARIA, S. FRULLANI, F. GARIBALDI, F. GHIO, M. JODICE, *Characterization of one Single Outbreak of Possible "Cold Fusion" Events occurring in Palladium Heavy Water Electrolysis*, Conference Proceedings vol. 24 "Understanding Cold Fusion Phenomena", R.A. Ricci, E. Sindoni, F. De Marco (Eds.), Società Italiana di Fisica, Bologna 1989.
- 3) D. GOZZI, P.L. CIGNINI, L. PETRUCCI, M. TOMELLINI, G. DE MARIA, S. FRULLANI, F. GARIBALDI, F. GHIO, M. JODICE (1990) *Evidences for Associated Heat Generation and Nuclear Release in Palladium Heavy Water Electrolysis*, Nuovo Cimento Vol. 103A, pp. 143-154.

- 4) M. TOMELLINI, D. GOZZI (1990) *On the Possibility for Local Oversaturation of Deuterium in Pd*, J. Mat.Science Lett. Vol. 9, pp. 836-838.
- 5) D. GOZZI, P.L. CIGNINI, L. PETRUCCI, M. TOMELLINI, G. DE MARIA, S. FRULLANI, F. GARIBALDI, F. GHIO, M. JODICE, E. TABET (1990) *Nuclear and Thermal Effects during Electrolytic Reduction of Deuterium at Palladium Cathode*, J. Fusion Energy, Vol. 9, pp. 241-247.
- 6) D. GOZZI, P.L. CIGNINI, L. PETRUCCI, M. TOMELLINI, S. FRULLANI, F. GARIBALDI, F. GHIO, M. JODICE, G.M. URCIUOLI, AIP Conference Proceedings 228, *Anomalous Nuclear Effects in Deuterium/Solid Systems*, Provo, UT, October 22-24, 1990 (Eds. S. Jones, F. Scaramuzzi, D. Worledge), American Institute of Physics (New York) 1991, pp. 481-493
- 7) D. GOZZI, P.L. CIGNINI, M. TOMELLINI, S. FRULLANI, F. GARIBALDI, F. GHIO, M. JODICE, G. M. URCIUOLI, *Multicell Experiments for Searching Time-Related Events in Cold Fusion*, The Science of Cold Fusion, Conference Proceedings vol.33, Società Italiana di Fisica, Bologna (1991) pp. 21-47.
- 8) D. GOZZI, P.L. CIGNINI, M. TOMELLINI, S. FRULLANI, F. GARIBALDI, F. GHIO, M. JODICE, G. M. URCIUOLI (1992), *Neutron and Tritium Evidences in the Electrolytic Reduction of Deuterium on Palladium Electrodes*, J. Fusion Technology, Vol. 21, pp. 60-74.
- 9) D. GOZZI, P.L. CIGNINI, R. CAPUTO, M. TOMELLINI, G. BALDUCCI, G. GIGLI, E. CISBANI, S. FRULLANI, F. GARIBALDI, M. JODICE, G. M. URCIUOLI, *Experiments with Global Detection of Cold Fusion Byproducts*, in *Frontiers of Cold Fusion*, Edited by H. Ikegami, Frontiers Science Series no.4, Universal Academy Press Inc., Tokyo (1993) 155-164.
- 10) D. GOZZI, P.L. CIGNINI, R. CAPUTO, M. TOMELLINI, G. BALDUCCI, G. GIGLI, E. CISBANI, S. FRULLANI, F. GARIBALDI, M. JODICE, G. M. URCIUOLI, *Excess Heat And Nuclear Product Measurements in Cold Fusion Electrochemical Cells*, EPRI Report TR-104188-V1, Palo Alto, CA, vol. 1, p. 2-1/2-31 (1994).
- 11) D. GOZZI, P.L. CIGNINI, R. CAPUTO, M. TOMELLINI, G. BALDUCCI, G. GIGLI, E. CISBANI, S. FRULLANI, F. GARIBALDI, M. JODICE, G. M. URCIUOLI, *Helium-4 Quantitative Measurements in the Gas Phase of Cold Fusion Electrochemical Cells*, EPRI Report TR -104188-V1, Palo Alto, CA, vol. 1, p. 6-1/6-19 (1994).
- 12) D. GOZZI, P.L. CIGNINI, R. CAPUTO, M. TOMELLINI, G. BALDUCCI, G. GIGLI, E. CISBANI, S. FRULLANI, F. GARIBALDI, M. JODICE, G. M. URCIUOLI (1995), *Excess Heat And Nuclear Byproduct Measurements In Electrochemical Confinement of Deuterium in Palladium*, J. Electroanal. Chem., Vol. 380, pp. 91-107.

- 13) D. Gozzi, P.L. Cignini, R. Caputo, M. Tomellini, G. Balducci, G. Gigli, E. Cisbani, S. Frullani, F. Garibaldi, M. Jodice, G. M. Urciuoli (1995), *Helium-4 Quantitative Measurements in the Gas Phase of Pd-D₂O Electrolysis*, J. Electroanal. Chem., Vol. 380, pp. 109-116.
- 14) CISBANI, E.; URCIUOLI, G. M.; FRULLANI, S.; GARIBALDI, F.; GIULIANI, F.; GOZZI, D.; GRICIA, M.; IODICE, M.; LUCENTINI, M.; SANTAVENERE, F. (2001), *A neutron detector for cold fusion experiments*, Nucl. Instrum. Methods Phys. Res., Sect. A, Vol. 459, pp. 247-255
- 15) F. DI PASCASIO, D. GOZZI, B. PANELLA, C. TRIONFETTI (2005), *H₂ plasma for hydrogen loading in Pd*, Intermetallics, Vol. 11, 1345-1354
- 16) F. DI PASCASIO, D. GOZZI, B. PANELLA, C. TRIONFETTI (2005), *Pd/H system in H₂ plasmas*, J. Appl. Phys., Vol. 97, pp. 043304,1-11.
- 17) BALDI, F. DI PASCASIO, D. GOZZI (2006), *H₂ negative corona discharge on Pd/H system at low pressures*, Appl. Phys. Lett., Vol. 89, pp. 051918-20

5.5. Studying LERN at Livorno Naval Academy

LINO DADDI

Naval Academy – Physics Division - Livorno

From the early Nineties the Group headed by Prof. Lino Daddi kept up to date with research activities. Initiatives were taken, and various theoretical hypotheses were studied. The research activity focused on both the very cold fusion (with the participation of deuterium) and LENR reactions (of light hydrogen, essentially with the participation of electrons).

In March, 1993, the Naval Academy was the venue for the Conference named “*Meeting Cold Fusion*”. Among others, two of the main Italian protagonists took part to the meeting: Francesco Celani and Francesco Scaramuzzi. A report on cold reactions of light hydrogen was provided by Lino Daddi, who focused the discussion on the possibility that the cold p+d fusion could generate heat.

In September 1994 Daddi himself took part in an International Conference on *Cold Fusion and Nuclear Energy* held in Potenza, with an analogous report. On that very occasion Giuliano Preparata provided a general overview on the state of Cold Fusion.

During the same years an active collaboration took place in the field of energy amplification during the so-called “Siena Experiment”. The technique was conceived by Prof. Piantelli, of that same Athenaeum. Even Prof. Daddi took part in his first experiments. Heat production was stimulated by temperature variations in the Ni/H system, and occurred along with neutron and gamma-ray emission.

Later on, the description of the experiments carried out by don Carlo Borghi in Brasil (at CENUPFE nuclear headquarters of Recife University) was examined carefully in Livorno. During these experiments, many kind of neutron detectors were found to be radioactivated. Their activation was ascribed to the p+e reaction in a cold plasma of natural hydrogen.

In the meantime, Daddi realized that modes common to don Borghi’s and other LENR experiments could be explained thinking – as a work hypothesis – that the actual nuclear reactions were preceded by temporary, anomalous associations of a proton with an electron, hydrogen atoms strongly compact.

Those associations were called virtual neutron; yet in those cases where their duration seemed to be longer, Daddi proposed the general name of miniatoms. Hydrogen miniatom was already named “hydrex” by Dufour and “hydrino” by Mills.

Then, in the attempt of getting a wider theoretical support, the existence of “two-fold capture” chains was supposed, i.e., proton capture followed by orbital electron capture by the nucleus which, after capturing protons, remains in an excited state.

All of these hypotheses were exposed in the papers published by Daddi on Infinite Energy and on Fusion Technology (see References).

References

The Reports of the Livorno Conference were collected in a publication of Scientific Volume Series of the Naval Academy. The Potenza Conference reports were published on the review *21mo Secolo* no. 3 (July-September 1994).

The Siena Experiment was described in various articles on *Il Nuovo Cimento*. In particular, as for nuclear emissions, in “Neutron Emission in Ni-H systems” , Vol. 112 A, page 921

As for virtual neutrons and miniatoms :

- *On the Possible Role of Virtual Neutrons in Cold Fusion* – Infinite Energy- 35,58 (2001)
- Proton-Electron Reactions as Precursors of Anomalous Nuclear Events – Fus.Technol. 39,249 (2001)

As for two-fold capture:

- *Two-fold Capture of Miniatoms May Justify Many LENR Reactions* – Infinite Energy 47, 22 (2003)
- *Reazioni Neutroniche in Esperimenti LENR* – su Workshop TESMI Proc. - Lecce 2004 – page 1

CHAPTER 6

RESEARCH IN INDUSTRIAL LABORATORIES

(by **SERGIO MARTELLUCCI**)

6.1. Introduction

The Italian industry has been and is still interested in research on the Fleischmann-Pons electrochemical effect, also and mostly on its application as a potential alternative renewable energy source allowing to offset the world energy shortage and climate change by using fossil fuels.

In the previous chapters, the collaboration with many Italian and foreign industries has been stressed in the contributions of a number of authors from ENEA, INFN and various Universities.

In this chapter, contributions by Pirelli Labs SpA (www.pirelli.it), STMicroelectronics (www.st.it), and ORIM (www.orim.it) are reported, as an exemplification of this intriguing phenomenon of great industrial significance to a research field still far from being applied.

The web sites are indicated in order to make it easier to the reader to get more details about these Companies.

6.2. **Pirelli Group Activity in the Field of Cold Fusion**

FLAVIO FONTANA, LUCA GAMBERALE, DANIELE GARBELLI
Pirelli Labs SpA - Milan

Pirelli Group (first as Pirelli Cables & Systems and later as Pirelli Labs) did involve in cold fusion since the very beginning of this controversial research and held a little but significant presence in this basic research field.

After a first *scouting* phase, in 1995 Pirelli began collaborating with Giuliano Preparata's Group, aiming at analysing and checking its experimental results in this field.

At the same time, at our research laboratories the group made a detailed analysis of the theoretical model developed and proposed by Preparata, based on coherent quantum electrodynamics (c-QED)⁽¹⁾. Eventually the model was deemed substantially correct and worthy of further in-depth studies.

Although this preliminary work did not bring about immediate industrial developments, owing to the persistent lack of complete experimental reproducibility, Pirelli kept on feeling that c-QED was the right way to understand this elusive phenomenon and carried on a little research program on this line.

In the field of calorimetry on electrolytic cells, between 1997 and 1999 Pirelli repeated some of the results in electrolytic cells in "Preparata's way", highlighting some little (<10%) and erratic heat excess.

All measurements were carried out by means of a specially-developed flow calorimeter. Pirelli always avoided using indirect measurement methods, such as isoperibolic calorimetry, in order to achieve stronger and easy to interpret results.

At the same time, Pirelli carried on the theoretical work, broadening Preparata's model and checking its correctness.

During the following years, as the cold fusion phenomenon was not under such control as to assure a sufficient experimental reproducibility, Pirelli passed to an experimental analysis of hydrogen/deuterium loading in palladium, following the approach developed by Francesco Celani group at INFN.

The target achieved was to attain high loading factors, close to $[H]/[Pd] \sim 1^{(2)}$ with a good reproducibility.

An original measurement was that of palladium hydride ⁽³⁾ specific heat which evidenced – as it happens to other different physical quantities – a significant high loading variation occurring in correspondence to an hypothetical “gamma phase” ($[H]/[Pd] \sim 0.8$) of palladium loaded in hydrogen. This further underlines the hypothesis of a “nucleation” of a coherent phase.

After 2001, activities on cold fusion declined progressively because of the increasing difficulties in the field of Research and Development.

From 2005, Pirelli is involved in a three-year joint research with ENEA, in order to replicate the experimental results of Vittorio Violante's group. In particular, they intend to study, and possibly optimise the effect of a laser stimulus within an electrolytic cell.

References

- 1) GIULIANO PREPARATA – *QED coherence in matter*. World Scientific (1995).
- 2) D. AZZARONE, F. FONTANA, D. GARBELLI – *Hydrogen/deuterium loading in thin palladium wires*. Proceedings of the 8th International Conference on Cold Fusion (2000), pp. 199-204.
- 3) L. GAMBERALE, D. GARBELLI, G.PIANA – *Measurement of heat capacity of PdH_x*. Proceedings of the 9th International Conference on Cold Fusion (2002), pp. 105-108.

Note (added by Vittorio Violante): ENEA and Pirelli Labs signed a protocol agreement concerning different lines of research. Cold Fusion is one of those. Pirelli was concerned with replicating the experiments carried out in Frascati with materials set up at ENEA (already successfully used by Energetics and SRI). The agreement will be concluded by the end of 2008, but Pirelli activities concerning cold fusion research are supposed to be in “stand-by” since the end of 2007.

6.3. Cold Fusion Activities at STMicroelectronics

UBALDO MASTROMATTEO
STMicroelectronics - Milan

Introduction

This paragraph contains the most significant reports on the activity carried out at ST from 1994 until today, which keeps on being low-profile as long as the phenomenology proves to be applicable at the industrial level.

As regards the historical evolution of laboratory studies and activities, the main events can be synthesized as follows:

1994 – The hydrogen content in some dielectric films used in the microchip production process, causing problems of reliability in some integrated components, seems to be interesting for building a miniaturized cell based on a solid – and not liquid – electrolyte for the activation of phenomena ascribable to Cold Fusion.

1995 - At ST , a facility to check the effect of hydrogen absorption in the metal matrix on very thin Nickel layers is designed.

1996 – Experiments begin on silicon devices containing the thin film structure with very encouraging results.

1997 – Participation in the workshop – held in Asti – on hydrogen behaviour anomalies in metals.

1998 – Participation in the Vancouver ICCF7 and presentation of the results of the above-mentioned experimentation.

2000 - Participation in the Lericci ICCF8 where a possible evolution of the experimental results previously achieved in an “energy amplifier” is reported. Actually the attempts to exceed the results achieved in 1996 did turn out to be uncertain, even if the general concept exposed through the idea of the amplifier is still valid.

2004 – Beginning from 2000, at first there is the attempt to exceed the experimental results of 1996 in order to equip the energy amplifier with a Cold Fusion "reactor". Due to the difficulties met, some theoretical aspects relating to the activity by other researchers, even of the past, are examined in depth to try to understand which circumstances and physics are involved in such anomalies. Attempts are made to reproduce the experimental results achieved by the physician don Carlo Borghi (1910-1984) at Recife in Brazil on neutrons generated by a cold hydrogen plasma. The ICCF11 is held in Marseille where the activities carried out with the University of Lecce on the effects of transmutation in thin laser-excited palladium films is reported.

2007 – From 2004 until today, in-depth studies on the role of thin film structures or in the shape of nanoparticles for the setting-up of little cold fusion reactors are carried on. Collaboration between the University of Lecce (Prof. Nassisi) and Frascati INFN (group headed by Dr. Celani) interesting transmutation effects and heat excess events are attained making hope for rapid progress in the practical exploitation of the phenomena associated with or derived from the so-called Cold Fusion.

The pages hereinafter reproduce:

1. The abstract of the article "Energy amplifier device";
2. The article "Modification of pd-H₂ and Pd-D₂ thin films processed by He-Ne laser";
3. The abstract of the publication "Very thin nickel layers heated over Curie temperature show high temperature spots in hydrogen loading experiments"; and,
4. The abstract of a note by Prof. don Carlo Borghi (1910-1984), "The stationary states of the proton-electron system in a non-Euclidean continuum", repropoed by U. Mastromatteo

1

AN ENERGY AMPLIFIER DEVICE

UBALDO MASTROMATTEO
STMicroelectronics - Milan

Abstract¹

After more than ten years from the beginning of the experiments, in laboratories of many countries, aimed to confirm the phenomenology claimed by Fleischmann and Pons in March 1989, in which the lattice of hydrogen-loaded metals nuclear reactions can take place at temperatures not above a few hundreds degrees centigrade; the scientific certainty of this possibility has been achieved.

Actually, the work of cold fusion experimenters is now mainly devoted to finding the best technological approach to activate these phenomena in a reproducible, efficient, clean way. A more attractive approach uses a simple nickel layer at high temperature in a hydrogen environment.

Many experiments using this kind of approach demonstrated a very interesting correlation between excess heat coming from hydrogen-loaded nickel and electrical, thermodynamic conditions of the system.

Using a peculiar system configuration devoted to the qualitative study of these phenomena, in recent experiments it was possible to evaluate approximately the average micro-system amplification. Moreover, in the spots where excess energy melted the material, the amplification was estimated to be larger than 10.

Under way is an effort to change the system to control, with a suitable feedback block, the local amplification values, in order to extend them in a stable way to the main part of the active material.

A general partitioning of the Energy Amplifier System is showed in figure 1.

¹ Paper contributed to ICCF8 (Lerici, Italy 2000) and published in Conference Proceedings SIF Vol. 70 (2000)

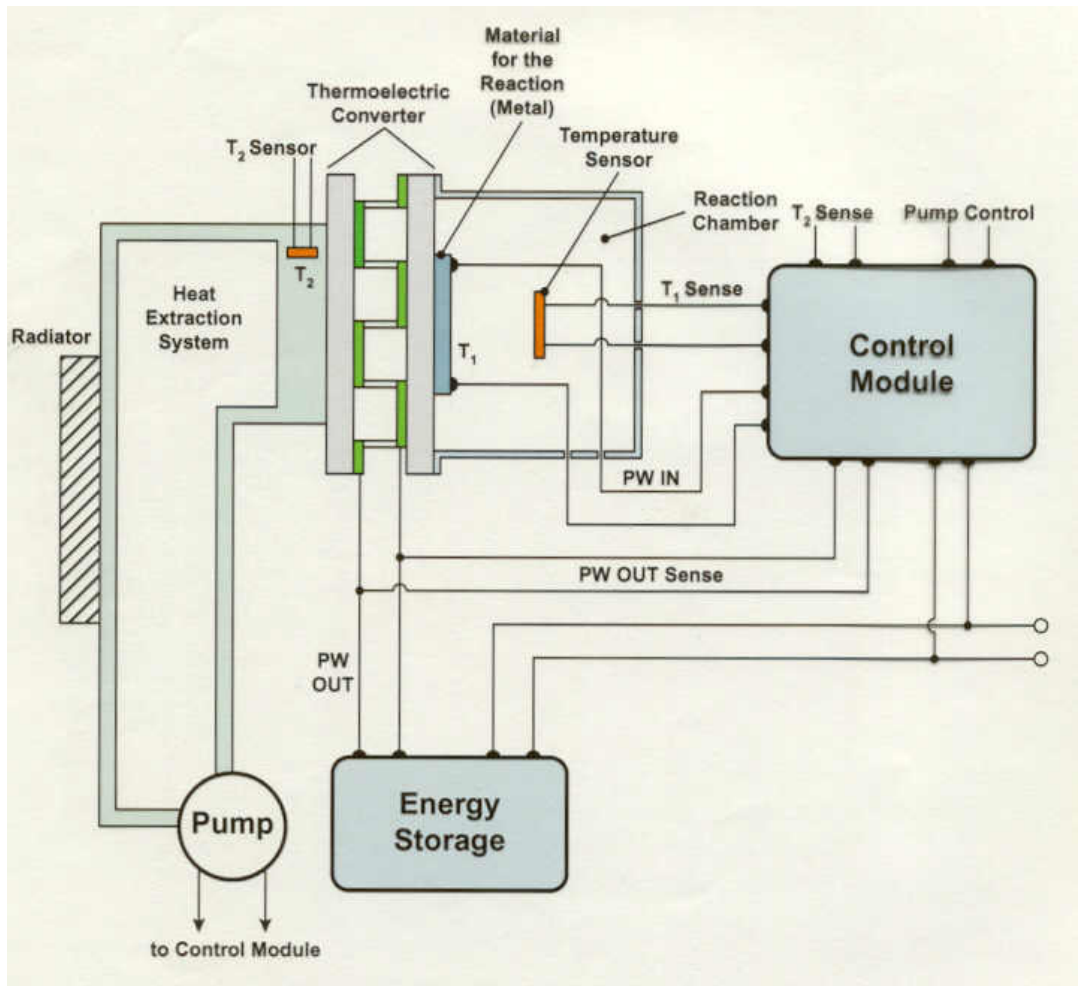

Fig. 1 - The energy amplifier & other control modules

MODIFICATION OF Pd-H₂ AND Pd-D₂ THIN FILMS PROCESSED BY HE-NE LASER

VINCENZO NASSISI, GIUSEPPE CARETTO, ANTONELLA LORUSSO

*Laboratory of Applied Electronics, Department of Physics, INFN,
University of Lecce, Lecce-I*

**DANIELA MANNO, LIA FAMÀ, GIOVANNI BUCCOLIERI,
ALESSANDRO BUCCOLIERI**

Department of Material Science, University of Lecce, Lecce-I

UBALDO MASTROMATTEO

STMicronics - Milan

Abstract

In this work we have performed experiments of absorption of hydrogen and deuterium gas by Pd thin films and we have studied the behavior of these samples compared with non processed ones. We have also employed, during the treatment, a continuous wave He-Ne laser to irradiate the samples inside the chamber in order to increase the gas absorption. By a scanning electron microscope (SEM) and an electron probe micro analyzer (EDX) we have observed, on the surface of the treated samples, the presence of structures like spots and inside them different elements from Pd were found. By these results we can say that the gas loading has been a very important condition to produce “transmutation” elements and the laser action has been very interesting in order to increase the morphological modifications of the treated samples.

Introduction

In March 1989 M. Fleischmann and S. Pons [1] reported that a great excess of enthalpy, recorded with a weak amount of radioactivity, had been detected in electrolytic cells with Palladium (Pd) cathodes during the electrolysis of D₂O, achieving a critical threshold of the stoichiometric ratio $x=[D]/[Pd]$ of Deuterium in Pd. The main point at issue was that the claimed excesses of enthalpy were consistent only with a nuclear process (fusion of Deuterons) and that such a process at ambient temperature and without the emission of a adequate number of neutrons was considered to be inconsistent with modern nuclear science.

In the following years many works about the production of excess heat and Helium have been published [2, 3], and many devices to improve the stoichiometric ratio x have been studied [4]. Possible theoretical explanations of the reported phenomena were proposed [5, 6] during these years but we are far to justify completely all obtained results jet.

Recently the gas loading method became a very interesting tool to obtain adequate absorption of D or H gases inside Pd metallic lattice accompanied with the possibility to keep low the contamination grade during the experiment [7]. Important results were achieved by this method and particular attention was made to reproduce transmutation effects [8].

In this work our attention is voted to study the transmutation phenomenon utilizing Pd film samples treated by gas loading. We have also implanted B in these samples in order to try to have control of the eventually nuclear processes such as Iwamura et al. have done. The treatment of the samples was combined with a continuous wave He-Ne laser light in order to improve the gas loading inside Pd thin films as in previous works was studied [9].

Experimental set-up and results

We have realized, by thermal evaporation technique, Pd thin films of 500 nm of thickness deposited on Si wafers of about 1 cm^2 in surface. A 50 nm Ti layer was used to improve the adhesion between the substrate and the Pd layer. These samples were implanted with B ions; a 150 keV accelerating voltage allowed to reach the maximum ion concentration at 158 nm depth in the palladium layer.

Fig. 1 shows the distribution of B ions versus target depth.

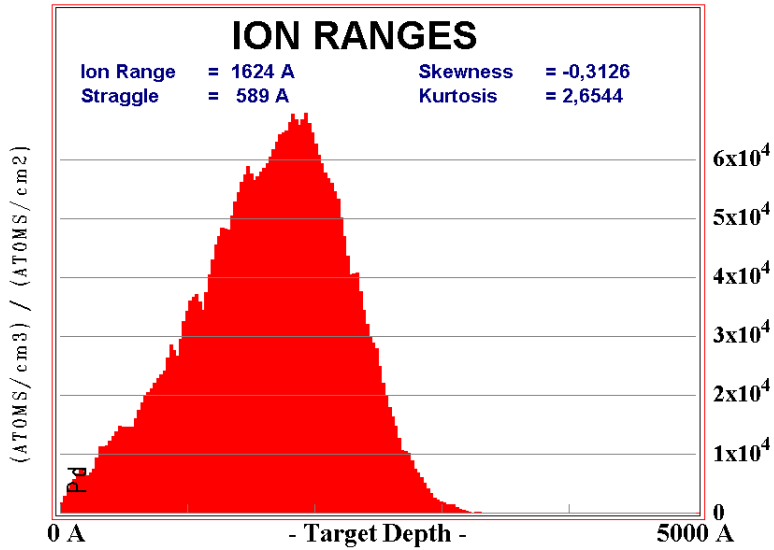

Fig. 1 - Boron ions distributions vs. target depth

They were placed in cylindrical stainless steel chambers of about 250 cm³ in volume. Fig. 2 shows a photo of the experimental set-up.



Fig. 2 - Photo of experimental set-up

The chambers were equipped at least of a quartz window in order to allow the laser beam to go until the samples. To avoid contaminations, the chambers were carefully cleaned with acetone and dried in nitrogen flux before the experiment beginning. Subsequently a pair of Pd/Si samples has been placed inside the chambers filled with H₂ or D₂ gas to a maximum pressure of 4 bar. In Fig. 3 we have a schematic drawing of a chamber.

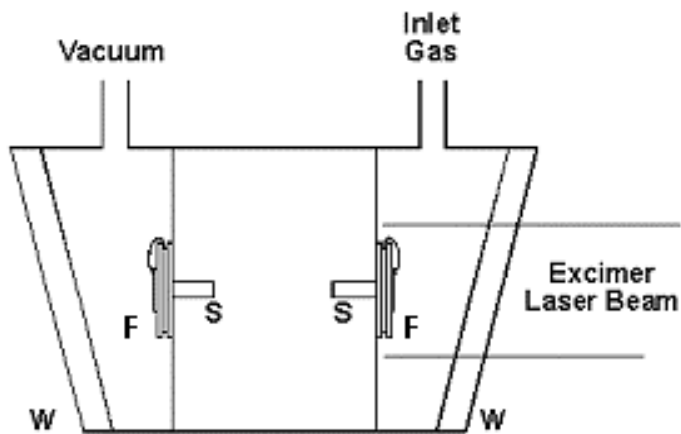

Fig. 3 - Schematic drawing of a chamber. W: quartz windows; S: supports where the samples are fixed; F: film samples

The treatment of the samples was employed with gas loading and only one sample for each chamber was irradiated by a cw He-Ne laser ($\lambda=648$ nm) from July 16th to September 29th 2004 at a laser power density of about 2 mW/cm².

After the treatment ending, the samples were analysed by a Scanning Electron Microscope (SEM) and an EDX micro-analyser. Different behaviours were revealed for samples kept in air, laser treated and no-laser treated: so, about the samples kept in air, the film surface was smooth, it looked like a mirror; instead, the samples treated and no-treated by laser showed morphological modifications of the Pd-film due to the gas absorption. The morphological modifications consisted in formation of spots with dimension of 1-50 μm after gas loading. Fig. 4 shows an example of spots on the surface of a sample of palladium implanted with boron, loaded by D₂ gas and not irradiated.

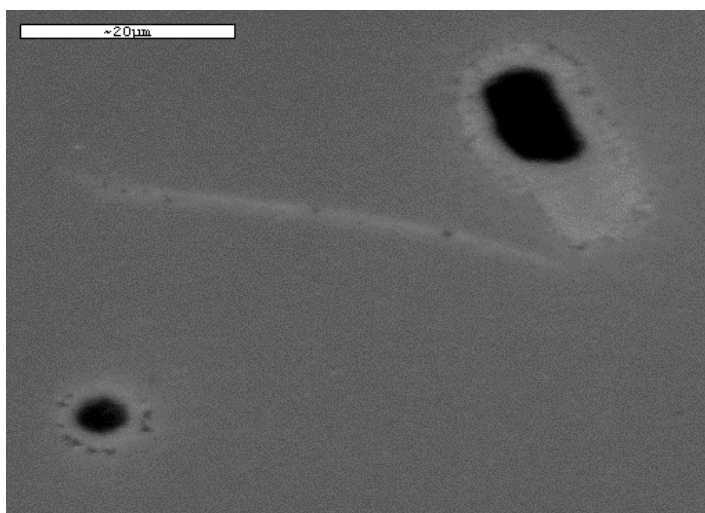

Fig. 4 - Spots on the surface of a sample with 76 days of treatment (by D₂ gas only)

By EDX analyser, we have investigated inside the spots and we have found the presence of new elements such as C, O, Ca, Fe, Al, S, Mg, K and Na. In Fig. 5 an example of EDX spectrum of a Pd sample with 76 days of treatment is reported. It is possible to observe the presence of many “new” elements which were inexistent before the treatment.

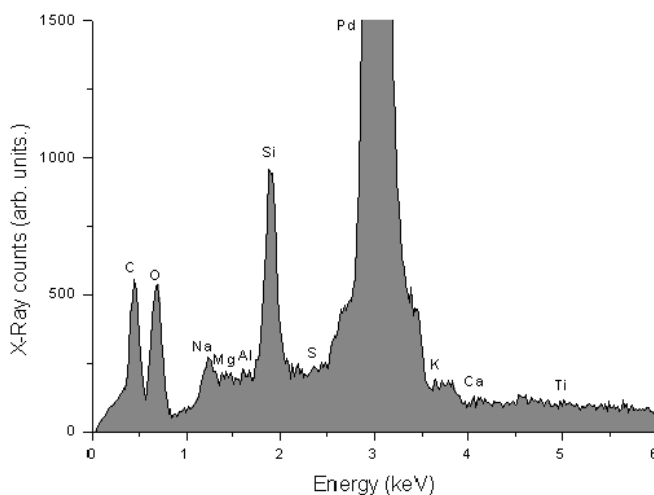

Fig. 5 - EDX spectrum of a sample with 76 days of treatment (by D₂ gas only).
We can observe the presence of the following elements:
C, O, Ca, Al, S, Mg, K, Na

In addition, by He-Ne laser action, we have found a larger number of spots and a larger number of new elements. Fig. 6 shows a SEM micrograph of a sample processed by H₂ gas and laser; Fig. 7 shows EDX spectrum obtained from one spots of the sample: the new elements were: C, O, Ca, Fe, Al, S, Mg, K, Na, F, Cr, Mn, Fe, Co, Ni.

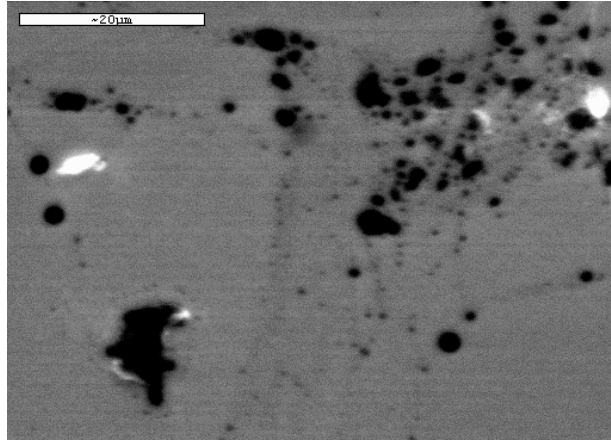

Fig. 6 - Spots on the surface of a sample with 76 days of treatment by H₂ gas and by He-Ne laser action)

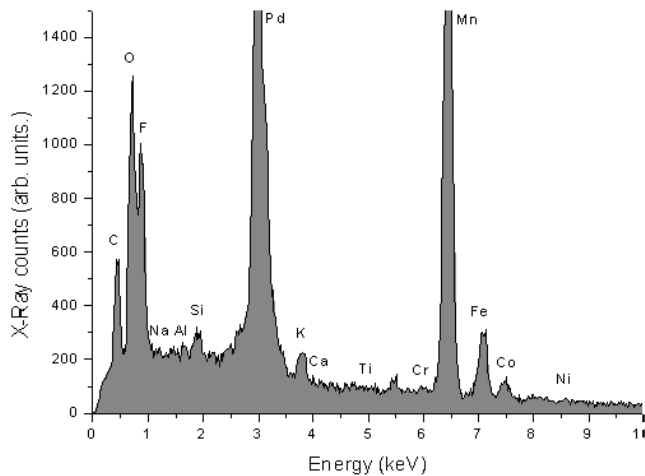

Fig. 7 - EDX spectrum of a sample with 76 days of treatment (by H₂ gas and He-Ne laser). We can observe the presence of the following elements: C, O, Ca, Fe, Al, S, Mg, K, Na, F, Cr, Mn, Co, Ni

In Tab.1 the list of the new elements is reported for every experimental case of the sample treatment. We can observe that the combination between H₂ gas loading and laser action on the treatment of the samples is very interesting in order to produce many transmutation elements; nevertheless the results with D₂ gas loading are also not negligible about the production of new elements, but there are no evident differences between laser and no laser treated samples. The laser action is also very important to increase the spot density on the surface of the treated samples. All new elements were found inside the spots systematically but none of these seems to be generated from a particular nuclear reaction between B and D₂ and H₂. These experiments confirm the reproducibility of the transmutation phenomenon but we are still far to make clarifications about the mechanisms which happened inside the crystalline lattice of Pd samples.

H ₂		D ₂	
Laser	No-laser	Laser	No-laser
Si	Si	Si	Si
Pd	Pd	Pd	Pd
Ti	Ti	Ti	Ti
C		C	C
O		O	O
Ca		Ca	Ca
K		K	K
Na		Na	Na
Al		Al	Al
Cr		Mg	Mg
Fe			S
Co			
Ni			
Mn			
S			
F			

Tab. 1 - The main detected elements in every experimental case

References

- [1] M. FLEISCHMANN, S.J. PONS, *J. of Electroanal. Chem.* **261**, 301 (1989).
- [2] A. B. KARABUT, ICCF9, Beijing, China, May 19-24, 151 (2002)
- [3] F. CELANI, A. SPALLONE, P. TRIPODI, A. PETROCCHI, D. DI GIOACCHINO, P. MARINI, V. DI STEFANO, S. PACE, A. MANCINI, *Phys. Lett. A* **214**, 1 (1996)
- [4] A. DE NINNO, A. LA BARBERA, V. VIOLANTE, *Phys. Rev. B* **56**, 2417 (1997).
- [5] M. FLEISCHMANN, S. PONS, G. PREPARATA, *Nuovo Cimento* **105A**, 763 (1992).
- [6] A. TAKAHASHI, ICCF9, Beijing, China, May 19-24, 343 (2002).
- [7] F. SCARAMUZZI, *Survey of Gas Loading Experiments, in Second Annual Conference on Cold Fusion*, "The Science of Cold Fusion", Como, Italy (1991).
- [8] Y. IWAMURA, T. ITOH, M. SAKANO, S. SAKAI AND S. KURIBAYASHI, ICCF-10, Cambridge, MA, Aug 24-29, 68 (2003).
- [9] V. NASSISI, *Fusion Technol.* **33**, 468 (1998).

VERY THIN NICKEL LAYERS HEATED OVER CURIE TEMPERATURE SHOW HIGH TEMPERATURE SPOTS IN HYDROGEN LOADING EXPERIMENTS

UBALDO MASTROMATTEO
STMicroelectronics – Milan

Abstract²

With the purpose to study the behavior of thin Nickel layers in presence of hydrogen, a prototype microcell has been designed using a silicon chip of about 6 mm² size. On one side of the chip it has been realized a structure including a low electrical resistance polysilicon heater (anode), a high Hydrogen content dielectric layer and a 0.1 mm thick Nickel resistor (cathode).

Several experiments using that cell prototype have pointed out that it is possible in certain conditions of temperature and electrical biasing, the activation into the metallic lattice of Hydrogen absorption able to modify the electrical resistivity of the layer and also generating large fusion spots in the Nickel layer due to high and fast temperature rising. This high temperature is not explained by chemical exothermic reactions or by external power input instability.

If those should be led, as calculation about specific power needed to have such fusion spots say, to *cold fusion phenomena*, then a different configuration of the cell, more suitable for heat extraction and robustness of Nickel layer should be easy to prepare for excess power measurements and quantification.

We are actually working on the design of a new cell configuration with a completely integrate calorimeter (microbolometer) able to detect any small temperature increase (even locally) through thermal emissions measurements. This control system may be in the same cell environment and electrically connected to the input power control system to guarantee maximum system stability. The actual cell dimensions are in the range of a small integrate silicon chip, because the purpose of the experiments is to realize a power generation device suitable for portable electric apparatus, but it is in principle completely scalable for high power generation.

² Paper contributed to the 3rd Asti Workshop and published in Conference Proceedings SIF Vol. 64 (1999)

THE STATIONARY STATES OF THE PROTON-ELECTRON SYSTEM IN A NON-EUCLIDEAN CONTINUUM

CARLO BORGHI
University of Milan

Reproposed by **UBALDO MASTROMATTEO**
STMicroelectronics - Milan

Abstract

Once establishing the transformations of the Schrödinger equation into a locally non-euclidean continuum, they are evidenced to be the source of the existence of a hydrogen atom barrier. Moreover, the existence of stationary states of the electron within such barrier is shown along with the characteristic transformations that these particular conditions bring about both in the electron and in the inner electron-proton system.

Comment for the readers

The original note consists in a 15-page typed document (with hand-added formulas) where, during its transcription, a pair of inaccuracies in the original formulas has been corrected (essentially the lack of minus signs at the exponent), yet without affecting the development of the following passages. This is a clear evidence that the original text as well is the outcome of a very detailed process full of intermediate passages we have no longer trace of, but which underwent a very careful check by don Borghi himself. The original document is dated December 1942, when don Borghi was Professor of Theoretical Physics and Statistics at the University of Milan.

The original approach is not only interesting in itself, but it is also very topical for the possible explanations of nuclear anomalies for which the formation of neutral particles from hydrogen isotopes can be hypothesized. The treatment derives their existence by using mathematical instruments, still valid today, with rigour. Furthermore, we consider the hypothesis of the non-Euclidicity of space quite agreeable if we accept the Theory of General Relativity as valid.

6.4. Cold Fusion at ORIM SpA

ALFREDO MANCINI
ORIM SpA - Macerata

Since its establishment in 1982, Orim SpA specialized in the recovery of precious metals and their subsequent processing.

All recovery activities are exclusively carried out on waste containing such metals, by using chemical and/or electrochemical technologies.

Examples of such activity are Ag recovery from the cine-photo-radiographic sector or from electromechanical components, Pd recovery from chemical industry catalysts, from dental prostheses elements and/or orthodontic production waste, and Au recovery from electronic scrap.

In 1992, after reading an article on the daily paper “Sole 24 ore” on Dr. Francesco Celani’s Cold Fusion research at INFN Frascati, the Managing Director found out that the Pd wires used for such research were bought in Japan.

Being the Managing Director an electro-chemical engineer, this information drew his attention strongly. In addition, at that time ORIM did produce precious-metal wires and tubes.

Therefore he decided to contact directly INFN to supply for free semi-finished products for testing.

The collaboration began after Dr. Celani had visited the company, where he could verify the quality of both wire- and weldless tube-casting, manufactured with pure precious metals and/or their alloys.

The first free supplies of semi-finished products, especially Pd 999.8 wires, produced exciting results both for the repeatability of experiments and the high H₂ hyperloading into palladium.

Following these results, several multiyear research contracts were signed both with INFN and with INFN.

Since those early supplies, the collaboration has been broadened by providing technical, analytical and/or documental support.

Confirming the fact that waste management benefits the Environment, Economy and Research, it is important to point out and reassert once

again that the semi-finished products initially delivered were coming from metal reclamation from waste.

Such support to the INFN research gave ORIM and its Managing Director, Alfredo Mancini, the opportunity to be mentioned, although for little contributions, among the authors of innumerable works and/or abstracts published by Dr. Francesco Celani during all these years.

Besides this research ORIM extended its collaboration also to other activities.

In the wake of success by Dr. Yasuhiro Iwamura at Mitsubishi – concerning the apparent “transmutation” of natural Strontium and Caesium, opportunely deposited on a Palladium substrate in a particular Deuterium-gas-fed “reactor” – in due time, ORIM asked to join – as a company with specific know-how in the treatment-purification of Palladium and its alloys – the Italian-Japanese research group engaged in exploring the possibility of extending the above transmutation phenomena even to Strontium and Caesium radioactive isotopes.

The project was named “*Scorie Zero*” – “*zero waste*”.

The Italian research group is lead by Dr. Francesco Celani.

ORIM, a medium-sized enterprise, is an advanced group targeting new technical-scientific developments.

ORIM’s main target is the recovery or disposal of any kind of waste coming from industrial activities, even through innovative technology. The more difficult the waste problem is, the higher is the interest to invest in it.

Following the same logics, nuclear waste is considered equivalent to waste coming from nuclear activities, thus interesting for Orim.

ORIM believes strongly in the working enthusiasm of Dr. Francesco Celani and his team, using high technical-scientific skills in the experiments performed. Moreover, on several occasions Orim pointed out chances of innovation by planning and executing complex and delicate experiments with the INFN team.

At the moment, the company efforts are aimed at recovering strategic metals (Mo, V, Co, Ni) present in spent catalysts from chemical and petrochemical industry. In such studies the Company is supported by the Faculty of Chemical Engineering from the University of L’Aquila.

7. LIST OF CONTRIBUTING AUTHORS

	Page
A	
Abdel Harith Mohamed	107
B	
Baldo Marcello	141
Bertalot Luciano	105, 106
Boragno Corrado	137
Borghi Carlo	212
Buccolieri Alessandro	203
Buccolieri Giovanni	203
C	
Caputo Riccardina	183
Caretto Giuseppe	203
Celani Francesco	115
Cellucci Fabio	183
Cignini Pierluigi	183
Cisbani Evaristo	183
D	
Daddi Lino	193
De Marco Francesco	105, 111
Del Giudice Emilio	81, 165
De Ninno Antonella	73, 105, 106
E	
Eggenhoffner Roberto	137
F	
Famà Lia	203
Felici Roberto	105, 106
Focardi Sergio	171
Fontana Flavio	197
Frattolillo Antonio	73
Frisone Fulvio	143
Frullani Salvatore	183

G

Gamberale Luca	197
Garbelli Daniele	197
Garibaldi Franco	183
Gigli Guido	183
Gozzi Daniele	183

L

La Barbera Aurelio	67, 105, 106
Lorusso Antonella	155, 203

M

Mancini Alfredo	213
Manno Daniela	203
Martellucci Sergio	V, 1, 11, 47, 103, 107, 109, 163, 195
Mastromatteo Ubaldo	199, 201, 203, 211, 212

N

Nassisi Vincenzo	155, 203
------------------	----------

P

Paganetto Luigi	VII
Pal Singh Darm	107
Palleschi Vincenzo	107
Piantelli Francesco	171
Prati Paolo	137

R

Ricci Renato Angelo	111
Ricco Giovanni	137
Rosati Angela	V

S

Salvetti Giuseppe	107
Scalia Augusto	147
Scaramuzzi Francesco	V, 13, 21, 51, 76, 99, 105
Sindoni Elio	111

T

Taiuti Mauro	137
Tomellini Massimo	183

U

Urciuoli Guido Maria	183
----------------------	-----

V

Valbusa Ugo	137
Vaselli Moreno	107
Violante Vittorio	V, 87, 105, 106, 198

Published by ENEA

Communication Unit

Lungotevere Thaon di Revel, 76 – 00196 Roma

www.enea.it

Editing: Giuliano Ghisu

Cover design: Bruno Giovannetti, Cristina Lanari

Printed in March 2009 at Frascati Research Centre